

Innova™ IGS 6

Pre-Installation Manual



5750182-1EN

3

© 2017 General Electric Company
All rights reserved.

Language policy

Direction 2128126 - Language Policy For Service Documentation

<p>ПРЕДУПРЕЖДЕНИЕ (BG)</p>	<p>Това упътване за работа е налично само на английски език.</p> <ul style="list-style-type: none"> Ако доставчикът на услугата на клиента изиска друг език, задължение на клиента е да осигури превод. Не използвайте оборудването, преди да сте се консултирали и разбрали упътването за работа. Неспазването на това предупреждение може да доведе до нараняване на доставчика на услугата, оператора или пациента в резултат на токов удар, механична или друга опасност.
<p>警告 (ZH-CN)</p>	<p>本维修手册仅提供英文版本。</p> <ul style="list-style-type: none"> 如果客户的维修服务人员需要非英文版本，则客户需自行提供翻译服务。 未详细阅读和完全理解本维修手册之前，不得进行维修。 忽略本警告可能对维修服务人员、操作人员或患者造成电击、机械伤害或其他形式的伤害。
<p>警告 (ZH-HK)</p>	<p>本服務手冊僅提供英文版本。</p> <ul style="list-style-type: none"> 倘若客戶的服務供應商需要英文以外之服務手冊，客戶有責任提供翻譯服務。 除非已參閱本服務手冊及明白其內容，否則切勿嘗試維修設備。 不遵從本警告或會令服務供應商、網絡供應商或病人受到觸電、機械性或其他形式的危險。
<p>警告 (ZH-TW)</p>	<p>本維修手冊僅有英文版。</p> <ul style="list-style-type: none"> 若客戶的維修廠商需要英文版以外的語言，應由客戶自行提供翻譯服務。 請勿試圖維修本設備，除非您已查閱並瞭解本維修手冊。 若未留意本警告，可能導致維修廠商、操作員或病患因觸電、機械或其他危險而受傷。
<p>UPOZOR- ENJE (HR)</p>	<p>Ovaj servisni priručnik dostupan je na engleskom jeziku.</p> <ul style="list-style-type: none"> Ako davatelj usluge klijenta treba neki drugi jezik, klijent je dužan osigurati prijevod. Ne pokušavajte servisirati opremu ako niste u potpunosti pročitali i razumjeli ovaj servisni priručnik. Zanemarite li ovo upozorenje, može doći do ozljede davatelja usluge, operatera ili pacijenta uslijed strujnog udara, mehaničkih ili drugih rizika.
<p>VÝSTRAHA (CS)</p>	<p>Tento provozní návod existuje pouze v anglickém jazyce.</p> <ul style="list-style-type: none"> V případě, že externí služba zákazníkům potřebuje návod v jiném jazyce, je zajištění překladu do odpovídajícího jazyka úkolem zákazníka. Nesnažte se o údržbu tohoto zařízení, aniž byste si přečetli tento provozní návod a pochopili jeho obsah. V případě nedodržování této výstrahy může dojít k poranění pracovníka prodejního servisu, obslužného personálu nebo pacientů vlivem elektrického proudu, respektive vlivem mechanických či jiných rizik.

ADVARSEL (DA)	<p>Denne servicemanual findes kun på engelsk.</p> <ul style="list-style-type: none"> • Hvis en kundes tekniker har brug for et andet sprog end engelsk, er det kundens ansvar at sørge for oversættelse. • Forsøg ikke at servicere udstyret uden at læse og forstå denne servicemanual. • Manglende overholdelse af denne advarsel kan medføre skade på grund af elektrisk stød, mekanisk eller anden fare for teknikeren, operatøren eller patienten.
WAAR-SCHUWING (NL)	<p>Deze onderhoudshandleiding is enkel in het Engels verkrijgbaar.</p> <ul style="list-style-type: none"> • Als het onderhoudspersoneel een andere taal vereist, dan is de klant verantwoordelijk voor de vertaling ervan. • Probeer de apparatuur niet te onderhouden alvorens deze onderhoudshandleiding werd geraadpleegd en begrepen is. • Indien deze waarschuwing niet wordt opgevolgd, zou het onderhoudspersoneel, de operator of een patiënt gewond kunnen raken als gevolg van een elektrische schok, mechanische of andere gevaren.
WARNING (EN)	<p>This service manual is available in English only.</p> <ul style="list-style-type: none"> • If a customer's service provider requires a language other than English, it is the customer's responsibility to provide translation services. • Do not attempt to service the equipment unless this service manual has been consulted and is understood. • Failure to heed this warning may result in injury to the service provider, operator or patient from electric shock, mechanical or other hazards.
HOIATUS (ET)	<p>See teenindusjuhend on saadaval ainult inglise keeles.</p> <ul style="list-style-type: none"> • Kui klienditeeninduse osutaja nõuab juhendit inglise keelest erinevas keeles, vastutab klient tõlketeenuse osutamise eest. • Ärge üritage seadmeid teenindada enne eelnevalt käesoleva teenindusjuhendiga tutvumist ja sellest aru saamist. • Käesoleva hoiatuse eiramine võib põhjustada teenuseosutaja, operaatori või patsiendi vigastamist elektrilöögi, mehaanilise või muu ohu tagajärjel.
VAROITUS (FI)	<p>Tämä huolto-ohje on saatavilla vain englanniksi.</p> <ul style="list-style-type: none"> • Jos asiakkaan huoltohenkilöstö vaatii muuta kuin englanninkielistä materiaalia, tarvittavan käännöksen hankkiminen on asiakkaan vastuulla. • Älä yritä korjata laitteistoa ennen kuin olet varmasti lukenut ja ymmärtänyt tämän huolto-ohjeen. • Mikäli tätä varoitusta ei noudateta, seurauksena voi olla huoltohenkilöstön, laitteiston käyttäjän tai potilaan vahingoittuminen sähköiskun, mekaanisen vian tai muun vaaratilanteen vuoksi.

ATTENTION (FR)	<p>Ce manuel d'installation et de maintenance est disponible uniquement en anglais.</p> <ul style="list-style-type: none"> • Si le technicien d'un client a besoin de ce manuel dans une langue autre que l'anglais, il incombe au client de le faire traduire. • Ne pas tenter d'intervenir sur les équipements tant que ce manuel d'installation et de maintenance n'a pas été consulté et compris. • Le non-respect de cet avertissement peut entraîner chez le technicien, l'opérateur ou le patient des blessures dues à des dangers électriques, mécaniques ou autres.
WARNUNG (DE)	<p>Diese Serviceanleitung existiert nur in englischer Sprache.</p> <ul style="list-style-type: none"> • Falls ein fremder Kundendienst eine andere Sprache benötigt, ist es Aufgabe des Kunden für eine entsprechende Übersetzung zu sorgen. • Versuchen Sie nicht diese Anlage zu warten, ohne diese Serviceanleitung gelesen und verstanden zu haben. • Wird diese Warnung nicht beachtet, so kann es zu Verletzungen des Kundendiensttechnikers, des Bedieners oder des Patienten durch Stromschläge, mechanische oder sonstige Gefahren kommen.
ΠΡΟΕΙΔΟΠΟΙΗΣΗ (EL)	<p>Το παρόν εγχειρίδιο σέρβις διατίθεται στα αγγλικά μόνο.</p> <ul style="list-style-type: none"> • Εάν το άτομο παροχής σέρβις ενός πελάτη απαιτεί το παρόν εγχειρίδιο σε γλώσσα εκτός των αγγλικών, αποτελεί ευθύνη του πελάτη να παρέχει υπηρεσίες μετάφρασης. • Μηνεπιχειρήσετε την εκτέλεση εργασιών σέρβις στον εξοπλισμό εκτός εάν έχετε συμβουλευτεί και έχετε κατανοήσει το παρόν εγχειρίδιο σέρβις. • Εάν δεν λάβετε υπόψη την προειδοποίηση αυτή, ενδέχεται να προκληθεί τραυματισμός στο άτομο παροχής σέρβις, στο χειριστή ή στον ασθενή από ηλεκτροπληξία, μηχανικούς ή άλλους κινδύνους.
FIGYELMEZTETÉS (HU)	<p>Ezen karbantartási kézikönyv kizárólag angol nyelven érhető el.</p> <ul style="list-style-type: none"> • Ha a vevő szolgáltatója angoltól eltérő nyelvre tart igényt, akkor a vevő felelőssége a fordítás elkészíttetése. • Ne próbálja elkezdni használni a berendezést, amíg a karbantartási kézikönyvben leírtakat nem értelmezték. • Ezen figyelmeztetés figyelmen kívül hagyása a szolgáltató, működtető vagy a beteg áramütés, mechanikai vagy egyéb veszélyhelyzet miatti sérülését eredményezheti.
AÐVÖRUN (IS)	<p>Þessi þjónustuhandbók er aðeins fáanleg á ensku.</p> <ul style="list-style-type: none"> • Ef að þjónustuveitandi viðskiptamanns þarfnast annars tungumáls en ensku, er það skylda viðskiptamanns að skaffa tungumálþjónustu. • Reynið ekki að afgreiða tækið nema að þessi þjónustuhandbók hefur verið skoðuð og skilin. • Brot á sinna þessari aðvörun getur leitt til meiðsla á þjónustuveitanda, stjórnanda eða sjúklings frá raflosti, vélrænu eða öðrum áhættum.

AVVERTENZA (IT)	<p>Il presente manuale di manutenzione è disponibile soltanto in lingua inglese.</p> <ul style="list-style-type: none"> • Se un addetto alla manutenzione richiede il manuale in una lingua diversa, il cliente è tenuto a provvedere direttamente alla traduzione. • Procedere alla manutenzione dell'apparecchiatura solo dopo aver consultato il presente manuale ed averne compreso il contenuto. • Il mancato rispetto della presente avvertenza potrebbe causare lesioni all'addetto alla manutenzione, all'operatore o ai pazienti provocate da scosse elettriche, urti meccanici o altri rischi.
警告 (JA)	<p>このサービスマニュアルには英語版しかありません。</p> <ul style="list-style-type: none"> • サービスを担当される業者が英語以外の言語を要求される場合、翻訳作業はその業者の責任で行うものとさせていただきます。 • このサービスマニュアルを熟読し理解せずに、装置のサービスを行わないでください。 • この警告に従わない場合、サービスを担当される方、操作員あるいは患者さんが、感電や機械的又はその他の危険により負傷する可能性があります。
경고 (KO)	<p>본 서비스 매뉴얼은 영어로만 이용하실 수 있습니다.</p> <ul style="list-style-type: none"> • 고객의 서비스 제공자가 영어 이외의 언어를 요구할 경우, 번역 서비스를 제공하는 것은 고객의 책임입니다. • 본 서비스 매뉴얼을 참조하여 숙지하지 않은 이상 해당 장비를 수리하려고 시도하지 마십시오. • 본 경고 사항에 유의하지 않으면 전기 쇼크, 기계적 위험, 또는 기타 위험으로 인해 서비스 제공자, 사용자 또는 환자에게 부상을 입힐 수 있습니다.
BRĪDINĀ- JUMS (LV)	<p>Šī apkopes rokasgrāmata ir pieejama tikai angļu valodā.</p> <ul style="list-style-type: none"> • Ja klienta apkopes sniedzējam nepieciešama informācija citā valodā, klienta pienākums ir nodrošināt tulkojumu. • Neveiciet aprikojuma apkopi bez apkopes rokasgrāmatas izlasīšanas un saprašanas. • Šī brīdinājuma neievērošanas rezultātā var rasties elektriskās strāvas triecienu, mehānisku vai citu faktoru izraisītu traumu risks apkopes sniedzējam, operatoram vai pacientam.
ĮSPĖJIMAS (LT)	<p>Šis eksploataavimo vadovas yra tik anglų kalba.</p> <ul style="list-style-type: none"> • Jei kliento paslaugų tiekėjas reikalauja vadovo kita kalba – ne anglų, suteikti vertimo paslaugas privalo klientas. • Nemėginkite atlikti įrangos techninės priežiūros, jei neperskaitėte ar nesupratote šio eksploataavimo vadovo. • Jei nepaisysite šio įspėjimo, galimi paslaugų tiekėjo, operatoriaus ar paciento sužalojimai dėl elektros šoko, mechaninių ar kitų pavojų.
ADVARSEL (NO)	<p>Denne servicehåndboken finnes bare på engelsk.</p> <ul style="list-style-type: none"> • Hvis kundens serviceleverandør har bruk for et annet språk, er det kundens ansvar å sørge for oversettelse. • Ikke forsøk å reparere utstyret uten at denne servicehåndboken er lest og forstått. • Manglende hensyn til denne advarselen kan føre til at serviceleverandøren, operatøren eller pasienten skades på grunn av elektrisk støt, mekaniske eller andre farer.

<p>OSTRZEŻENIE (PL)</p>	<p>Niniejszy podręcznik serwisowy dostępny jest jedynie w języku angielskim.</p> <ul style="list-style-type: none"> • Jeśli serwisant klienta wymaga języka innego niż angielski, zapewnienie usługi tłumaczenia jest obowiązkiem klienta. • Nie próbować serwisować urządzenia bez zapoznania się z niniejszym podręcznikiem serwisowym i zrozumienia go. • Niezastosowanie się do tego ostrzeżenia może doprowadzić do obrażeń serwisanta, operatora lub pacjenta w wyniku porażenia prądem elektrycznym, zagrożenia mechanicznego bądź innego.
<p>ATENÇÃO (PT-BR)</p>	<p>Este manual de assistência técnica encontra-se disponível unicamente em inglês.</p> <ul style="list-style-type: none"> • Se outro serviço de assistência técnica solicitar a tradução deste manual, caberá ao cliente fornecer os serviços de tradução. • Não tente reparar o equipamento sem ter consultado e compreendido este manual de assistência técnica. • A não observância deste aviso pode ocasionar ferimentos no técnico, operador ou paciente decorrentes de choques elétricos, mecânicos ou outros.
<p>ATENÇÃO (PT-PT)</p>	<p>Este manual de assistência técnica só se encontra disponível em inglês.</p> <ul style="list-style-type: none"> • Se qualquer outro serviço de assistência técnica solicitar este manual noutra idioma, é da responsabilidade do cliente fornecer os serviços de tradução. • Não tente reparar o equipamento sem ter consultado e compreendido este manual de assistência técnica. • O não cumprimento deste aviso pode colocar em perigo a segurança do técnico, do operador ou do paciente devido a choques eléctricos, mecânicos ou outros.
<p>ATENȚIE (RO)</p>	<p>Acest manual de service este disponibil doar în limba engleză.</p> <ul style="list-style-type: none"> • Dacă un furnizor de servicii pentru clienți necesită o altă limbă decât cea engleză, este de datoria clientului să furnizeze o traducere. • Nu încercați să reparați echipamentul decât ulterior consultării și înțelegerii acestui manual de service. • Ignorarea acestui avertisment ar putea duce la rănirea depanatorului, operatorului sau pacientului în urma pericolelor de electrocutare, mecanice sau de altă natură.
<p>ОСТОРОЖНО! (RU)</p>	<p>Данное руководство по техническому обслуживанию представлено только на английском языке.</p> <ul style="list-style-type: none"> • Если сервисному персоналу клиента необходимо руководство не на английском, а на каком-то другом языке, клиенту следует самостоятельно обеспечить перевод. • Перед техническим обслуживанием оборудования обязательно обратитесь к данному руководству и поймите изложенные в нем сведения. • Несоблюдение требований данного предупреждения может привести к тому, что специалист по техобслуживанию, оператор или пациент получит удар электрическим током, механическую травму или другое повреждение.

UPOZOR- ENJE (SR)	<p>Ovo servisno uputstvo je dostupno samo na engleskom jeziku.</p> <ul style="list-style-type: none"> • Ako klijentov serviser zahteva neki drugi jezik, klijent je dužan da obezbedi prevodilačke usluge. • Ne pokušavajte da opravite uređaj ako niste pročitali i razumeli ovo servisno uputstvo. • Zanemarivanje ovog upozorenja može dovesti do povređivanja serviser, rukovaoca ili pacijenta usled strujnog udara ili mehaničkih i drugih opasnosti.
UPOZORNE- NIE (SK)	<p>Tento návod na obsluhu je k dispozícii len v angličtine.</p> <ul style="list-style-type: none"> • Ak zákazníkovi poskytovateľ služieb vyžaduje iný jazyk ako angličtinu, poskytnutie prekladateľských služieb je zodpovednosťou zákazníka. • Nepokúšajte sa o obsluhu zariadenia, kým si neprečítate návod na obsluhu a neporozumiete mu. • Zanedbanie tohto upozornenia môže spôsobiť zranenie poskytovateľa služieb, obsluhujúcej osoby alebo pacienta elektrickým prúdom, mechanické alebo iné ohrozenie.
ATENCION (ES)	<p>Este manual de servicio sólo existe en inglés.</p> <ul style="list-style-type: none"> • Si el encargado de mantenimiento de un cliente necesita un idioma que no sea el inglés, el cliente deberá encargarse de la traducción del manual. • No se deberá dar servicio técnico al equipo, sin haber consultado y comprendido este manual de servicio. • La no observancia del presente aviso puede dar lugar a que el proveedor de servicios, el operador o el paciente sufran lesiones provocadas por causas eléctricas, mecánicas o de otra naturaleza.
VARNING (SV)	<p>Den här servicehandboken finns bara tillgänglig på engelska.</p> <ul style="list-style-type: none"> • Om en kunds servicetekniker har behov av ett annat språk än engelska, ansvarar kunden för att tillhandahålla översättningstjänster. • Försök inte utföra service på utrustningen om du inte har läst och förstår den här servicehandboken. • Om du inte tar hänsyn till den här varningen kan det resultera i skador på serviceteknikern, operatören eller patienten till följd av elektriska stötar, mekaniska faror eller andra faror.
OPOZORILO (SL)	<p>Ta servisni priročnik je na voljo samo v angleškem jeziku.</p> <ul style="list-style-type: none"> • Če ponudnik storitve stranke potrebuje priročnik v drugem jeziku, mora stranka zagotoviti prevod. • Ne poskušajte servisirati opreme, če tega priročnika niste v celoti prebrali in razumeli. • Če tega opozorila ne upoštevate, se lahko zaradi električnega udara, mehanskih ali drugih nevarnosti poškoduje ponudnik storitev, operater ali bolnik.
DİKKAT (TR)	<p>Bu servis k&inodot;lavuzunun sadece ingilizcesi mevcuttur.</p> <ul style="list-style-type: none"> • Eğer müşteri teknisyeni bu k&inodot;lavuzu ingilizce d&inodot;ş&inodot;nda bir başka lisan-dan talep ederse, bunu tercüme ettirmek müşteriye düşer. • Servis k&inodot;lavuzunu okuyup anlamadan ekipmanlara müdahale etmeyiniz. • Bu uyar&inodot;ya uyulmamas&inodot;, elektrik, mekanik veya diğer tehlikelerden dolay&inodot; teknisyen, operatör veya hastan&inodot;n yaralanmas&inodot;na yol açabilir.

Revision History

Part/Rev	Date	Reason for Change	Pages
5750182-1EN rev 1	April 7, 2017	Initial release of 5750182-1EN	186
5750182-1EN rev 2	September 19, 2017	Release after HII review	192
5750182-1EN rev 3	November 6, 2017	Post FDR3 release	192

Page intentionally left blank

Contents

Chapter 1 General Requirements	1
1.1 Objectives & Overview	1
1.1.1 Object and Scope of this manual	1
1.1.2 Pre-Installation Process	1
1.2 Customer Responsibilities	2
1.2.1 Responsibilities of the Purchaser/Customer	2
1.2.2 Equipment Classifications	3
1.2.3 Pre-Installation Checklist	4
1.3 Delivery Requirements	5
1.3.1 Shipping Information	5
1.3.2 Tools and Test Equipment	19
1.3.3 Door Size Requirements	22
1.3.4 Route Survey	22
1.4 Product Storage and Handling Requirements	24
Chapter 2 Equipment Requirements	29
2.1 System Components	29
2.1.1 Presentation of the 3 Rooms	29
2.1.2 Description of the System	30
2.1.3 Dimension Drawings	37
2.1.4 Monitor and Monitor Suspension References	68
2.1.5 System Compatibility	69
2.2 Room Layouts	70
2.2.1 Room Dimension Requirements	70
2.2.2 Room Layout Drawings	70
2.2.3 Room Layout Considerations	78
2.3 Room Structural Requirements	84
2.3.1 Floor Requirements	84
2.3.2 Mounting Requirements	91
2.3.3 Ceiling Requirements	103
2.3.4 Wall Requirements	112
2.4 Seismic	113
Chapter 3 Special Construction Requirements	117
3.1 Radiation Protection	117
3.2 EMI Consideration	117
Chapter 4 Environmental Requirements	127
4.1 Relative Humidity and Temperature	127
4.2 Altitude and Atmospheric Pressure	128

4.3 Heat Output	129
4.4 Acoustic Specifications	132
Chapter 5 Electrical Requirements	135
5.1 Power Requirements	135
5.1.1 Electrical Requirements	135
5.1.2 Power Distribution	139
5.1.3 Emergency Failure	141
5.1.4 Power Distribution System	143
5.2 Grounding	149
5.2.1 Grounding	149
5.2.2 Power and Grounding Requirements	152
5.3 Interconnections	154
5.3.1 MIS (Master Interconnect System)	154
5.3.2 Cable Channeling	154
5.4 System Cable Information	158
5.4.1 Physical Runs	158
5.5 X-Ray ON Lamp Distribution	170
5.6 Ready For X-Ray Lamp	171
5.7 Door Interlocks	172
5.8 Room Speaker	173
5.9 MAC-LAB System EX	174
5.10 Advantage Windows.	174
5.11 Injectors.	175
5.12 Lighting Specifications	175
5.12.1 Room Light Distribution	175
Chapter 6 Communication Requirements	179
6.1 Network Requirements	179
6.2 Privacy and Security Configuration.	179

Chapter 1 General Requirements

1.1 Objectives & Overview

1.1.1 Object and Scope of this manual

This document is intended as a guide and information resource to properly plan and prepare a site for the installation of an Innova system (Innova IGS 620, Innova IGS 630).

In addition, this document provides references to the pre-installation documents of the various product included with an Innova System.

These documents are intended to assist the Installation Specialist and the Site Planner in properly preparing a site for the installation of this system.

It provides pre-installation data, such as site preparation prior to the delivery of the Innova System, environmental and electrical requirements and some additional planning aids.



MAKE SURE THE ROOM PREPARATION COMPLIES WITH LOCAL REGULATIONS
AS THE PIM IS NOT INTENDED TO REFLECT ALL OF THEM

1.1.2 Pre-Installation Process

Complete the checklists in *ROOM LAYOUTS*, *ELECTRICAL CONNECTIONS*, and *ADDITIONAL PLANNING AIDS* of this manual. They represent an important part of the pre-installation process. The checklists summarize the required preparations and allow to verify the proper completion of the pre-installation procedures.

You will find hereafter a chart of the information flow in the pre-installation process.

Figure 1

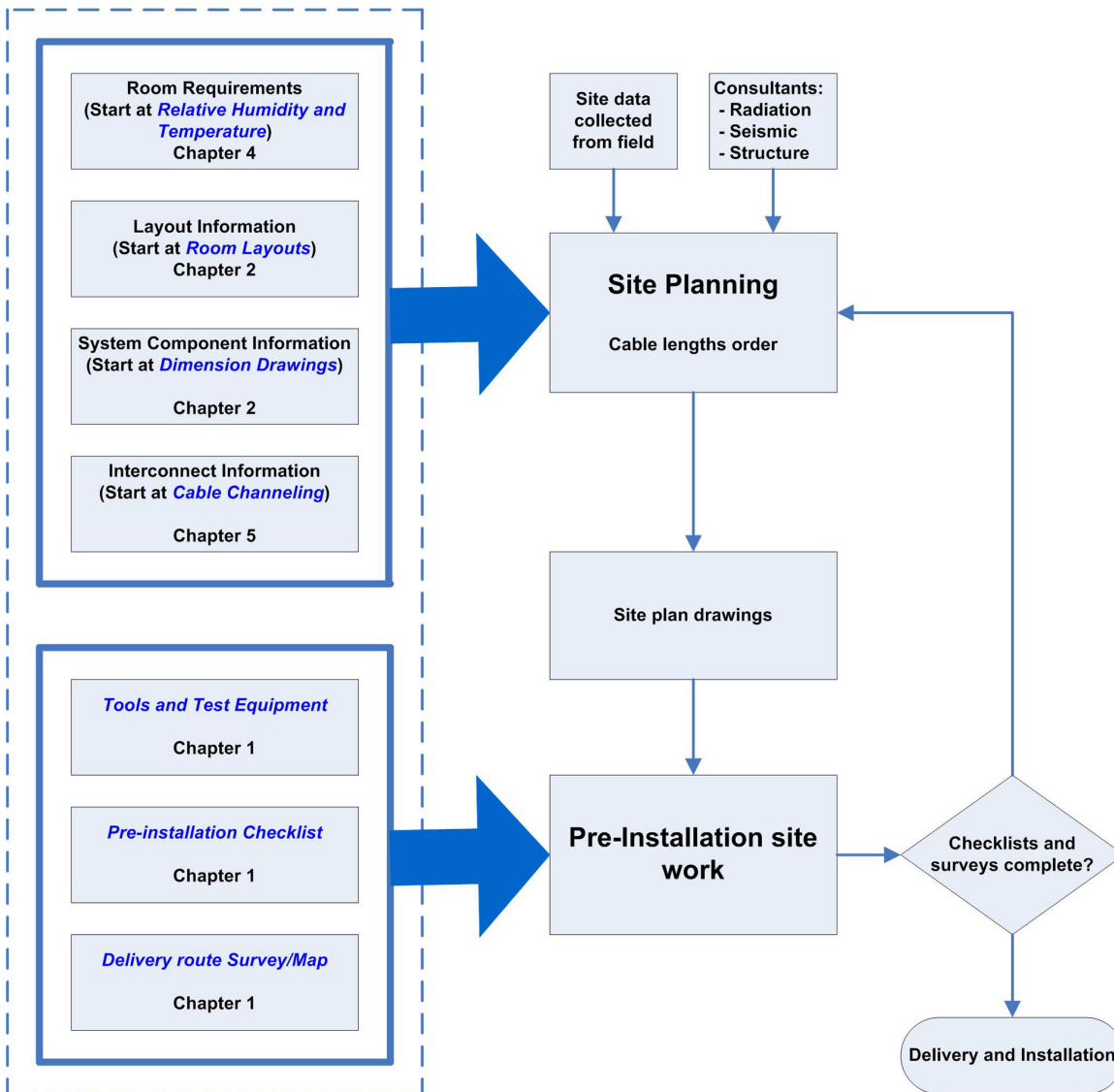

1.2 Customer Responsibilities

1.2.1 Responsibilities of the Purchaser/Customer

To ensure that the installation of an Innova System meets the purchaser or customer expectations, it is important to determine who will take responsibility for the various items during the system installation process. To help you in determining these responsibilities, review the following checklists with the customer and assign responsibilities as appropriate:

- Tool and Test Equipment (1.3.2 Tools and Test Equipment on page 19)
- Pre-Installation Checklist (1.2.3 Pre-Installation Checklist on page 4)

Contract Changes:

Be sure to inform the customer that the cost of any alteration or modification not specified in the sales contract are liable to the customer.

The following GE-supplied equipment must be installed by the Hospital's Contractors, per room drawings:

- PDB (Electrical Power Distribution Box or *Main Disconnect Panel*)
- Frontal Gantry & Table baseplates with holes drilled (Per supplied template)
- Lateral Gantry Suspension stationary rails (centered on Frontal Gantry/table floor template)
- **(For Suspension with rails)** Monitor suspension stationary rails
- **(For LDM Suspension with fixed point Dual Arm)** Substructure for Dual Arm suspension (S18391MX)

NOTE

Means necessary to anchor of the Substructure for Dual Arm suspension (anchors, bolts, screws, etc.) are not delivered with the kit and should be provided and designed under customer responsibility.



- Lateral Gantry cable drape rail(s)
- Frontal Gantry baseplate grout
- Frontal Gantry baseplate
- Table baseplate (if applicable)

NOTE

For systems with Fluoro UPS CE cabinet only: It is the customer responsibility to install a fire extinguisher (non-water type, ex. CO2) in the technical room, close to the Fluoro UPS CE cabinet location.

1.2.2 Equipment Classifications

The following equipment classifications are applicable to the product:

Classification category	Equipment classification
Protection against electric shock	Class I.   TO AVOID THE RISK OF ELECTRIC SHOCK, THIS EQUIPMENT MUST ONLY BE CONNECTED TO A SUPPLY MAINS WITH PROTECTIVE EARTH.
Degree of protection against electric shock	Type B applied parts  Applied parts complying with the specified requirements of the IEC 60601-1 standard to provide protection against electric shock, particularly regarding allowable patient leakage current and patient auxiliary current, include Mattress.
Degree of protection against harmful ingress of water	Ordinary equipment (enclosed equipment without protection against ingress of water), except footswitch which is a watertight device (protected against the effects of submersion, IPX8).
Method(s) of sterilization or disinfection recommended by the manufacturer	<ul style="list-style-type: none"> • Sterilization: not applicable • Disinfection: refer to Operator Manual (Chapter Safety and Regulatory, section Disinfection), Recommended disinfecting agents.
Degree of safety of application in the presence of a flammable anesthetic mixture with air or with oxygen or nitrous oxide	Equipment not suitable for use in the presence of a flammable anesthetic mixture with air or with oxygen or nitrous oxide
Mode of operation	Continuous operation with intermittent loading

 **NOTICE**

The system can only be installed in an anesthetizing location if that location is classified as Other Than Hazardous as per NFPA 70 clause 517.60

 **NOTICE**

The product is not classified as AP, APG (Equipment not suitable for use in the presence of a flammable anaesthetic mixture with air or with oxygen or nitrous oxide).

1.2.3 Pre-Installation Checklist

Refer to the document *Global Site Readiness Checklist DI - DOC1809666* for standard HPM requirements on Room preparation for Vascular Systems installation.

See also the specific preparation requirements for IGS Systems installation given in sections 3, 4 and 5 of the Tab "Installation Prerequisites" in document *IGS System Installation Prerequisites - DOC2024755*.

NOTE

DOC1809666 and DOC2024755 are available from MyWorkshop.

1.3 Delivery Requirements

1.3.1 Shipping Information

1.3.1.1 Product Shipping Information

Refer to [Table 1 on page 5](#). To obtain shipping information for components not specified in [Table 1 on page 5](#), refer to the appropriate component Pre-Installation Manual listed in [2.1.5 System Compatibility on page 69](#).

Table 1

PRODUCT OR COMPONENT	DIMENSIONS			WEIGHT kg (lbs)	METHOD OF SHIPMENT
	Height mm (in)	Length mm (in)	Depth mm (in)		
Frontal Positioner	1950 (77)	2790 (110)	1160 (45.5)	1060 (2,340)	Shipping Dolly. See Figure 2 on page 7
	2300 (90.5)	2900 (114)	1380 (54.5)	1200 (2,645)	Air shipment. See Figure 3 on page 8
Lateral Positioner (on longer dolly)	2135 (84)	2954 (116.3)	1590 (62.5)	1225 (2700)	Shipping Dolly. See Figure 4 on page 9
Lateral Positioner (on shorter dolly)	2135 (84)	2790 (109.8)	1590 (62.5)	1225 (2700)	Shipping Dolly. See Figure 5 on page 11
Omega Table Base Assembly	810 (32)	1950 (76.75)	820 (32.33)	585 (1,290)	On pallet See Figure 7 on page 13
Omega Table Top Assembly	220 (9)	3470 (137)	840 (33)	70 (155)	On pallet See Figure 7 on page 13
C1 Frontal Cabinet	2140 (84.2)	1200 (47.2)	820 (32.2)	457.2 (1008)	In crate on pallet. See Figure 8 on page 14
C1 Lateral Cabinet	2140 (84.2)	1200 (47.2)	820 (32.2)	404.2 (891)	
C2 Cabinet	2140 (84.2)	1200 (47.2)	820 (32.2)	352.2 (776)	

continued					
PRODUCT OR COMPONENT	DIMENSIONS			WEIGHT kg (lbs)	METHOD OF SHIPMENT
	Height mm (in)	Length mm (in)	Depth mm (in)		
Power Distribution Box (PDB) CE	2040 (80.3)	940 (37)	720 (28.3)	238 (525)	See Figure 9 on page 15
Power Distribution Box (PDB) UL	762 (30)	2438 (96)	1067 (42)	548 (1206)	See Figure 10 on page 16
DL User parts	1040 (41)	860 (33.9)	680 (26.8)	100 (220)	On pallet
X-Ray tube housing	960 (37.7)	770 (30.3)	710 (28)	113 (250)	On pallet
Chiller Coolix 4100	1200 (47.2)	555 (21.8)	610 (24)	120 (264.5)	On pallet
Cables					On pallet
Monitor susp. bridge	640 (25.2)	980 (38.6)	3060 (120.5)	210 (445)	On pallet
Monitor susp. rails	380 (15)	300 (12)	5960 (235)	160 (355)	On pallet
UL Fluoro UPS cabinet (*)	2100 (82.7)	890 (35)	1000 (39.4)	561 (1235)	On pallet
CE Fluoro UPS cabinet (*)	1750 (68.9)	890 (35)	1000 (39.4)	585 (1287)	On pallet
Large Display Monitor (Eizo and Barco)	1050 (41.3)	1500 (59)	800 (31.4)	95 (209)	On pallet, see Figure 11 on page 16
Large Display cabinet	1600 (63)	950 (37.4)	750 (29.5)	192 (423)	On pallet, see Figure 12 on page 17
LD system suspension	1100 (43.3)	1100 (43.3)	1850 (72.8)	168 (370)	On pallet
MAVIG suspension with fixed point dual arm for LDM	1860 (73.2)	2150 (84.6)	900 (35.4)	370 (815.7)	On pallet, see Figure 13 on page 18
Substructure for Dual Arm suspension	330 (13)	1040 (41)	490 (19.3)	70 (154.3)	On pallet, see Figure 14 on page 19
LD system handle	400 (15.7)	950 (37.4)	1650 (65)	7 (15)	Cardbord box
LD suspension 36 m harness	230 (9)	800 (34.5)	800 (34.5)	62 (134)	On pallet
LDM UPS	570 (22.4)	320 (12.6)	485 (19.1)	37.5 (82.7)	On pallet

(*) Estimated values

1.3.1.2 Detail of Innova Shipping Information

1.3.1.2.1 Frontal Positioner Gantry on Shipping Dolly

Figure 2 Frontal Positioner Gantry on Shipping Dolly

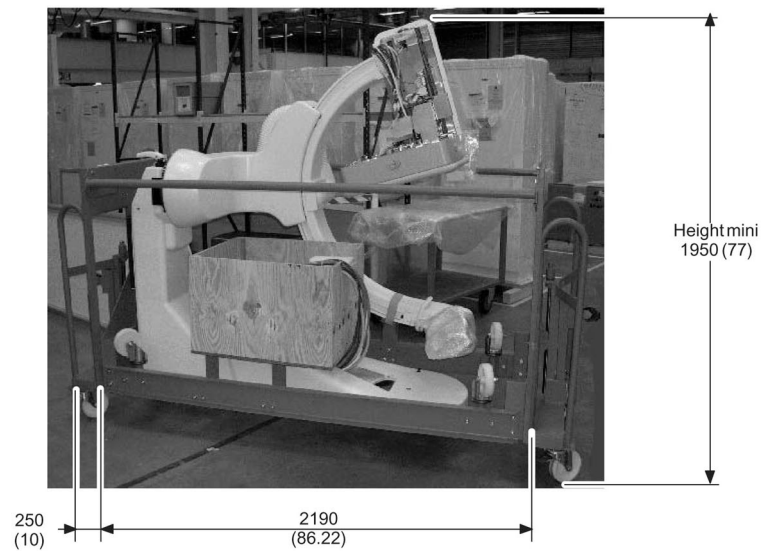

All dimensions are in mm (in inches)

1.3.1.2.2 Frontal Positioner Air Shipment

Figure 3 Frontal Positioner Air Shipment

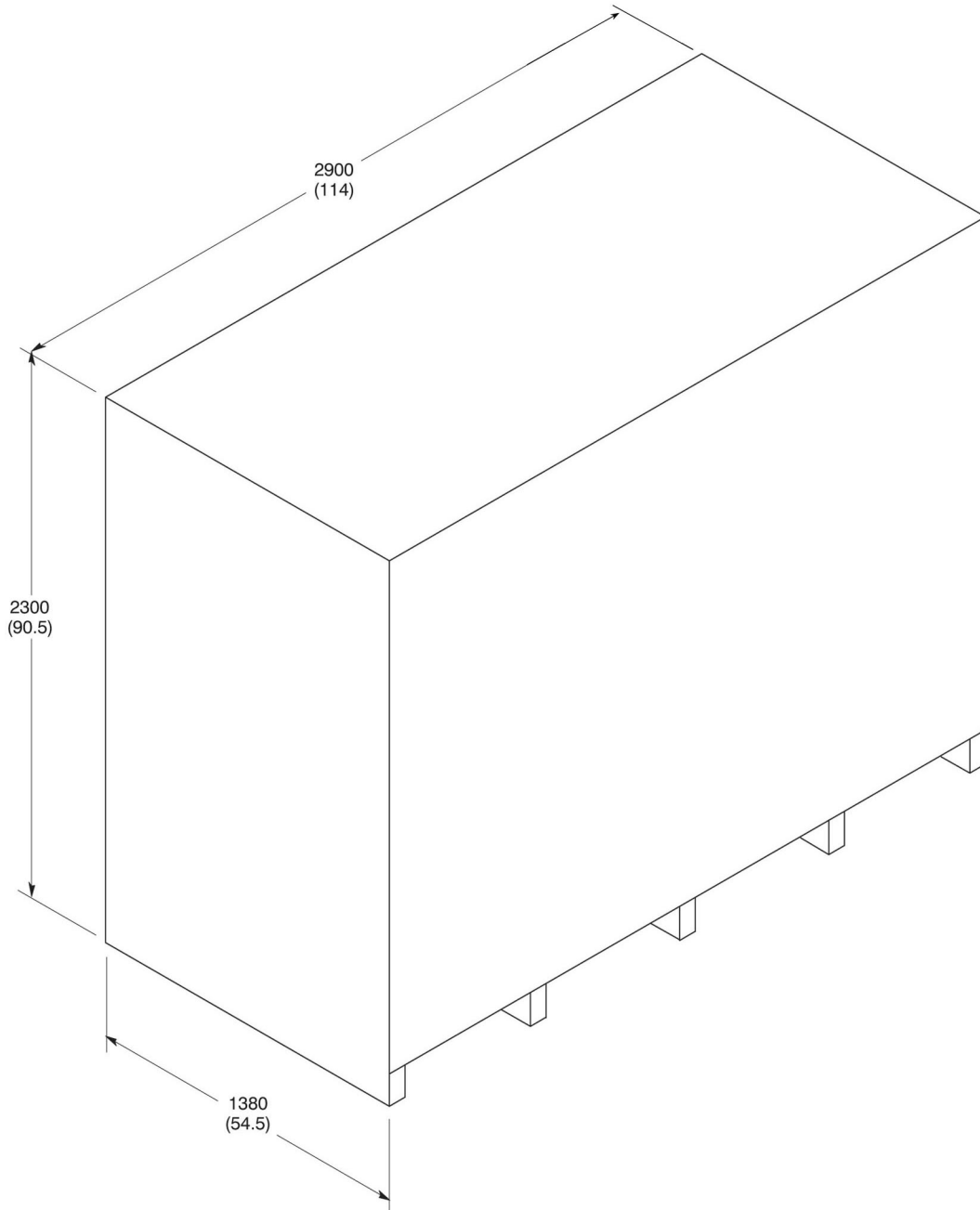

DIMENSIONS IN MM (INCHES)

NOT TO SCALE

1.3.1.2.3 Lateral Positioner on Shipping Dolly (Longer and shorter dollies)

Figure 4 Lateral Positioner on longer type Dolly

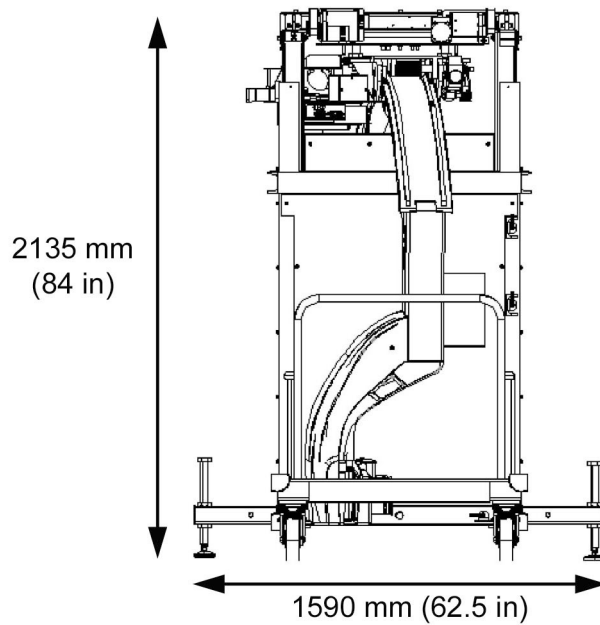
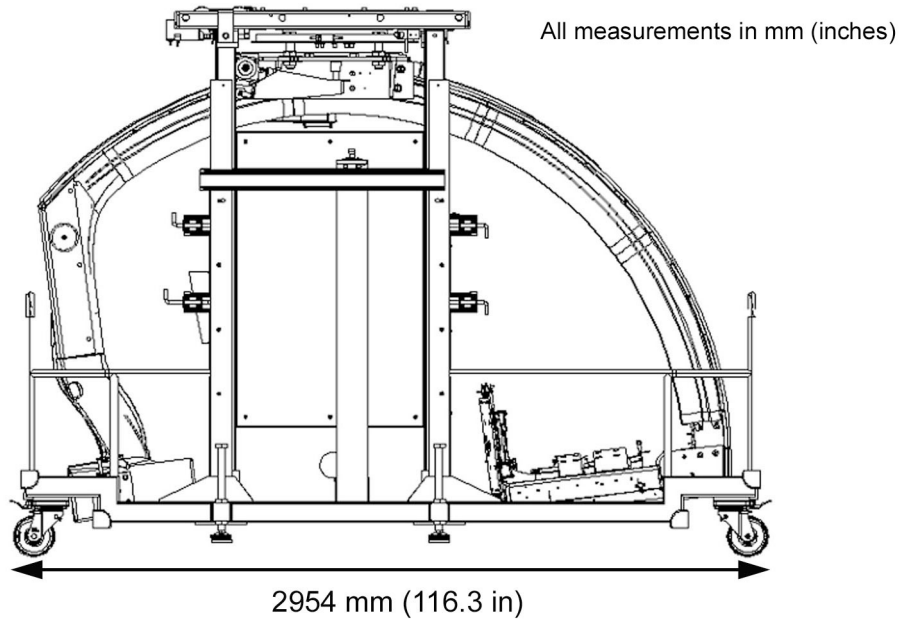

LP4 weight : 670kg (1477 lbs)
Dolly weight : 555 kg (1223 lbs)

NOTE

The dimensions above are for shipping. When the Lateral Positioner and dolly are in rolling configuration for hospital access, the dimensions are Height : 2001 mm (78.8 in) and width : 1040 mm (41 in).

Figure 5 Lateral Positioner on shorter type Dolly

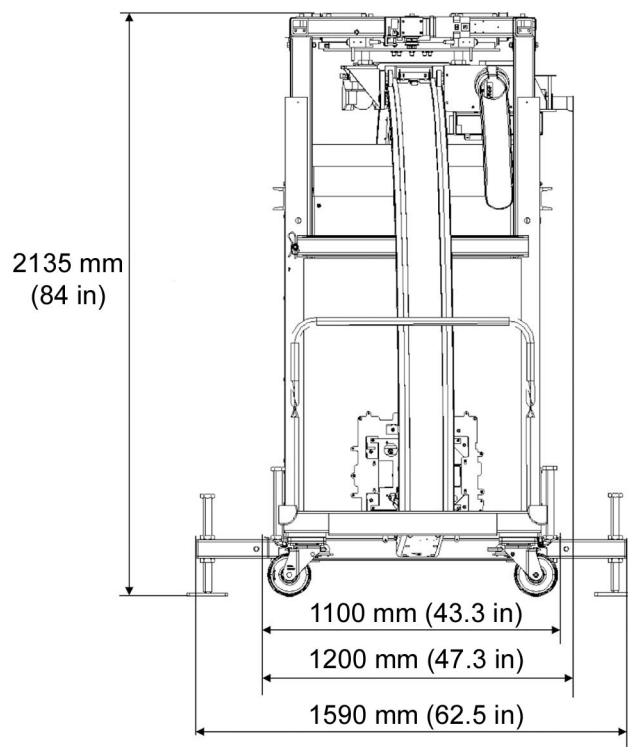
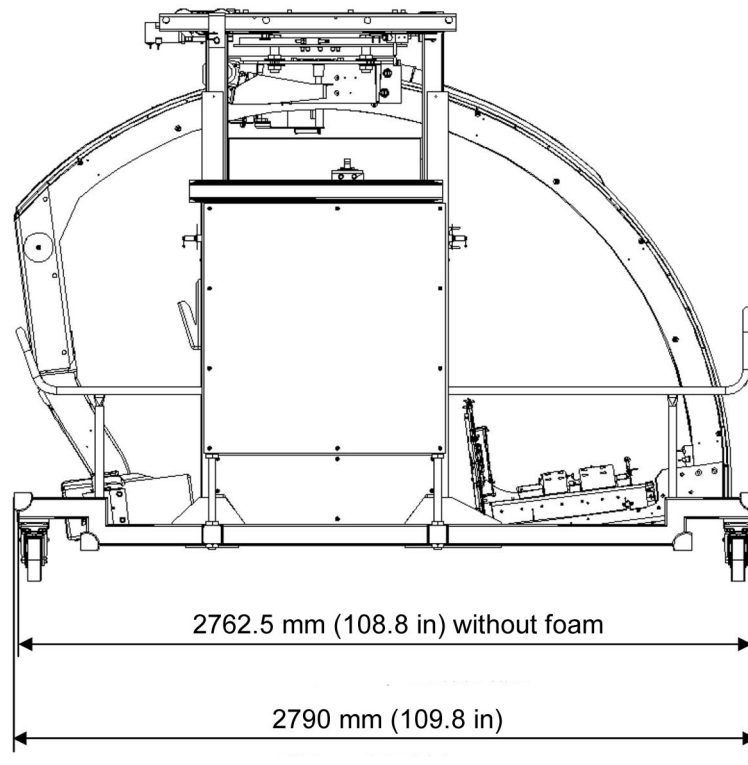

1.3.1.2.4 Lateral Positioner Stationary Rails Packaging

Figure 6 Lateral Positioner Stationary Rails Shipment

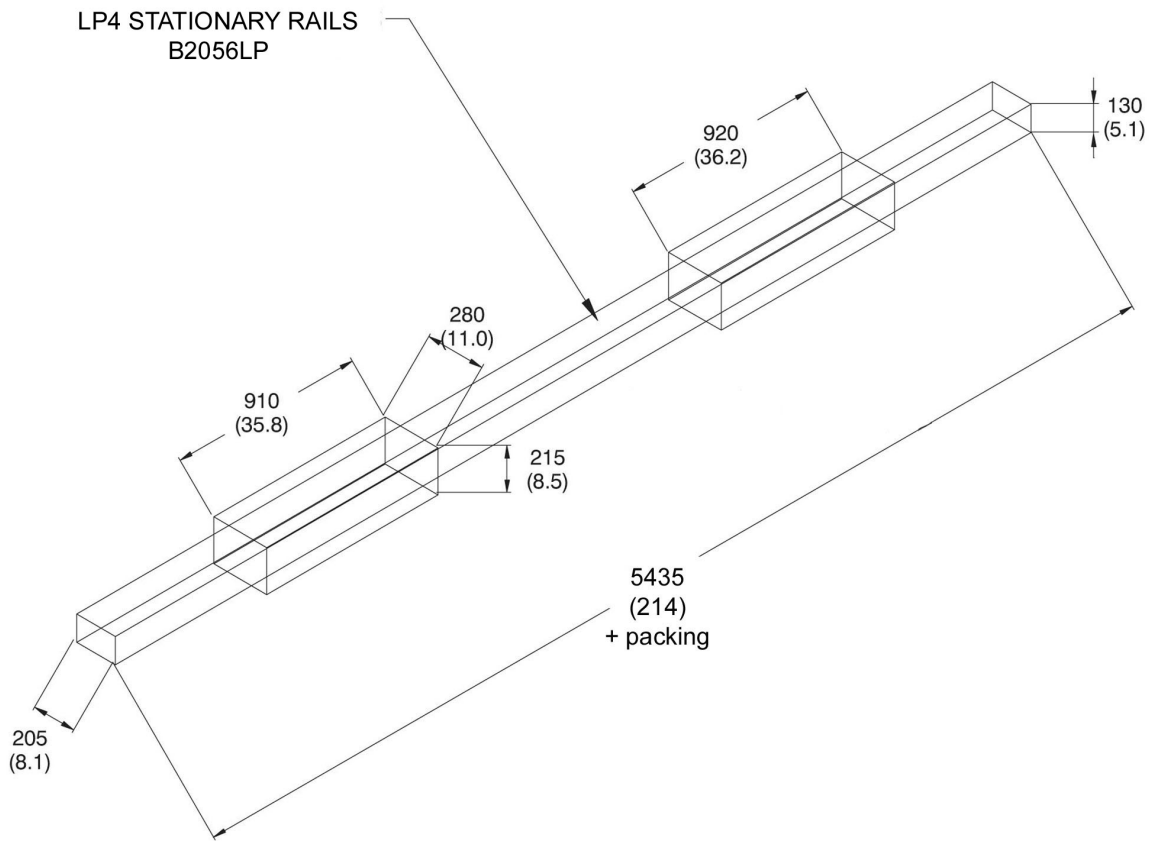

All dimensions are in mm (in inches)

1.3.1.2.5 Omega Table Shipment

Figure 7 Omega Table Shipment

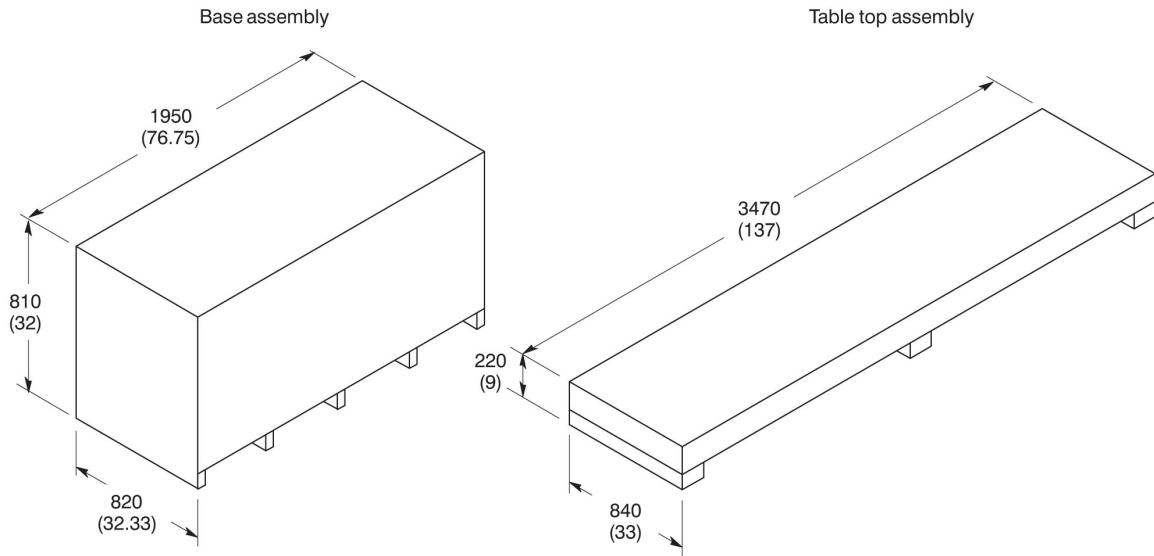

DIMENSIONS IN MM (INCHES)

NOT TO SCALE

1.3.1.2.6 Innova C1 Frontal, C1 Lateral, and C2 Cabinets (Frontal and Lateral)

Figure 8 C1 and C2 Cabinets in crate



The shipping weight is of about 90 kg (198.5 lbs) per cabinet.

NOTE

Please use appropriate transportation and lifting means when handling the system cabinets. Professional handling is required.

1.3.1.2.7 Power Distribution Box (PDB) CE

Figure 9 PDB CE Shipment

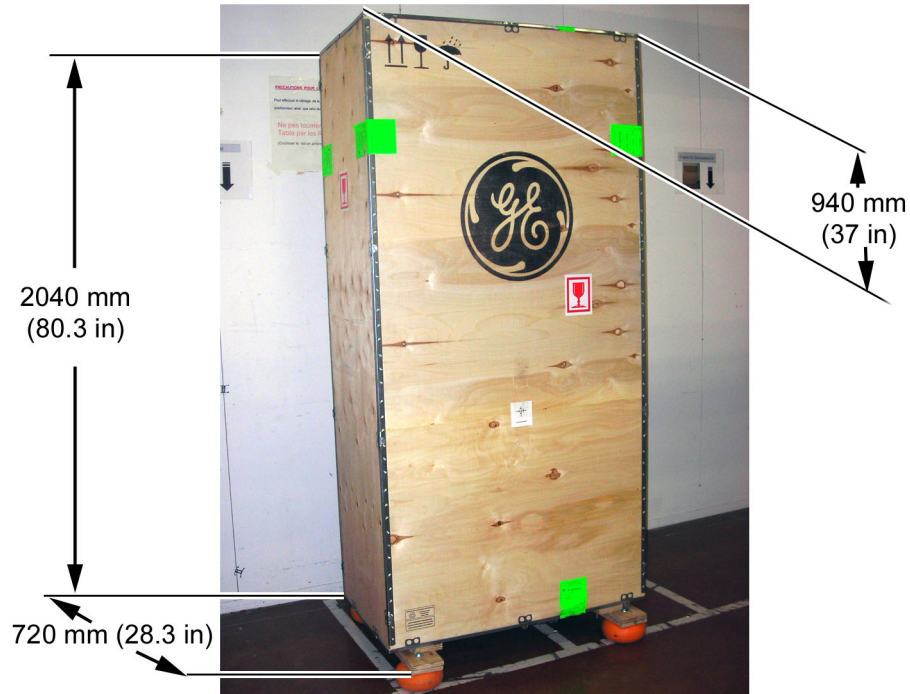

1.3.1.2.8 Power Distribution Box (PDB) UL

Figure 10 PDB UL Shipment

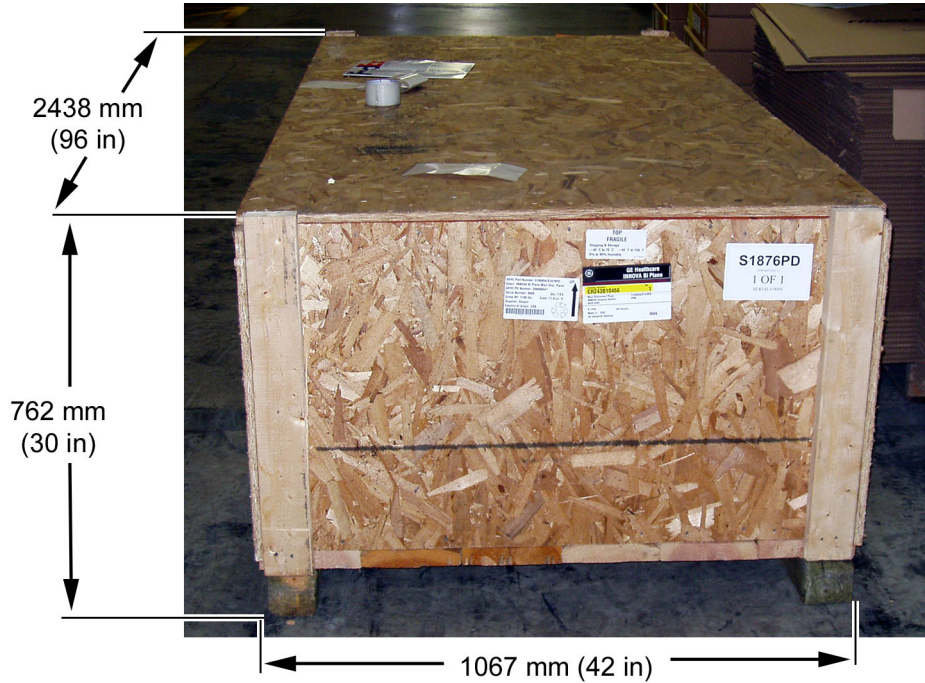

1.3.1.2.9 Large Display Monitor (Option)

Figure 11 Large Display Monitor Shipment



Figure 12 Large Display Cabinet on pallet

Measurements in mm (inches)

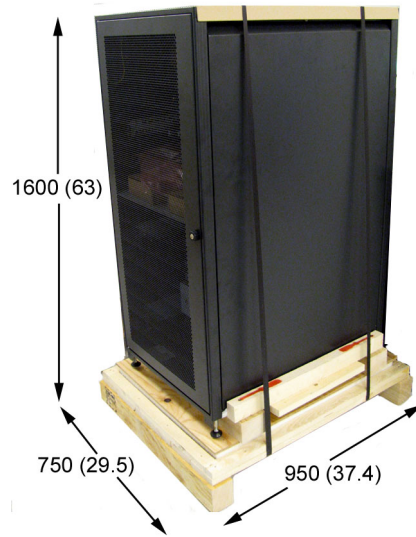

1.3.1.3 Large Display Monitor suspension with fixed point dual arm

1.3.1.3.1 MAVIG suspension with fixed point dual arm for Large Display Monitor

Figure 13 MAVIG suspension with fixed point dual arm Shipment

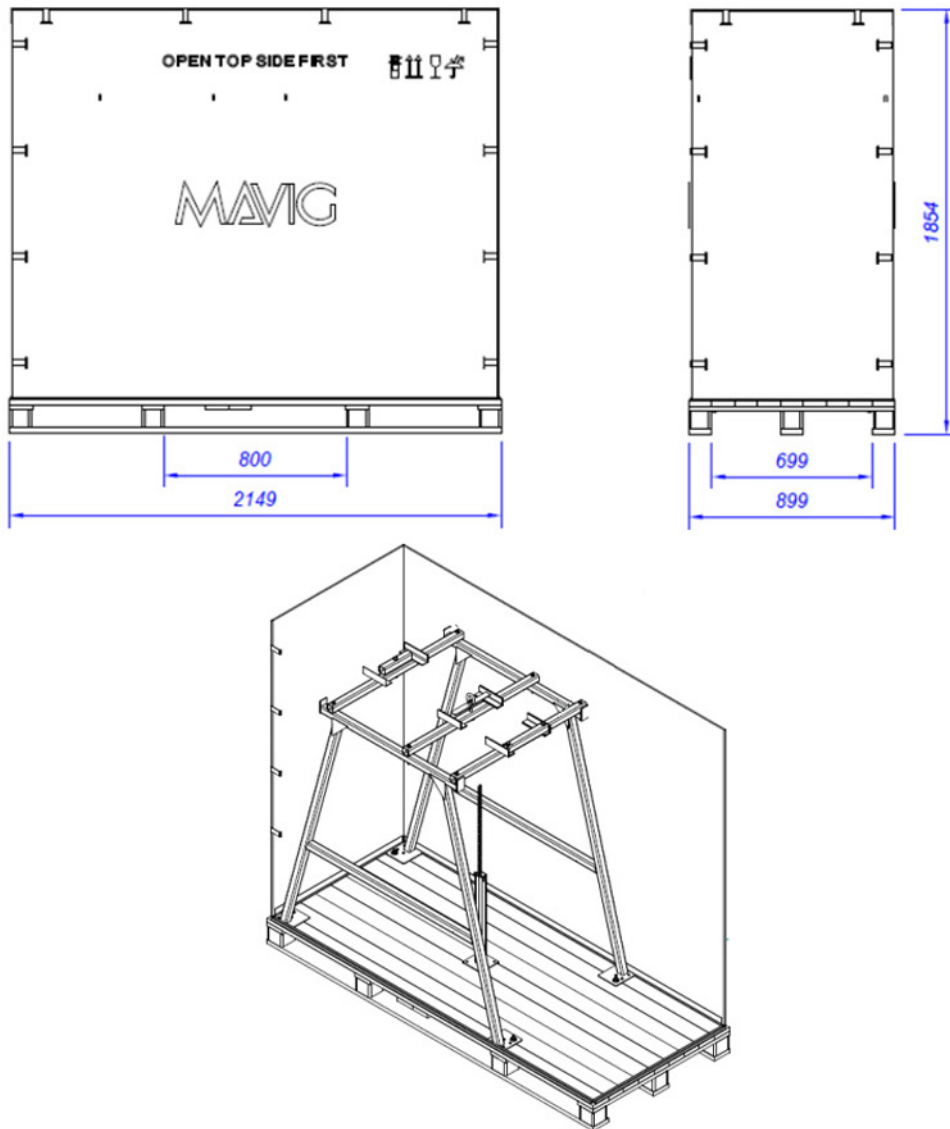

1.3.1.3.2 Substructure for Dual Arm suspension

Figure 14 Shipment of Substructure for Dual Arm suspension

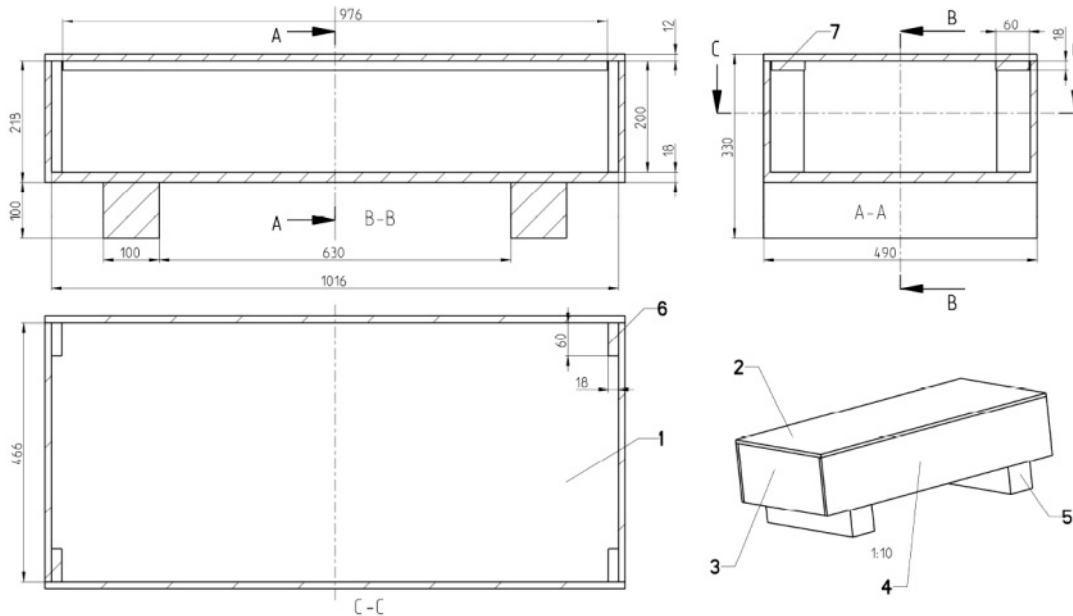

1.3.1.4 Other Elements Package

NOTE

All OEM parts are shipped inside there original boxes group as needed on pallets.

Figure 15 Other Standard Shipping Box

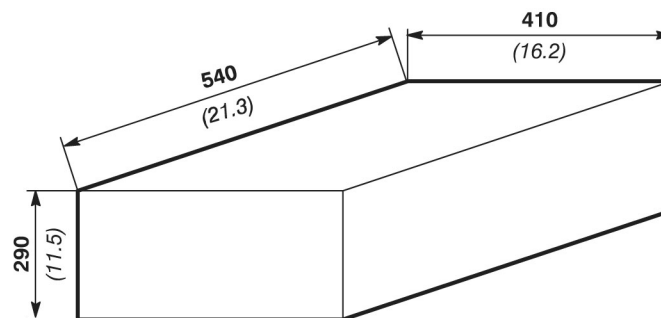

1.3.2 Tools and Test Equipment

Refer to [Table 2 on page 20](#). To obtain a list of tools and test equipment for components not specified in [Table 2 on page 20](#), refer to the appropriate component Pre-Installation Manual listed in [2.1.5 System Compatibility on page 69](#).

Table 2

PRODUCT OR COMPONENT	TOOL OR TEST EQUIPMENT	USED FOR	SOURCE	RECEIVED (DATE)
Frontal Positioner	Service Engineer's Tool Case	General Use		
	Level, Protractor Type	Positioner Checks		
	Torque Wrench 2 to 20 daN.m (15 ft. lbs. to 150 ft. lbs.)	Positioner Checks		
	1/2 inch Ratchet Wrench (2)	Raise and Lower Positioner shipping dolly		
	InGrid/HV Tank "Chucking tool" or wrench, P/N 2131328	High Voltage Cable Installation		
	Laptop Computer (MS-DOS Windows)	Positioner Configuration and Calibration		
Lateral Positioner	Ladders	Installation		
	Lateral Positioner Toolcase (shipped with Lateral Positioner) (For USA and Japan) The toolcase must be ordered from Service Tool Pool	Installation		
	5-axis Laser Alignment tool (shipped with Lateral Positioner Toolcase)	Installation		
	Service Engineer's Tool Case	General Use		
	Level, Protractor Type	Positioner Checks		
	InGrid/HV Tank "Chucking tool" or wrench, P/N 2131328	High Voltage Cable Installation		

continued				
PRODUCT OR COMPONENT	TOOL OR TEST EQUIPMENT	USED FOR	SOURCE	RECEIVED (DATE)
	Torque Wrench 2 to 20 daN.m (15 ft. lbs. to 150 ft. lb)	Positioner Checks		
Omega Table	Same as for Frontal Positioner (Service Engineer's Tool Case)			
C2 Cabinet (Frontal and Lateral)	Same as for Frontal Positioner (Service Engineer's Tool Case)			
C1-Frt and C1-Lat Cabinets	Same as for Frontal Positioner (Service Engineer's Tool Case)			
	Same as for Frontal Positioner (Service Engineer's Tool Case)			
DL User parts				
Monitor Suspension	Ladders	Installation		
	(For Suspension with rails) XT Lifting Tool (x2) 46-156940G3	Installation		
	(For LDM Suspension with fixed point Dual Arm) Installation tool and Peli case (P/N 5758418)	Installation		
Chiller	Phillips/Flathead screwdriver	Open chiller. Install wiring and hoses		
Chiller Autotransformer (Coolix 4100)	Phillips/Flathead screwdriver	Open chiller auto-transformer. Install wiring and hoses		
Large Display Monitor (Option)	Large Display Monitor Lifting Tool	Raise Large Display Monitor for installation on Mavig suspension		

1.3.3 Door Size Requirements

Minimum door sizes also apply to hallways and elevators. For additional details, refer to [1.3.1 Shipping Information on page 5](#)

1.3.3.1 Door Height

The minimum door height (to accommodate Innova positioner on its dolly) is **2001 mm** (78.8 in).

1.3.3.2 Door Width

The minimum door width needed (to accommodate the Innova Frontal/Lateral shipping dolly) is 1040 mm (41 in) with the cable inlet and the dolly stabilizers removed.

NOTE

Door widths are based on a *straight-in* approach requiring a 2440 mm (96 in) wide corridor. Calculations need to be made for accommodation of equipment through narrower corridors.

1.3.3.3 Elevator Depth

The minimum elevator depth needed to accommodate the Innova Gantry shipping dolly is 2954 mm (116.3 in).

1.3.4 Route Survey

1.3.4.1 Step One — Sketch

Start preparing Route Survey by sketching a floor plan of the hospital or clinic which will receive the equipment. Include all areas on the delivery route from outside the building to destination. See [Figure 16 on page 23](#).

Reference Numbers: Numbers in circles refer to Route Survey data. The Route Survey is a form on which site data are listed (see [Step Two — Survey on page 23](#)).

Figure 16

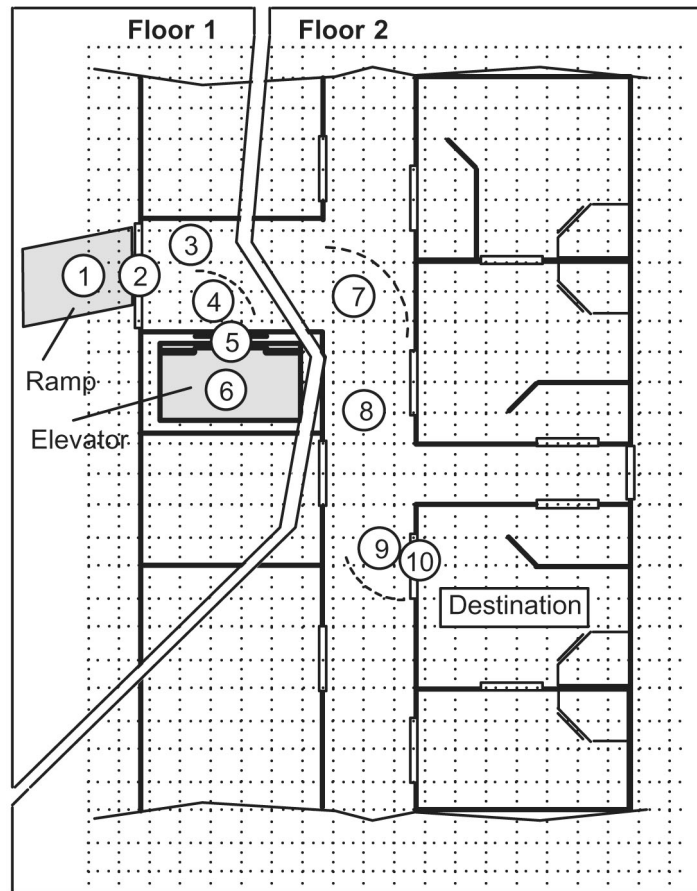

1.3.4.2 Step Two – Survey

Data concerning the intended delivery route are recorded on the Route Survey in the following pages. Record all loading capacities, corridor widths, door openings, turning radii, flooring materials, elevator sizes, obstructions and so on.

1.3.4.3 Step Three – Check

Verify equipment can be transported via the route specified in [Step One – Sketch on page 22](#). Compare Route Survey compiled in [Step Two – Survey on page 23](#) to equipment specifications in this and other applicable pre-installation directions.

Table 3

Route Survey		
Ref. no.	Area: loading dock, doorway, hallway, turn, elevator, obstruction, etc.	Limitations: loading capacity, height, width, depth flooring material, radius, etc.

Storage and transport – Relative Humidity and Temperature continued				
SUB-SYSTEM COMPONENTS	RELATIVE HUMIDITY (NON-CONDENSING) (see NOTE (2))		TEMPERATURE	
	MIN	MAX	MIN	MAX
Monitor LCD Eizo	5%	95%	-20°C -4°F	+60°C +140°F
Monitor LDM	10%	90%	-20°C -4°F	+55°C +131°F
Cabinets C1 Frt, C1 Lat, C2	10%	100%	-40°C -40°F	+70°C +158°F
UPS 3 kVA, 1 kVA	5%	90%	-20°C -4°F	+40°C +104°F
Power Distribution Box (PDB) CE	5%	95%	-30°C -22°F	+70°C +158°F
Power Distribution Box (PDB) UL	10%	95%	-30°C -22°F	+70°C +158°F
UL Fluoro UPS cabinet (*)	0%	95%	-20°C -4°F	+50°C +122°F
CE Fluoro UPS cabinet (*)	0%	95%	-20°C -4°F	+50°C +122°F
LDM cabinet LD core	5%	95%	-40°C -40°F	+70°C +158°F
Detector conditioner	5%	95%	-40°C -40°F	+70°C +158°F
Tube chiller Coolix 4100	10%	100%	-40°C -40°F	+70°C +158°F
VCIM	5%	95%	-40°C -40°F	+70°C +158°F
Digital detector	Refer to NOTE (1) below			

NOTE

(1): The **detector** should be stored at 10 to 40 °C (50 to 104 °F) and less than or equal to 90% RH in the plastic wrapped shipping box. (This should include two bags of desiccant as well). The lowest temperature (e.g. 10 °C (50 °F)) and humidity is preferable. If they are to be stored outside of their shipping box or in the inner shipping box without plastic wrapping they should be stored at 20 °C (68 °F) or less and 30% RH or less. In terms of transportation, do not expose to temperatures below -20 °C (-4 °F) **in its shipping box** for more than 15 hours. The detector will reach the ambient temperature after 20 to 25 hours. The detector should not be allowed to reach temperatures less than -10 °C (14 °F) or irreparable damage to the detectors scintillator will occur. Care must be taken when removing a detector from a shipping box. If the detector has been subject to cold temperatures for an extended period the detector in the box should be allowed to sit in the plastic wrapped box to reach room temperature. This will prevent condensation from occurring. Condensation on the detector can cause irreparable damage to the electronics. Storage 10 to 40 °C (50 to 104 °F); 10 to 90 % RH, 250 day storage transportation -20 to +60 °C (-4 to 140 °F) and 10 to 80% RH. The Detector Conditioner is shipped within GE Healthcare packaging.

NOTE

(2) Special Humidity Instructions: The following parts can be can be shipped in standard shipment conditions with the requirement that on arrival to installation site, and before supplying power to these parts, they shall be kept in an environmental relative humidity equal or lower than their specified capability, and that’s for a minimum of 48 hours.

- 3 kVA UPS 110 V & 220 V, 1 kVA UPS (Maximum specified relative humidity capability = 90%)
- LDM Monitor (Maximum specified relative humidity capability = 90%)
- CVI Injector (Maximum specified relative humidity capability = 85%)
- Diamantor (Maximum specified relative humidity capability = 80%)
- 1MP MX191 LCD Monitor (Maximum specified relative humidity capability = 80%)

Table 5 Atmospheric Pressure - Storage and transport

SUB-SYSTEM COMPONENTS	ATMOSPHERIC PRESSURE (hPa)	
	MIN	MAX
Frontal Positioner	525	1013
Lateral Positioner	525	1013
Omega Table	48	1220
TSUI (TSSC, Smart box, Smart handle, TPD)	500	1010
Footswitch	500	1060
Monitor LCD Eizo	540	1053
Monitor LDM	200	1050
Cabinets C1 Frt, C1 Lat, C2	500	1060
UPS 3 kVA, 1 kVA	697	1130
Power Distribution Box (PDB) CE	500	1060
Power Distribution Box (PDB) UL	500	1060
UL Fluoro UPS cabinet (*)	500	1013
CE Fluoro UPS cabinet (*)	500	1013
LDM cabinet LD core	700	1060
Detector conditioner	120	1060
Tube chiller Coolix 4100	500	1060
VCIM	525	1013

1.4.2 Fluoro, 3 kVA & 1 kVA UPS Shipment Duration

NOTE

In the case the material shipped will be subject to different temperature values during shipment, the maximum shipment duration can be calculated, depending on the duration of different temperature values application, and using values given in the tables above

1.4.2.1 Fluoro UPS (CE and UL)

The maximum shipment duration is given in the table for both Fluoro UPS CE and UL. It depends on the temperature to which the material will be subject during shipment. This limitation is due to the capability of batteries included in UPS.

Table 6 Maximum shipment duration for Fluoro UPS

Temperature	Shipment max duration (Weeks)
55°C (131°F)	2
50°C (122°F)	3
40°C (104°F)	6
30°C (86°F)	12

1.4.2.2 3 kVA UPS (220 V and 110 V) & 1 kVA UPS

The maximum shipment duration is given in the table for both 3 kVA UPS 220 V and 110 V, and 1 kVA UPS. It depends on the temperature to which the material will be subject during shipment. This limitation is due to the capability of batteries included in UPS.

Table 7 Maximum shipment duration for 3 kVA UPS & 1 kVA UPS

Temperature	Shipment max duration (Weeks)
55°C (131°F)	4
50°C (122°F)	7
40°C (104°F)	14
30°C (86°F)	25

Page intentionally left blank

Chapter 2 Equipment Requirements

2.1 System Components

2.1.1 Presentation of the 3 Rooms

The components shall be installed in three different rooms with different constraints: the Exam Room, the Control Room and the Technical Room.

2.1.1.1 Exam Room

This is where the patient is situated. It contains the table on which the patient is lying, the table side user interfaces (TSUI), the frontal and lateral gantries, the exam monitors, and accessories.

2.1.1.2 Control Room

This room contains user interface and control monitors. No intentional or unintentional contact with the patient shall occur with the patient in this area.

2.1.1.3 Technical Room

This room contains electronic cabinets. No intentional or unintentional contact with the patient shall occur with the patient in this area. It is strongly recommended that this room is separated from the Control Room, in order to minimize risks of transmission of airborne pathogens. Its construction should be adapted to minimize ambient noise level; for example the use of glass doors instead of louvered hung doors.

- 7 - X-Ray Tube cover spacer
- 8 - 21 cm or 31 cm Detector
- Lateral Gantry
 - 9 - Carriage
 - 10 - Pivot
 - 11 - C-Arc
 - 12 - Motorized Elevator for the Detector
 - 13 - X-Ray Tube and Tube Elevator
 - 7 - X-Ray Tube cover spacer
 - 14 - Collimator
 - 15 - 21 cm or 31 cm Detector

2.1.2.1.2 Innova Patient Table

Figure 18 Omega Table

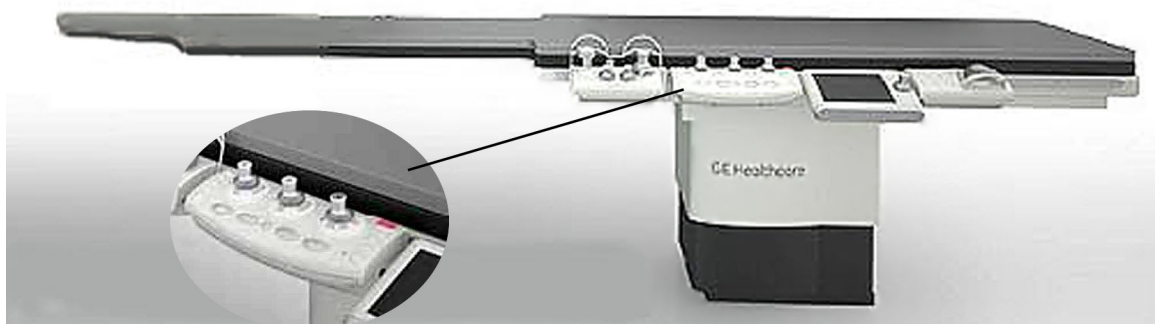

2.1.2.1.3 User Interfaces

Figure 19 User Interfaces



2.1.2.1.4 Monitors

By default:

- Four 19" monitors are provided in the Exam Room:
 - FRT LIVE monitor,
 - FRT REVIEW monitor,
 - LAT LIVE monitor,

- LAT REVIEW monitor.
- Three 19" monitors are provided in the Control Room:
 - FRT LIVE monitor,
 - LAT LIVE monitor,
 - DL monitor.

2.1.2.1.5 Electronic cabinets

The following cabinets are provided with the system:

- C1 frontal cabinet, which contains the High Voltage generator for the frontal gantry, 2 PCs and IT components,
- C1 lateral cabinet, which contains the High Voltage generator for the lateral gantry and 1 PC,
- C2 cabinet, which is in charge of the gantry and table control,
- PDB for Power Distribution (2 different models for UL and CE markets),
- 2 Tube chillers and their autotransformers,
- 2 Detector conditioners,
- 1 kVA UPS



NOTICE

THE ABOVE COMPONENTS ARE NOT CERTIFIED FOR USE OUTSIDE THE TECHNICAL ROOM. IT IS MANDATORY TO INSTALL THEM IN THIS AREA, IT IS FORBIDDEN TO INSTALL THEM IN THE EXAM ROOM.

2.1.2.2 Options

2.1.2.2.1 Large Display Monitor (LDM)

The system can integrate a Large Display solution to:

- see images larger at full IQ with greater flexibility in monitor distance in the procedure room,
- display multiple video images simultaneously at different sizes based on stage of workflow,
- conveniently switch operator defined video layouts at different points in procedure workflow.

This option consists in a 58" color monitor, 2 backup 19" monitors in the Exam Room, a LD cabinet and a UPS in the Technical Room.

2.1.2.2.2 User Interfaces

The user interfaces available as option are:

- In-room AW Mouse interface kit.

NOTE

The dongle and the mouse are not provided in the kit.

- Bolus handle

Figure 20 Optional User Interfaces



2.1.2.2.3 Monitors

According to the subscribed options:

- 2 additional 19" monitors in the Exam Room (Frt Roadmap, Lat Roadmap),
- up to 4 additional 19" monitors in the Control Room (Frt Review, Frt Roadmap, Lat Review, Lat Roadmap),
- up to 12 additional 19" monitors in the Exam Room or in the Control Room.

Table 8 Location of 19" monitors (mandatory and optional)

Video Splitter Output (Frontal and Lateral)	Output 1	Output 2	Output 3	Output 4
Live	Exam Room	Control Room	Exam Room or Control Room	Exam Room or Control Room (1)
Review	Exam Room	Control Room	Exam Room or Control Room	Exam Room or Control Room (1)
Roadmap	Exam Room	Control Room	Exam Room or Control Room	Exam Room or Control Room (1)

NOTE

Text in **bold** for mandatory 19" monitors.

(1): without LDM option.

2.1.2.2.4 Fluoro UPS

The Fluoro UPS solution allows the customer to complete an exam in fluoroscopy mode in case of mains power failure. The autonomy provided by this UPS is 5 minutes of fluoroscopy every 24 hours. It includes the following components:

- Fluoro UPS (2 different model for UL and CE markets),
- EMI filter box (CE market only).

2.1.2.2.5 Monitor suspensions

2.1.2.2.5.1 Six monitors suspension

The common type of this suspension is an XT inboard monitor bridge. A monitor frame receives 6 monitors: 4 monitors for Innova images and 2 color monitors for 3rd party images or optional Innova Images (simultaneous display option).

This suspension is delivered and installed by GE.

2.1.2.2.5.2 LDM suspension

For the systems with the LDM option, a specific suspension can be provided:

- suspension with an XT inboard monitor bridge
- suspension with fixed point dual arm

These suspensions are delivered and installed by GE.

The two backup monitors are mounted on the back of this suspension for faster access in case of failure.

For the second LDM, a wall mounting kit can be provided.

2.1.2.2.5.3 Third party monitor suspension

In addition or replacement of the GE provided suspensions, the customer can install the suspension of his choice ("third party monitor suspension"), provided the requirements below are met:

- The suspension shall be installed by strictly following the GEHC installation instructions. GE Healthcare specifically disclaims any and all liability arising out of or relating to the use or performance of the monitor suspension (including cables), including, without limitation, any liability or claims relating to patient injury, death, or the reliability of such monitors suspension(s).
- The suspension(s) shall comply with the applicable Regulation enforced in the country (eg., when installed in an European Community country, it shall be CE marked).
- All Regulatory Requirements and Pre-Installation Instructions contained in *Third Party Monitor Suspensions – Service Instruction for Installation* contained in the Service manual shall be met.

The association of the Innova product and the purchaser's (customer) monitors suspension(s), is not covered by the product certification.

Third party monitors from external sources can also be installed on these suspensions, but shall not be powered by the system.

Only the monitors provided with the system can be powered by the system:

- 19" monitors: Eizo RX150 GE or Eizo MX193,
- Large Display monitors: Eizo LS580W GE or Barco GEH-8258 L.



THE INNOVA SYSTEM DELIVERED WITH THE THIRD PARTY MONITOR SUSPENSION OPTION CANNOT PRESUME ON THE MECHANICAL CONSTRAINTS OF NON-GE MONITOR(S) SUSPENSION(S) INTRODUCED IN THE SYSTEM.



AVOIDING COLLISION BETWEEN THE GANTRIES AND THIRD PARTY EQUIPMENT IS UNDER CUSTOMER RESPONSIBILITIES.

2.1.2.2.6 Advantage Windows workstation (AW)

The AW workstation option is composed of a workstation, 1 or 2 19" flat panel monitors in the Control Room.

One optional 19" flat panel monitor can be fixed on the Exam Room suspension, or both AW screens can be displayed on the LDM if the option is present.

2.1.2.2.7 CENTRICITY CA1000

Refer to: *Centricity Cardiology CA 1000 V2.0 Preinstallation Guide* (DOC0241470) in the OEM section of the Innova™ IGS 620, Innova™ IGS 630 service manual.

2.1.2.2.8 Injectors

The injectors certified for use with the system are:

- ACIST CVI pedestal,
- ACIST CVI table mount,
- MEDRAD AVANTA pedestal,
- MEDRAD AVANTA table mount,
- MEDRAD Mark 7 pedestal,
- MEDRAD Mark 7 table mount,
- MEDRAD Mark 7 ceiling mount.

NOTE

For MEDRAD Mark 7 table mount and ceiling mount, rack connected to C2 cabinet is located in technical room.

2.1.2.2.9 ECG Acquisition kit

The ECG Acquisition kit allows the connection of an ECG device (such as GE's MacLab, CardioLab or ComboLab) to the system. The ECG Acquisition kit consists of a Hubican and Physio modules and their associated cables; it is compatible with ECG devices installed in the Exam Room and in the Control Room.

2.1.3 Dimension Drawings

Refer to this section for the dimensional drawings of the components of the systems with 21 & 31 cm detector. This section also contains the Frontal Gantry, Lateral Gantry and patient table sweep volume curves. These systems include:

Frontal and Lateral Positioner, Omega Table, C2 Cabinet, C1 Frontal Cabinet / C1 Lateral Cabinet, 1 kVA Cabinet UPS, 3 kVA LDM UPS, Chillers, Optional Fluoro UPS and PDB (main disconnect). In addition, refer to this section for Positioner/table relative position drawings.

Table 9

Product or component	QTY	Illustration
Exam Room		
Frontal Positioner - Side View	1	Figure 21 on page 39
Frontal Positioner - Top View		Figure 22 on page 40
Frontal Positioner - Front View		Figure 23 on page 40
Lateral Positioner - Side View	1	Figure 24 on page 41
Lateral Positioner - Top View		Figure 25 on page 42
Lateral Positioner - Front View		Figure 26 on page 43
Omega V Table	1	Figure 27 on page 44
Omega Table side clearance (CPR access)		Figure 28 on page 46
Table Head Extender	1	Figure 29 on page 47

continued		
Product or component	QTY	Illustration
Gas Box Outlets Omega Table	1	Figure 30 on page 48
Frontal and Lateral Positioner and Omega Patient Table Relative Positions: - Side View	1	Figure 31 on page 49
Frontal and Lateral Positioner and Omega Patient Table Relative Positions: - Top View	1	Figure 32 on page 50
Lateral Positioner Cable Drape Length	1	Figure 33 on page 51
LCD 6 monitors suspension	1	Figure 34 on page 52
(For Suspension with rails) Large Display suspension with rails (Optional)	1	Figure 35 on page 53
(For LDM Suspension with fixed point Dual Arm) Large Display Mavig suspension with fixed point dual arm (Optional)	1	Figure 36 on page 54
		Figure 37 on page 55
Technical Room		
C2 Cabinet	1	Figure 38 on page 56
C1 Frontal Cabinet	1	Figure 39 on page 57
C1 Lateral Cabinet	1	Figure 40 on page 58
Coolix 4100 Chiller	2	Figure 41 on page 59
Thermo-Con Detector Conditioner	2	Figure 42 on page 60
1 kVA Cabinet UPS - model 9130	1	Figure 43 on page 61
3 kVA LDM UPS - model 9130	1	Figure 44 on page 62
Fluoro UPS Cabinets (Optional)	1 (UPS UL)	Figure 45 on page 63
	1 (UPS CE)	Figure 46 on page 64
ECG Acquisition Device Modules	2	Figure 47 on page 65

continued		
Product or component	QTY	Illustration
Large Display Cabinet	1	Figure 48 on page 66
Control Room		
DL Keypad	1	Figure 49 on page 67
DL Image Monitor	1	Figure 50 on page 67
VCIM	1	Figure 51 on page 68

Figure 21 Frontal Positioner dimensions - Side View

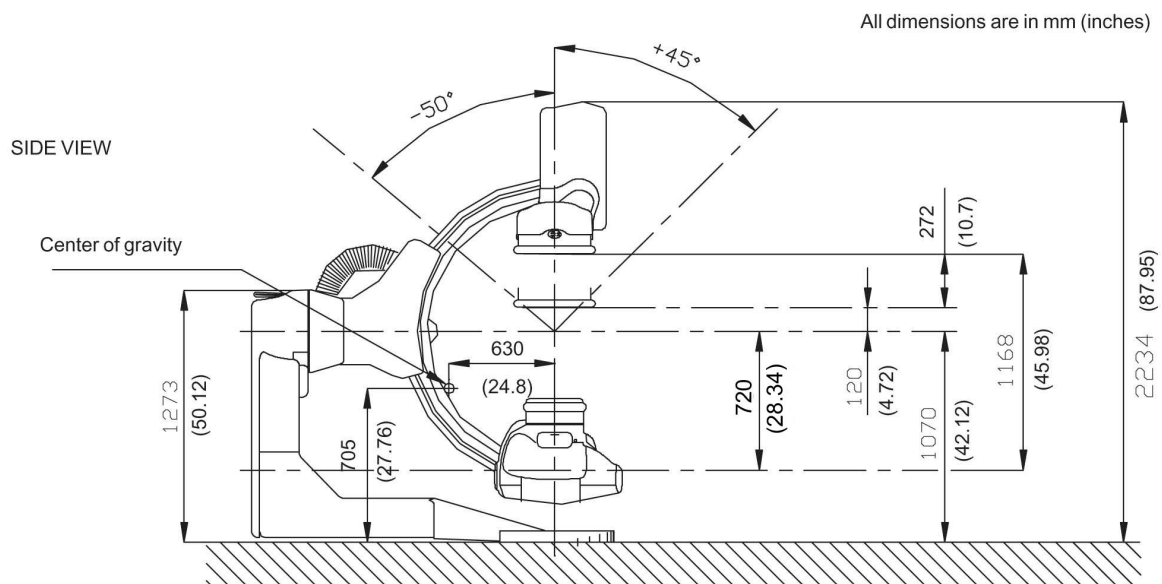

Figure 22 Frontal Positioner dimensions - Top View

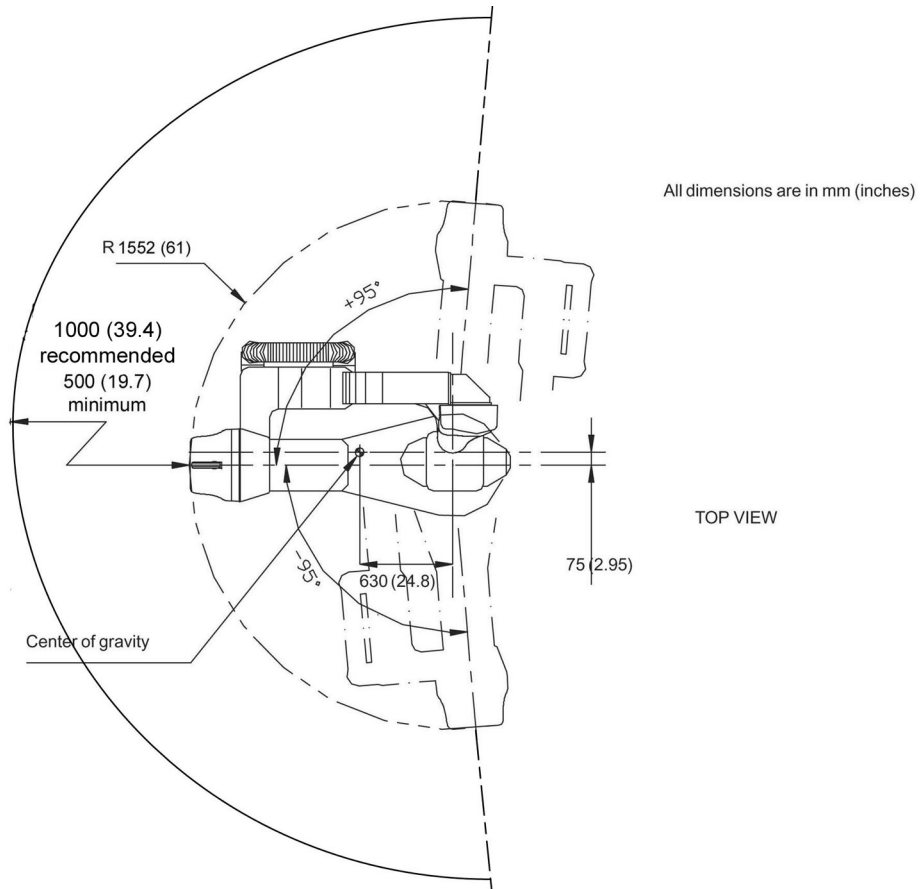

Figure 23 Frontal Positioner dimensions - Front View

Figure 24 Lateral Positioner dimensions - Side View

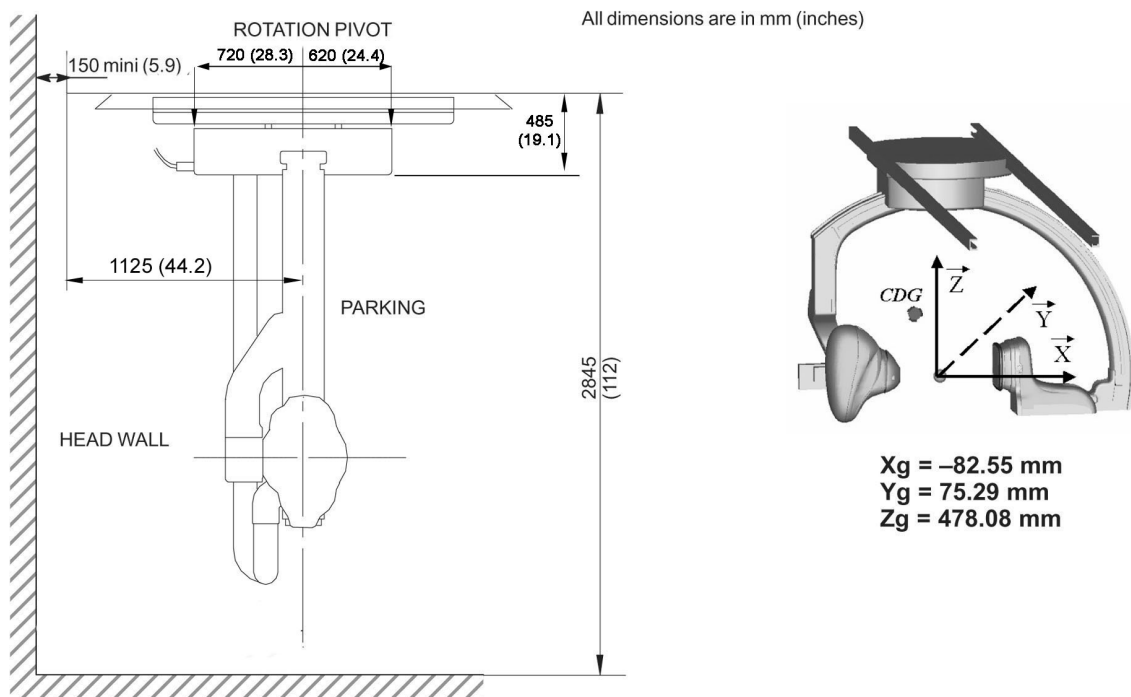

Figure 25 Lateral Positioner dimensions - Top View

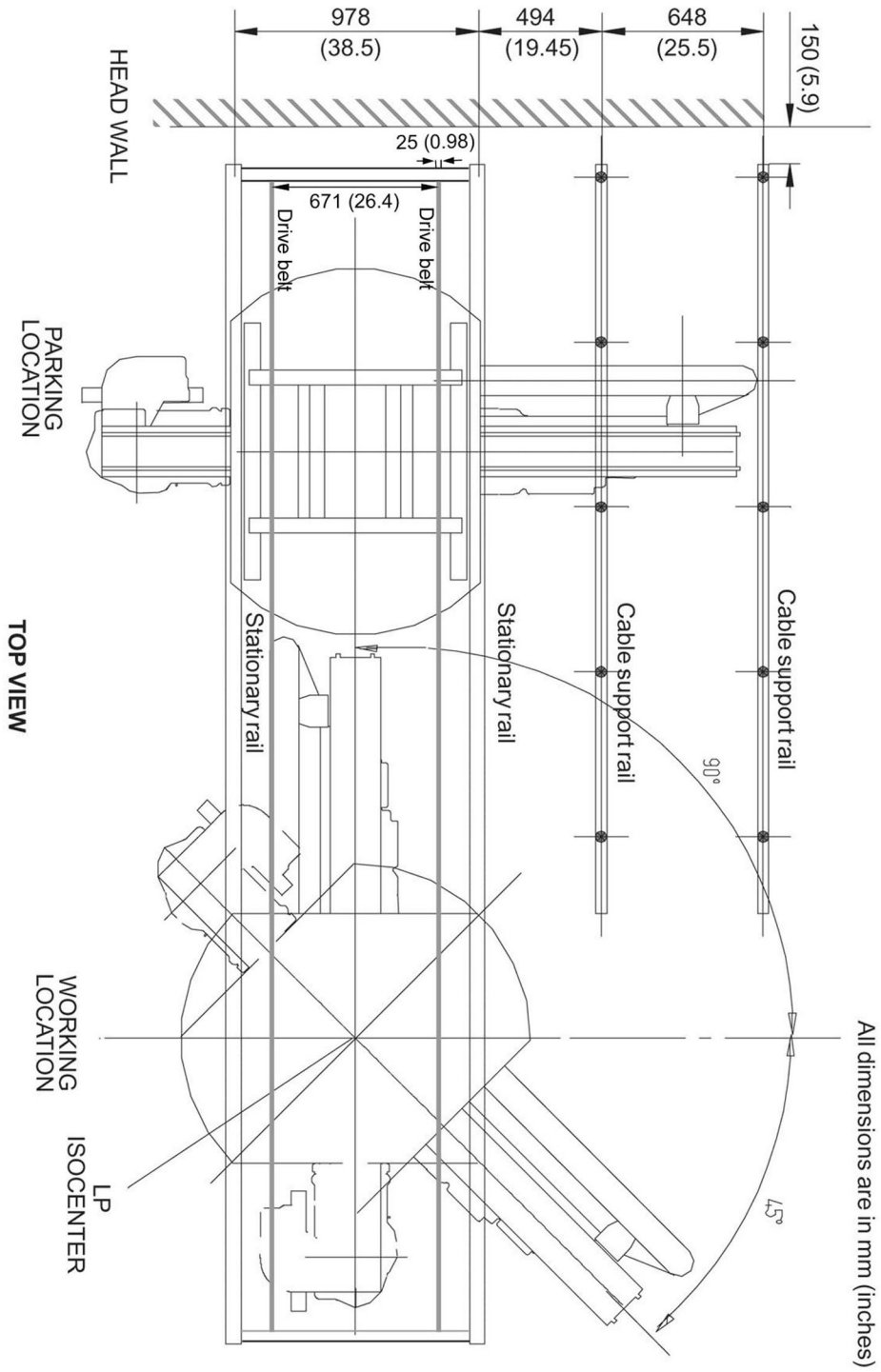

Figure 26 Lateral Positioner dimensions - Front View

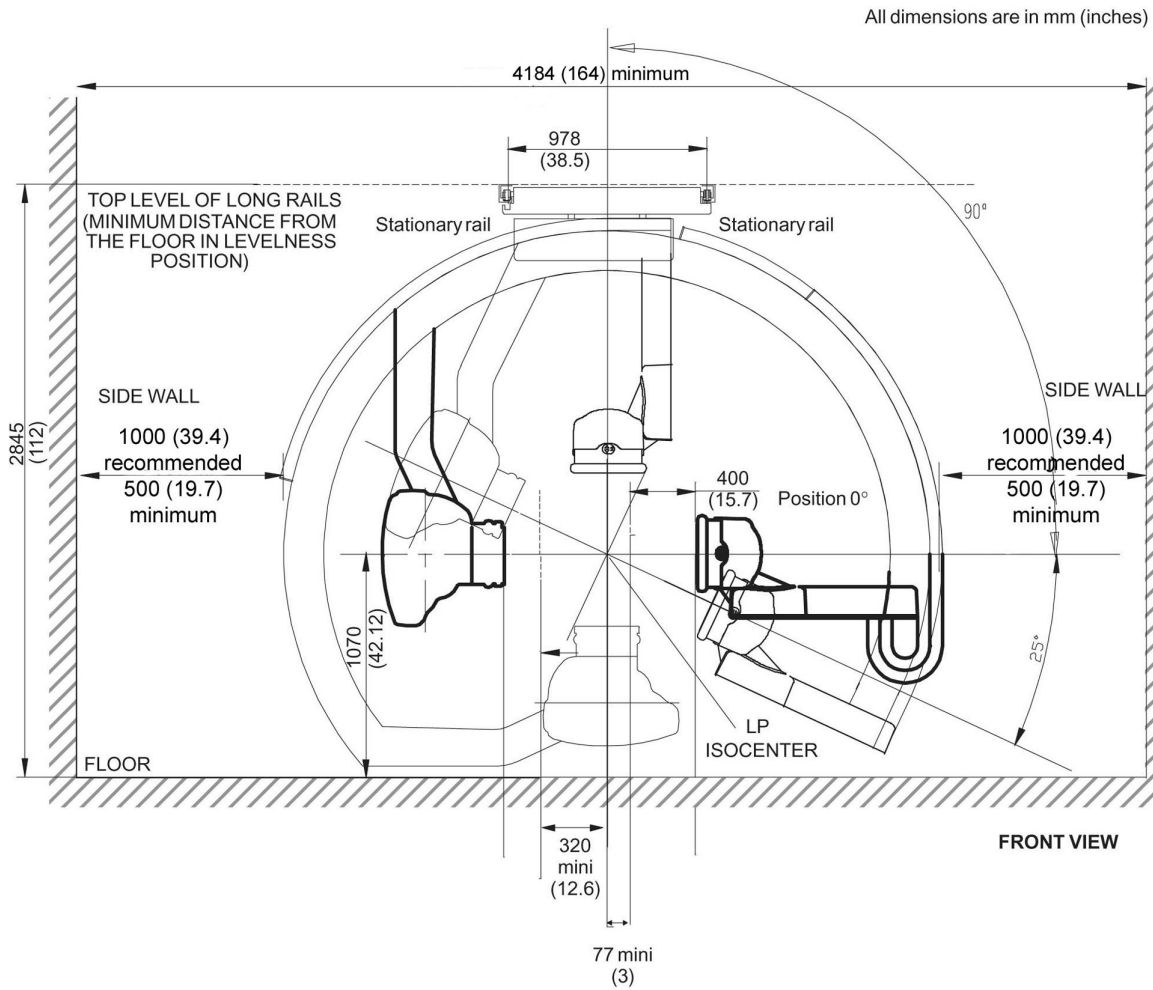
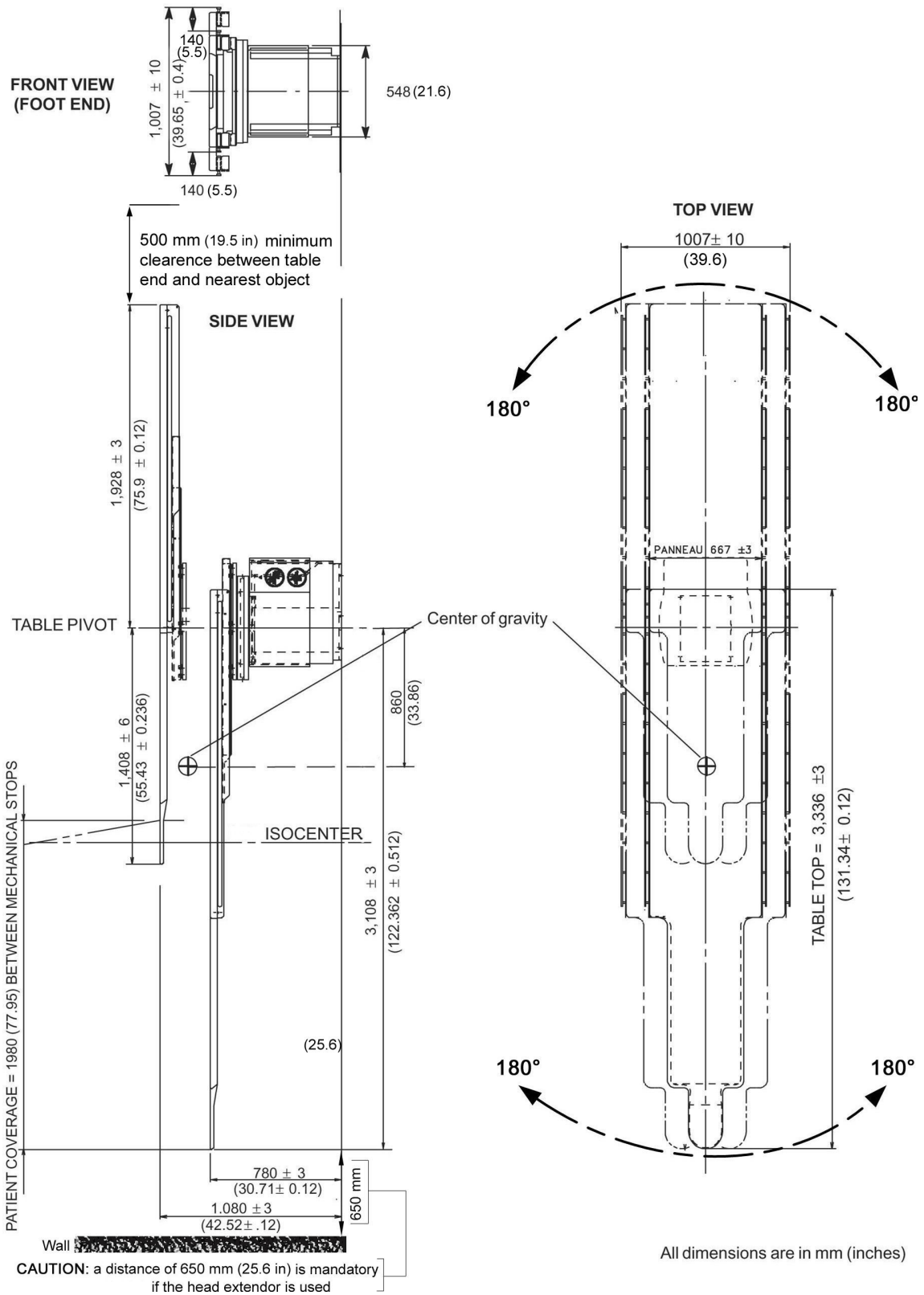

Figure 27 Omega V Table dimensions



NOTE

The 500 mm (19.7 in) minimum clearance between the **table foot end** and nearest object must take into account any table devices installed on the table end rail. If there are any devices installed on the table foot end, the width of these devices must be added to the existing 500 mm (19.7 in) to maintain absolute minimum distance of 500 mm (19.7 in).

Figure 28 Omega Table side clearance (CPR access)

All dimensions are in mm (inches)

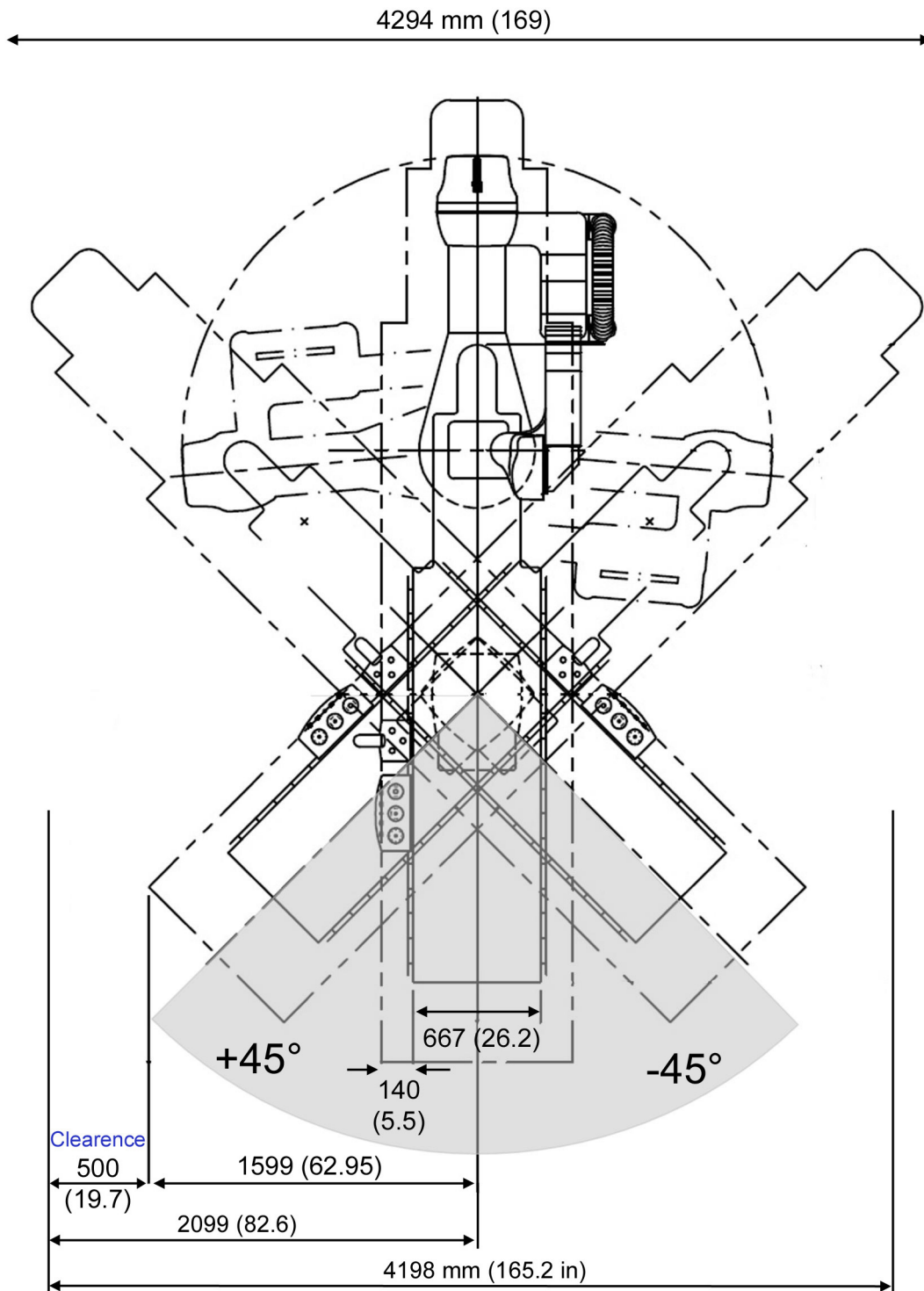

Figure 29 Table Head Extender dimensions

All measurements are in mm (inches)
Based on drawing 5262690ADW

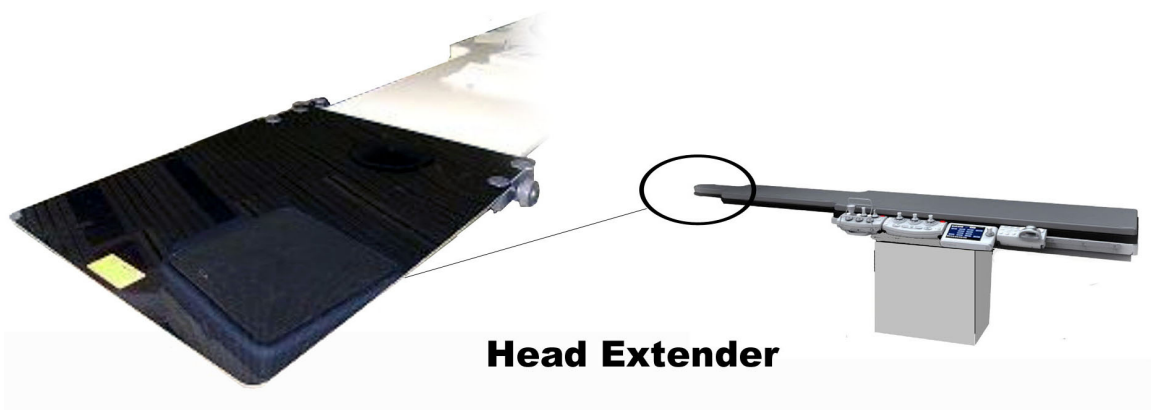
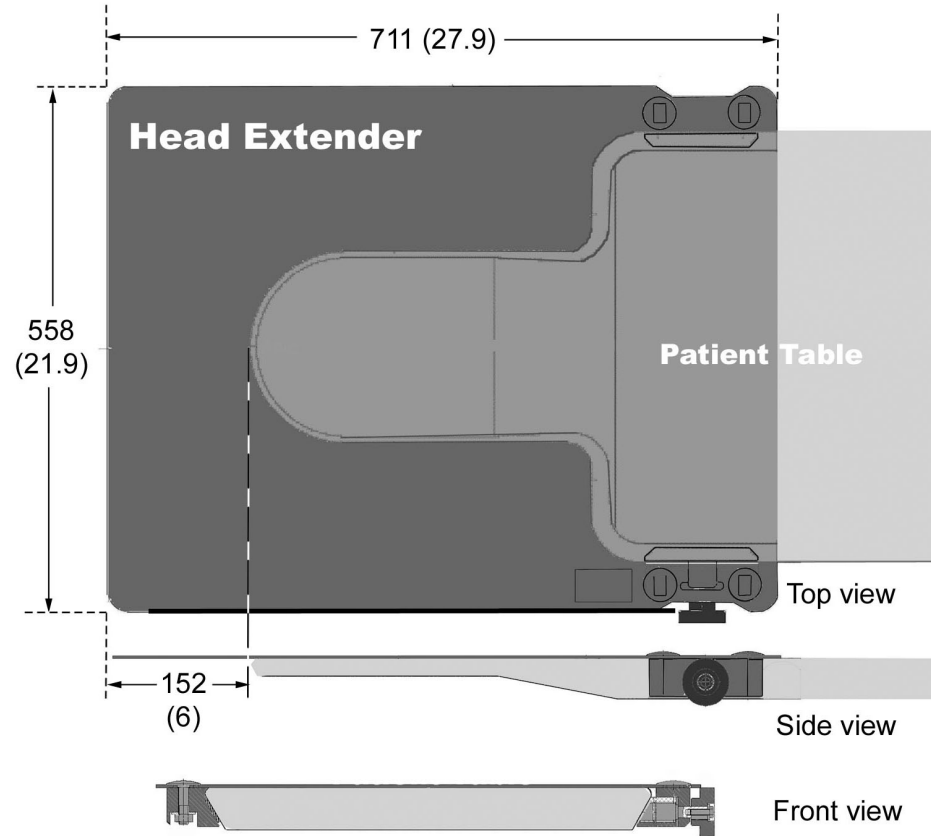

Figure 30 Gas box outlets Omega Table

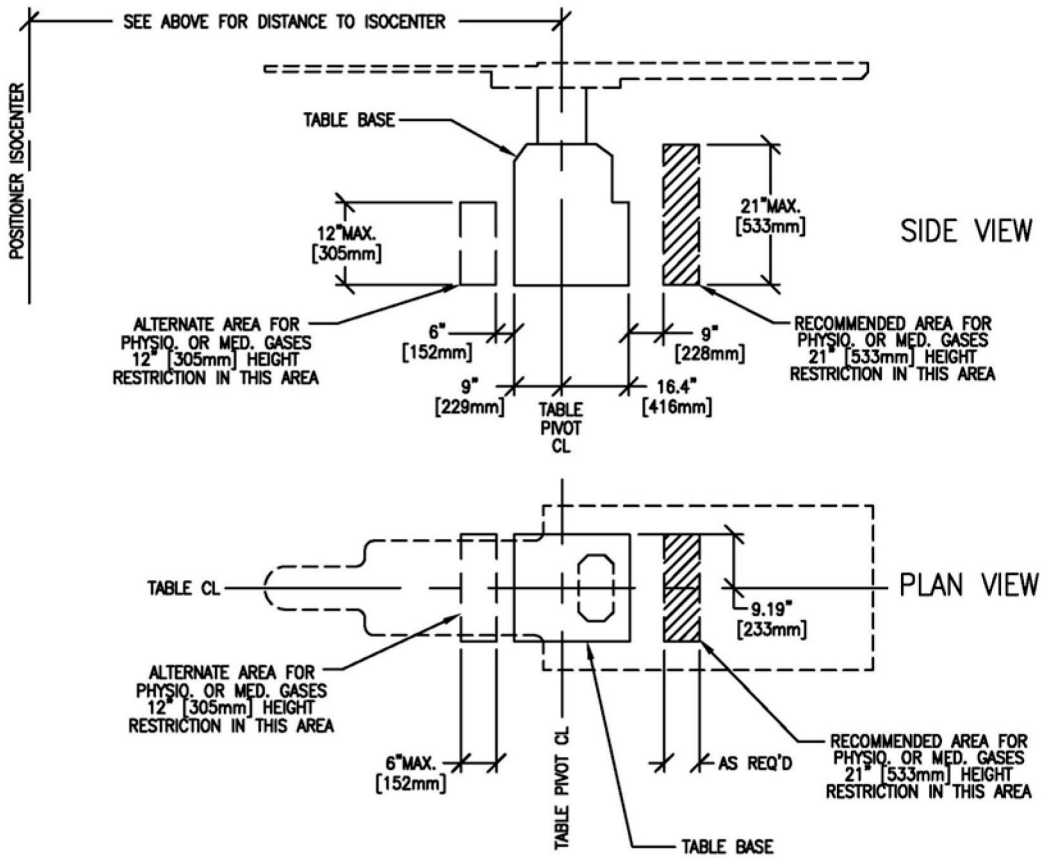
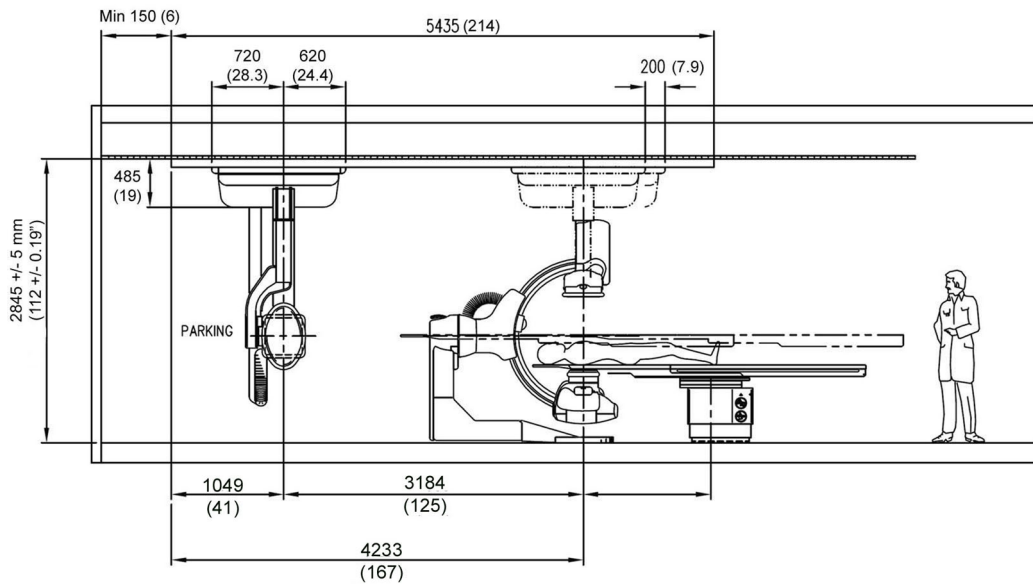
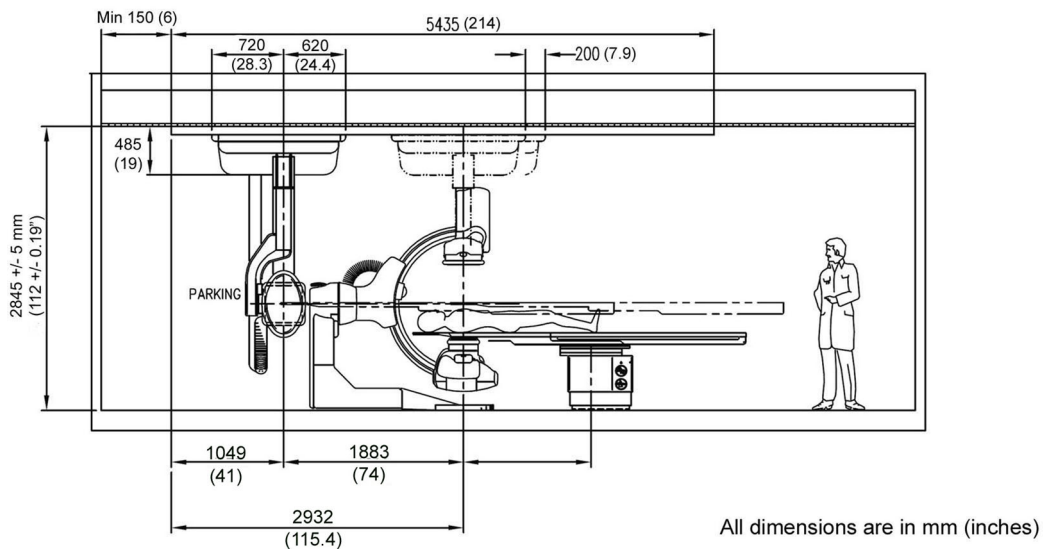

Figure 31 Frontal and Lateral Positioner and Omega Patient Table Relative Positions - Side View

Recommended and max parking position distance



Min parking position distance



NOTE

- (1) For Frontal Gantry isocenter to Table distance, refer to [Table 10 on page 50](#).
- (2) in the case of Lateral Gantry Off iso feature installed, the Lateral Gantry will work in the range - 200 mm (7.9 in) and 200 mm (7.9 in) from isocenter.
- (3) Lateral Gantry parking not allowed at patient foot end.

Figure 32 Frontal and Lateral Positioner and Omega Patient Table Relative Positions - Top View

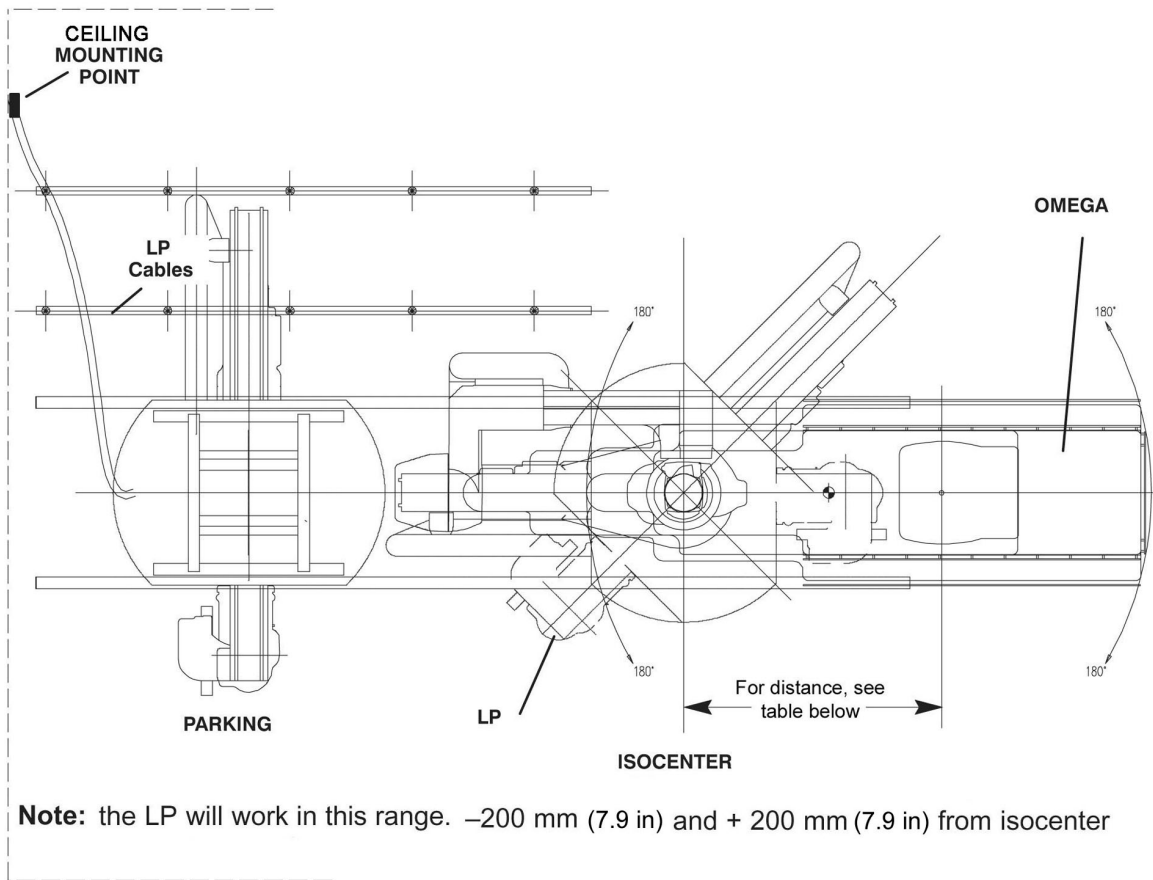
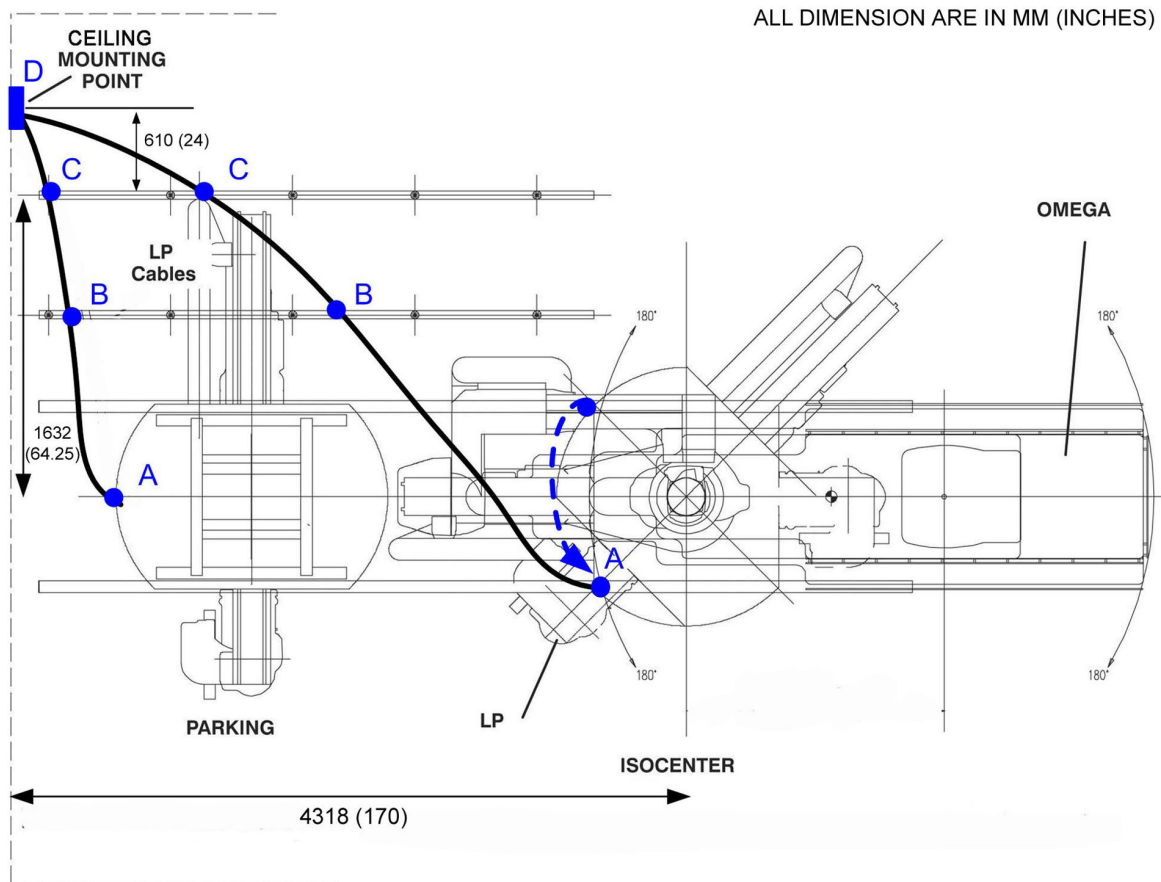

Table 10 Patient Table - Frontal Gantry isocenter distances

	ANGIO / CARDIO	CARDIO / NEURO
Omega V - non motorized	1278 mm (50.3 in)	1395 mm (54.9 in)
Omega V - motorized	1278 mm (50.3 in)	1395 mm (54.9 in)

Figure 33 Lateral Positioner Cable Drape Length



Maximum cable drape length is 6 m / 236 in (with vinyl zipper cable cover of 6.2 m / 244 in) from Lateral Gantry to ceiling exit point. This includes sag between drape points (A, B, C and D).

The worst case Lateral Gantry cable drape extension, including sag, is:

- 1.85 m (72.8 in) between A and B
- 2.05 m (80.7 in) between B and C
- 2.30 m (90.5 in) between C and D

Figure 34 LCD 6 monitors suspension dimensions (Optional)

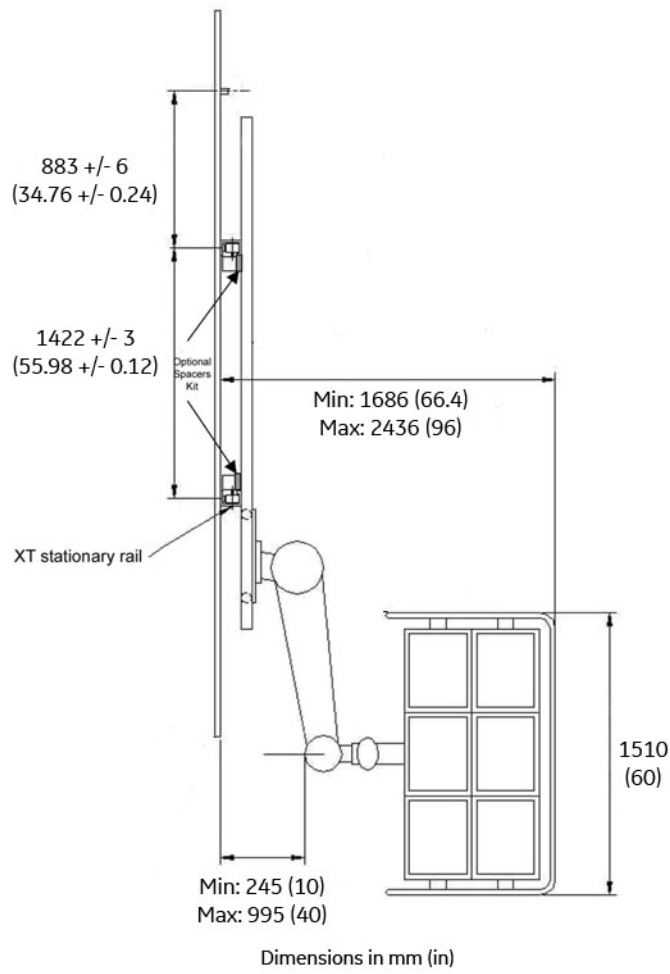

Figure 35 Large Display suspension with rails dimensions (Optional)

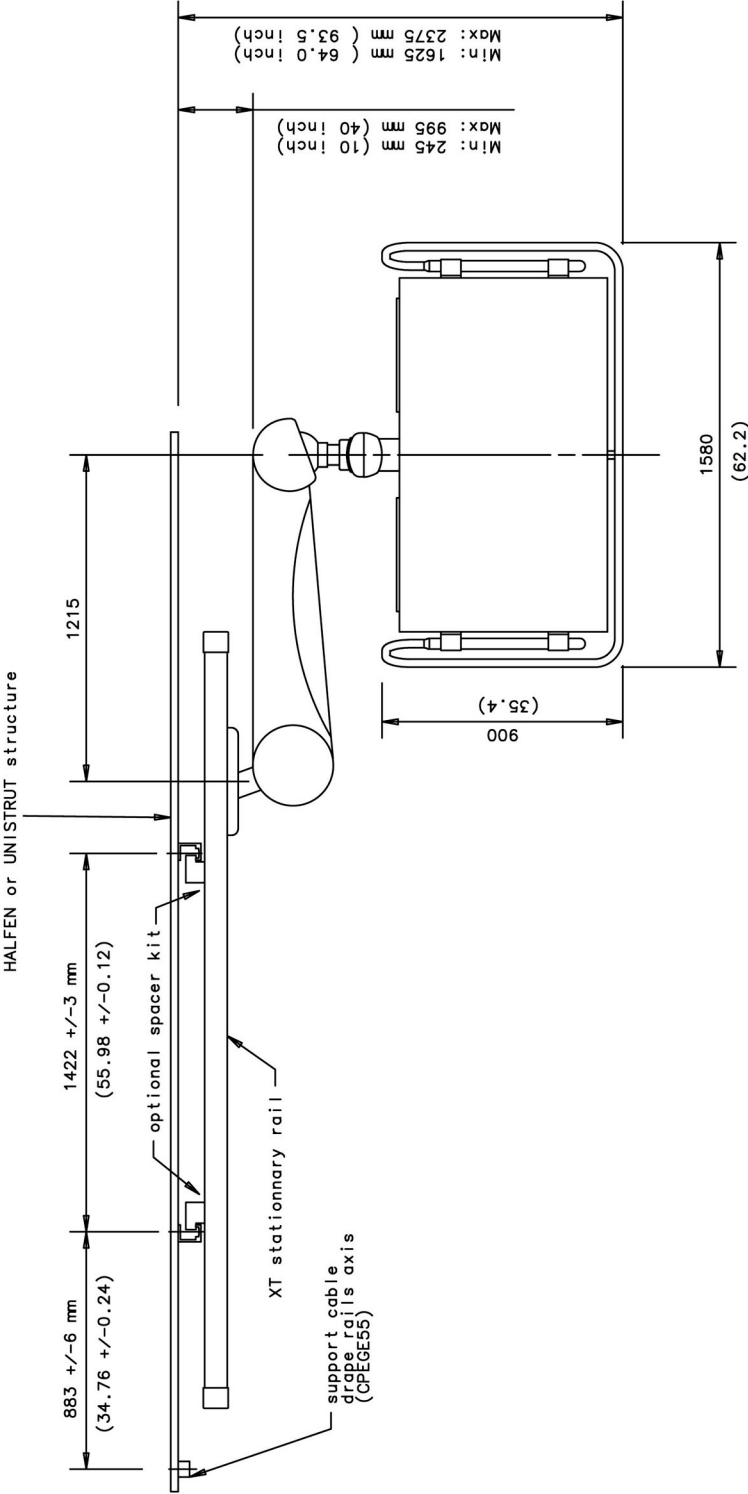

Figure 36 Large display Mavig suspension with fixed point dual arm dimensions (Optional)

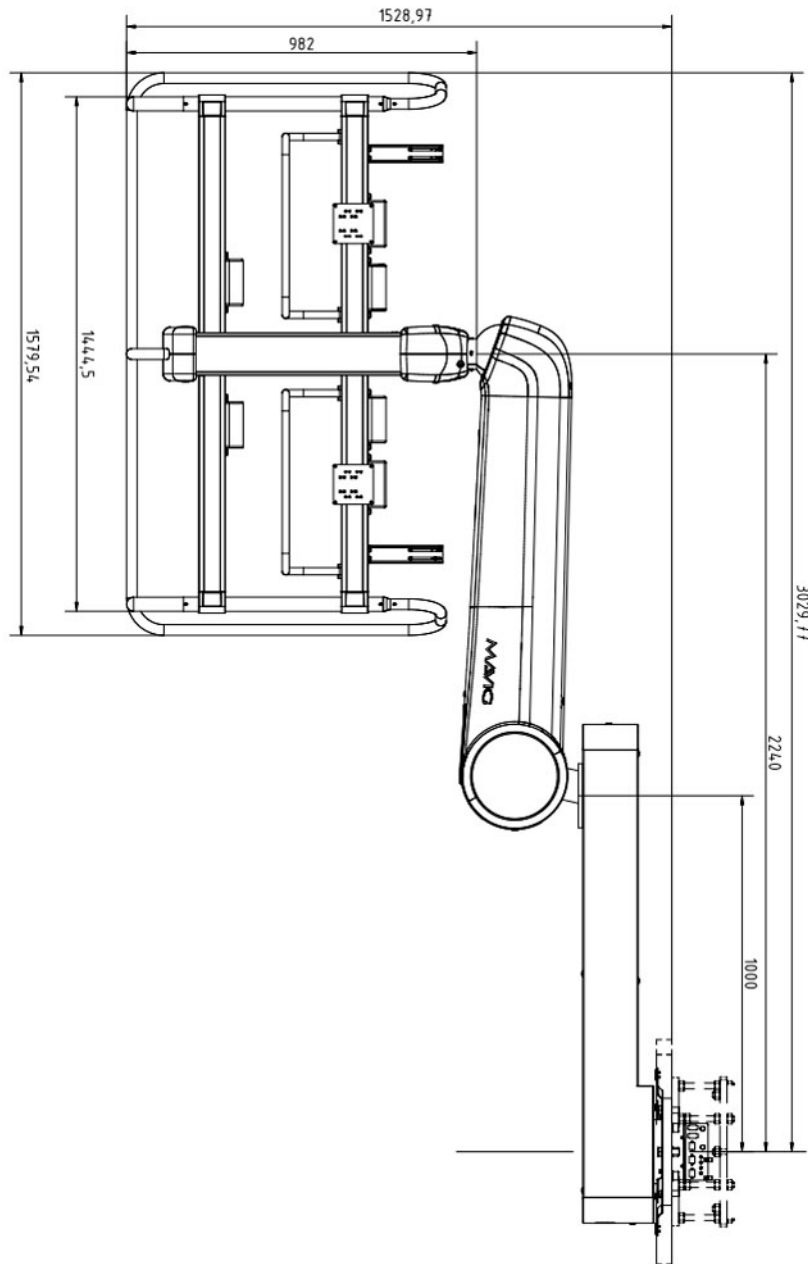

Figure 38 C2 Cabinet dimensions

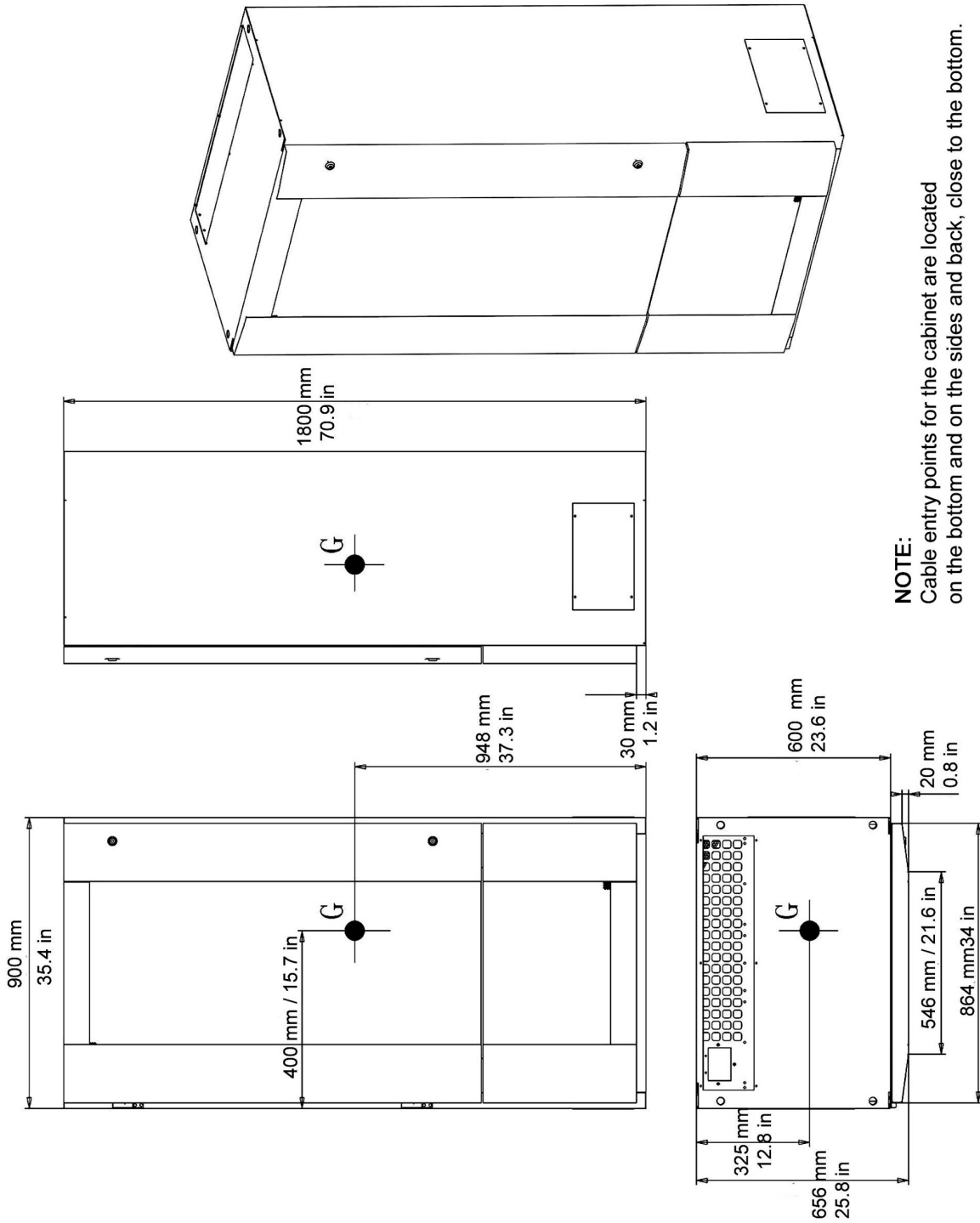
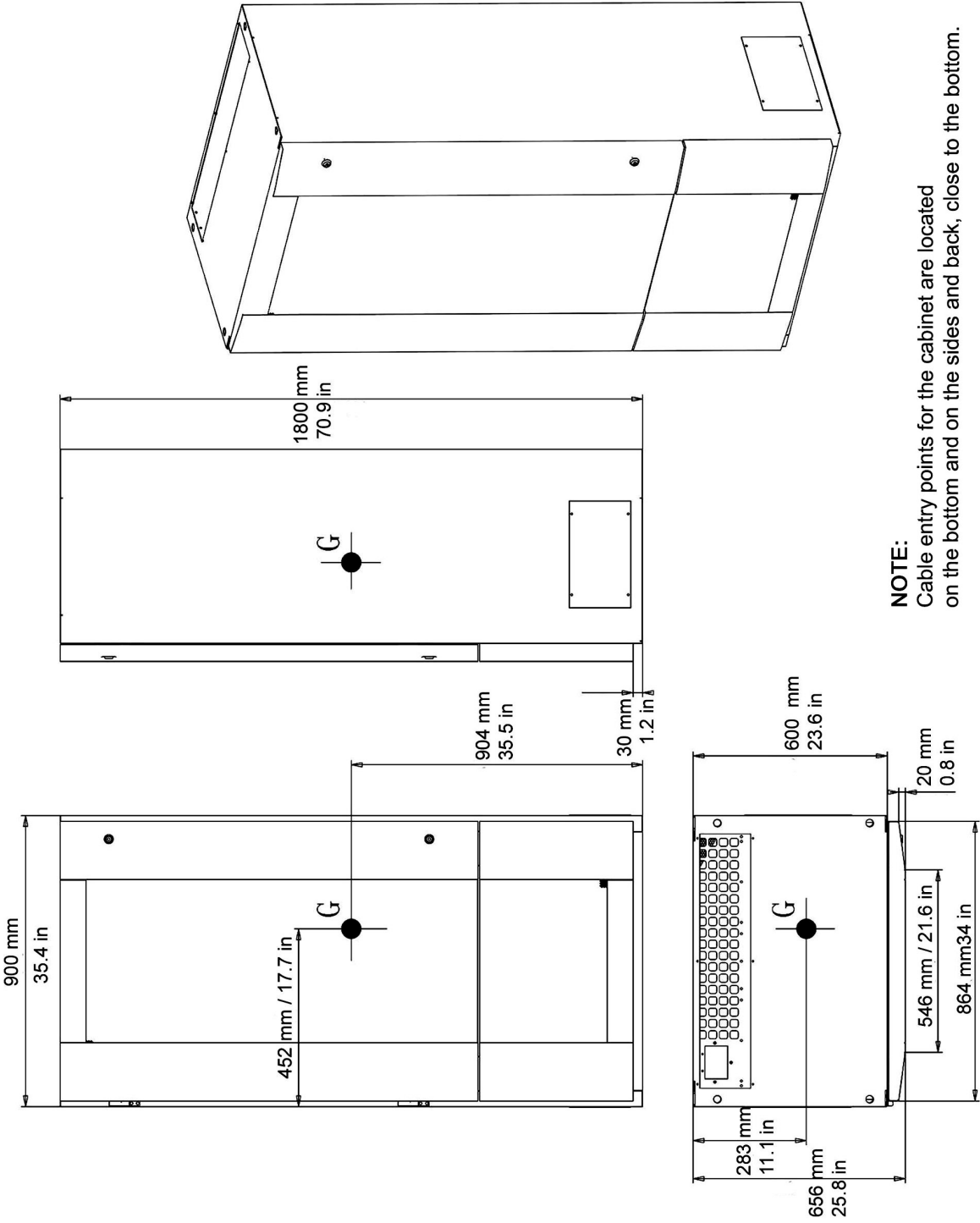

Figure 39 C1 Frontal Cabinet dimensions



NOTE: Cable entry points for the cabinet are located on the bottom and on the sides and back, close to the bottom.

Figure 40 C1 Lateral Cabinet dimensions

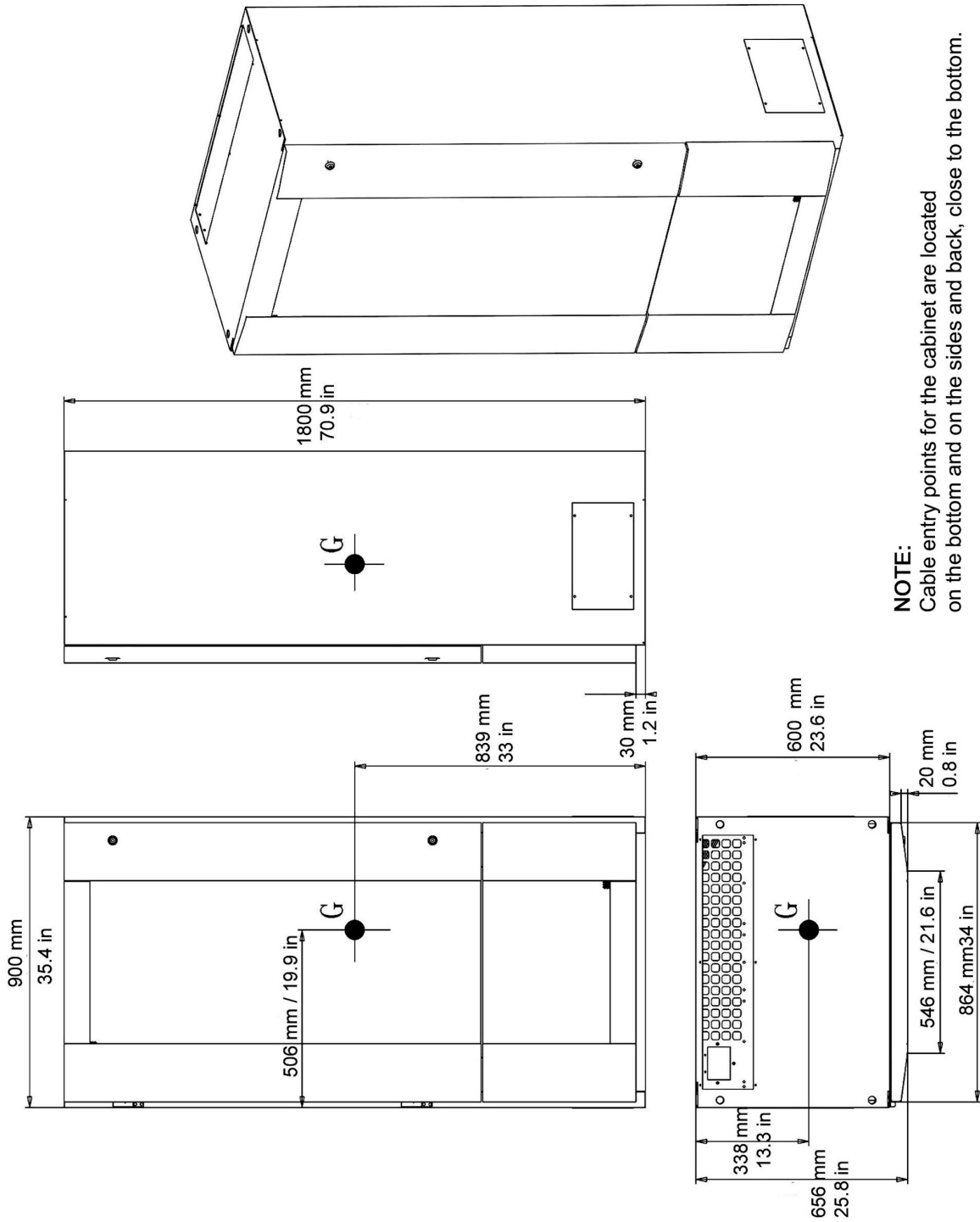
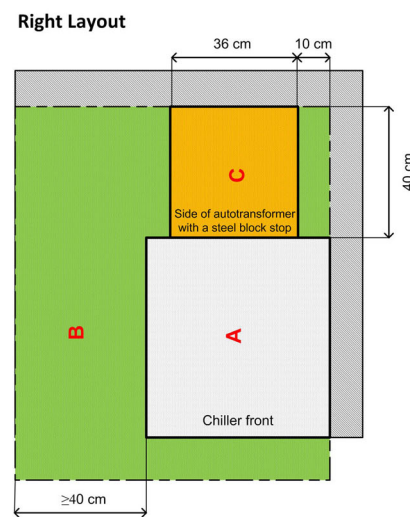
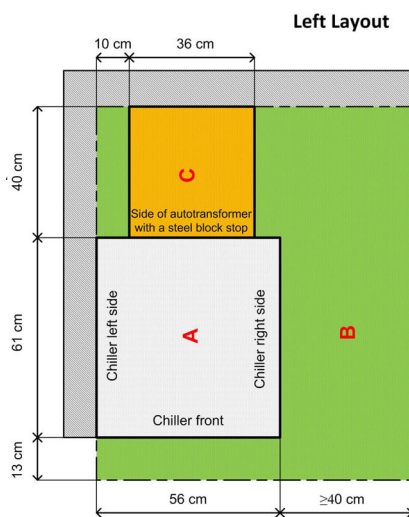

Figure 41 X-Ray Tube Chiller dimensions

ALL DIMENSION IN CM (INCHES)



NOTE

Required floor space depends on ambient room temperatures. When in doubt, allow for maximum floor space.

Figure 42 Detector Conditioner dimensions

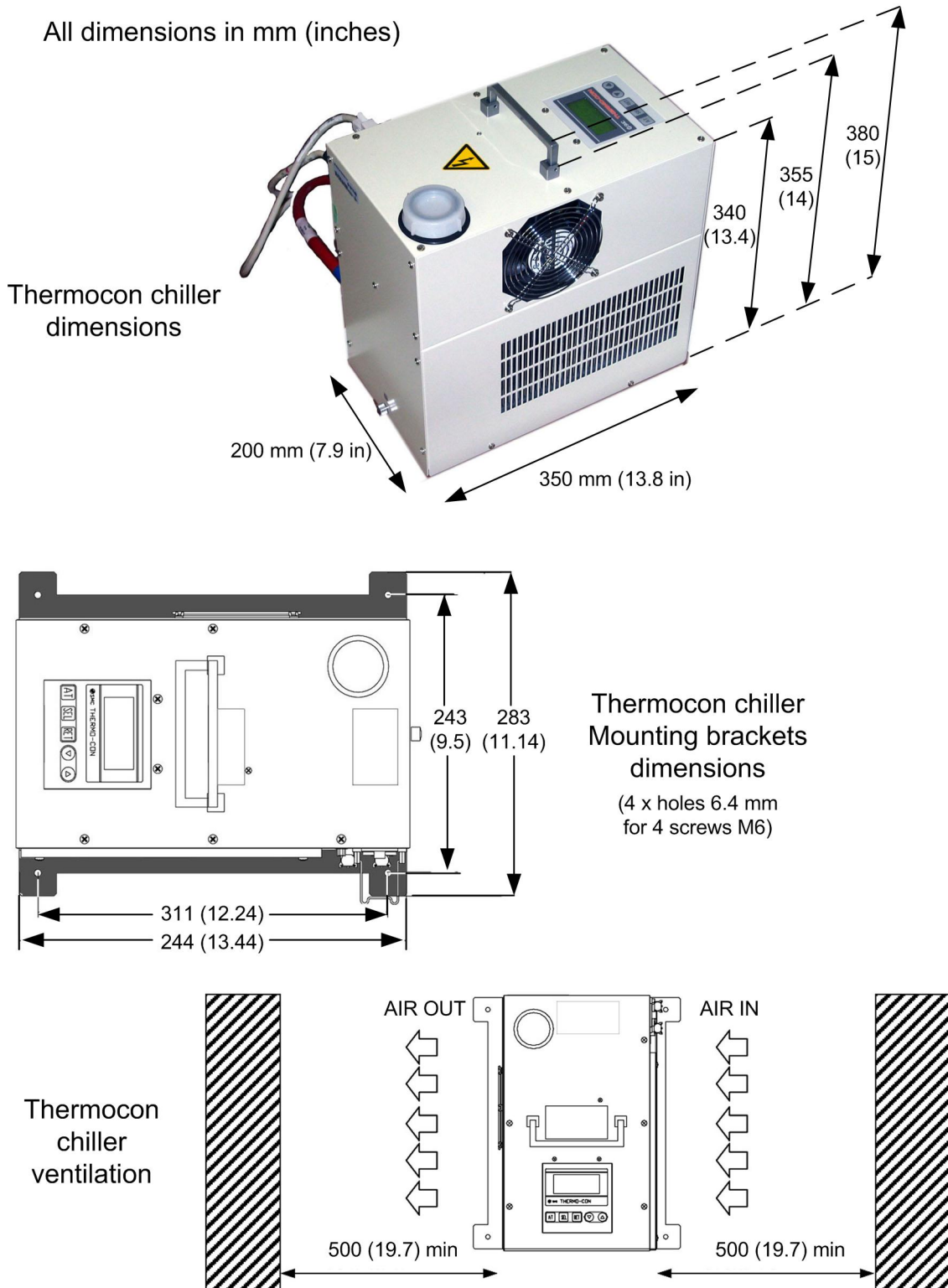

Figure 43 1 kVA Cabinet UPS (model 9130) dimensions



Figure 44 3 kVA LDM UPS (model 9130) dimensions



Figure 45 Fluoro UPS UL dimensions (Optional)

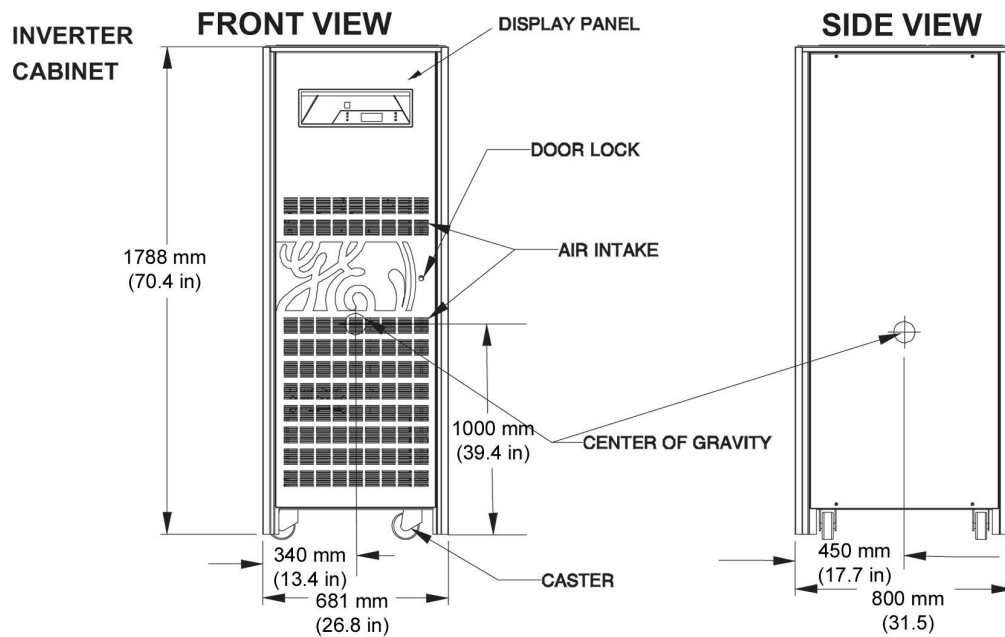

The left, right or back side of the UPS cabinet can be positioned against the wall.

The front side of the UPS cabinet must be accessible for maintenance operation.

In front of the cabinet, the clear width of the service area to insure electrical safety shall be at least 0.9 m. In cases where 2 cabinets are installed face to face (both sides of the access way), the clear width shall be at least 1.2 m.

Recommended minimum clearance between ceiling and top of the UPS should be 400 mm (16") for proper cooling air exhaust.

Figure 46 Fluoro UPS CE dimensions (Optional)

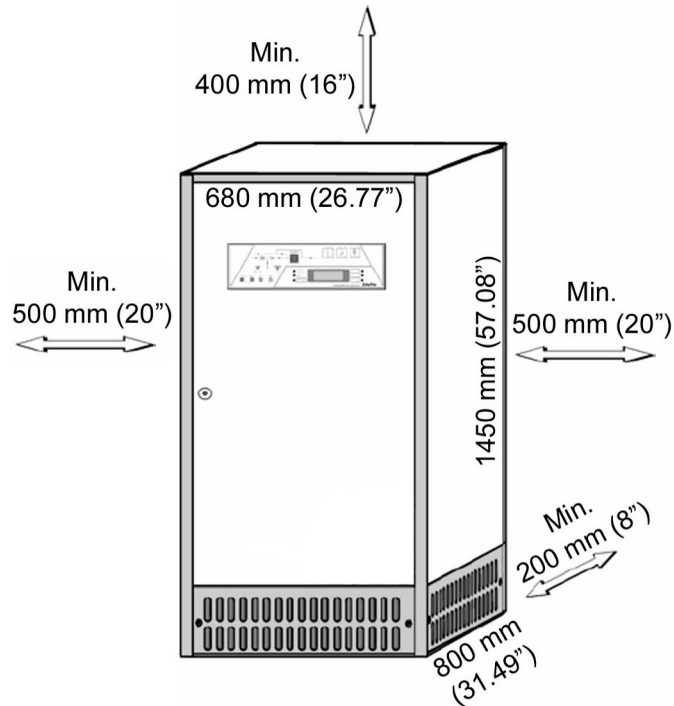

The UPS cabinet can be positioned against the wall but, in order to improve the ventilation and to make easier the maintenance operations for UPS and battery, we recommend a minimum distance of 200 mm (8") from the wall.

For maintenance operations, a minimum clearance distance of 500 mm (20") is required for both left and right sides of the UPS cabinet.

In front of the cabinet, the clear width of the service area to insure electrical safety shall be at least 0.9 m. In cases where 2 cabinets are installed face to face (both sides of the access way), the clear width shall be at least 1.2 m.

Recommended minimum clearance between ceiling and top of the UPS should be 400 mm (16") for proper cooling air exhaust.

NOTE

A minimum distance of 2 m (79 in) between X-Ray tube Chiller and Fluoro UPS CE cabinet is required.

NOTE

A Fire extinguisher (non-water type, ex. CO2) shall be provided and installed by the customer close to the Fluoro UPS CE cabinet.

Figure 47 ECG Acquisition Device Modules dimensions

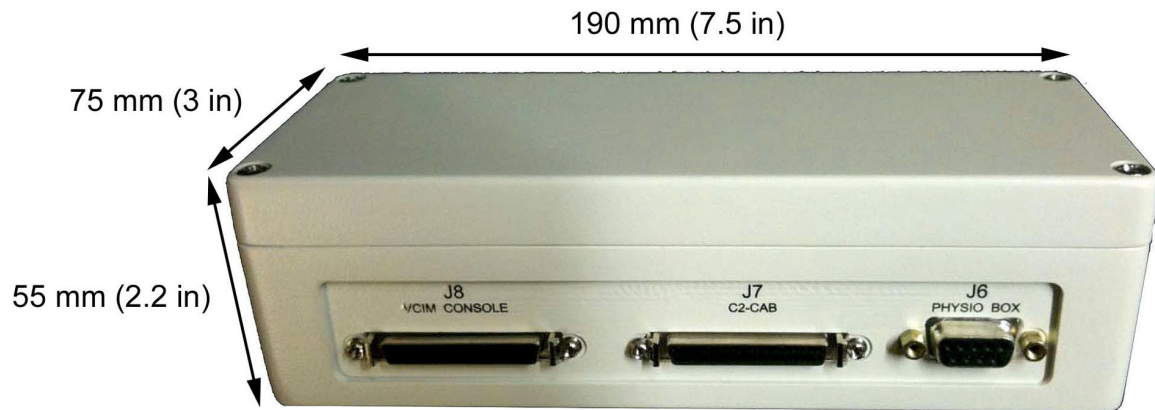

Hubican Module

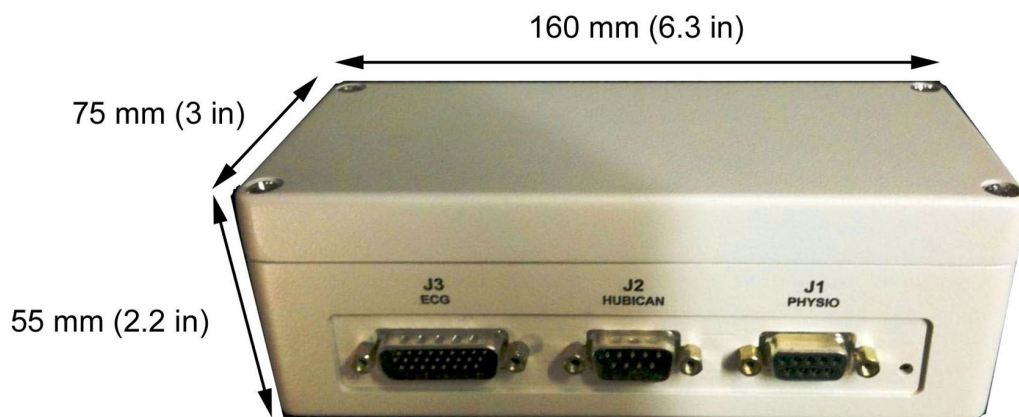

Physio Module

Figure 48 Large Display Cabinet dimensions (Optional)

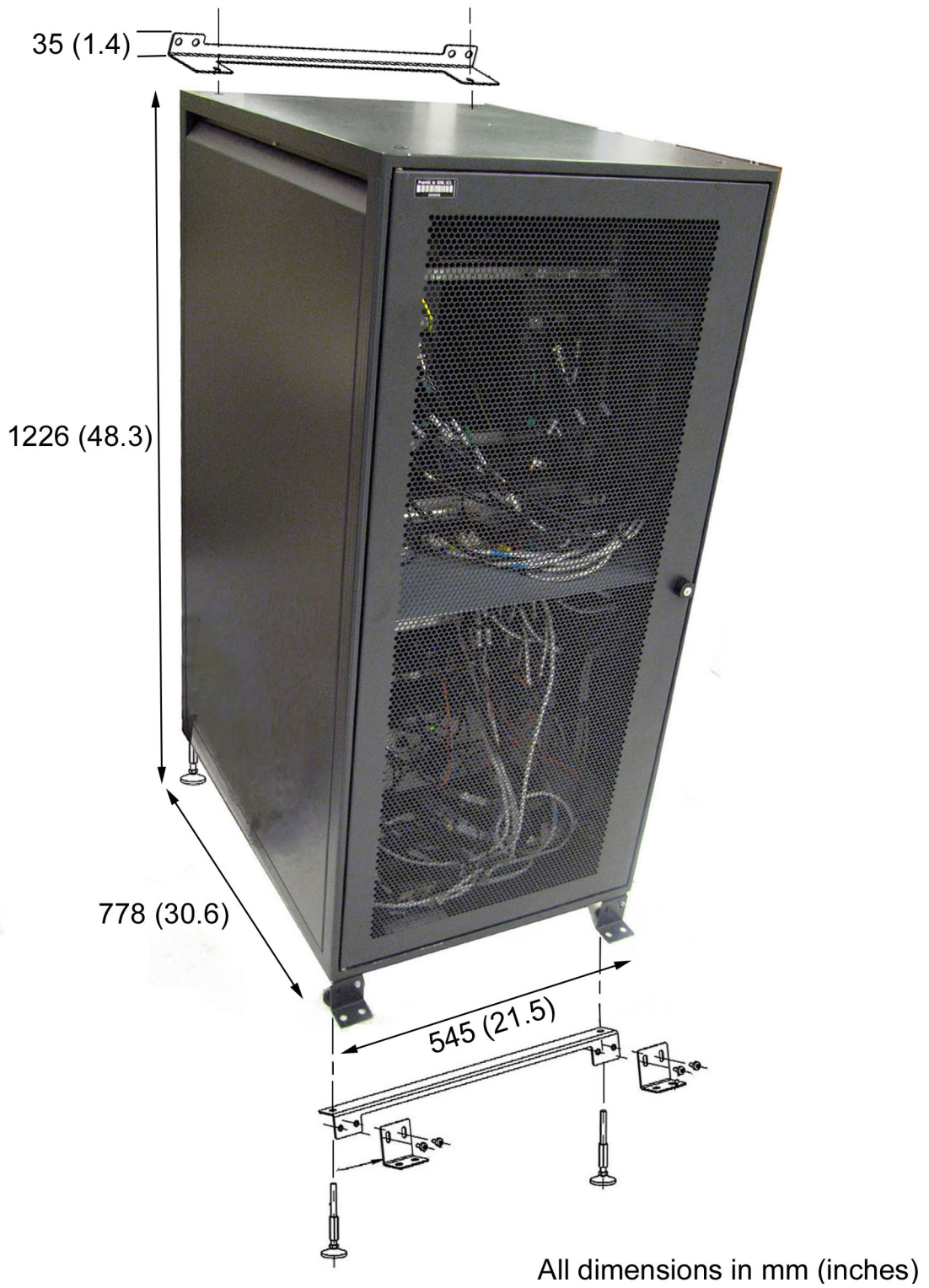

Figure 49 DL Keypad dimensions

ALL DIMENSIONS ARE IN MM (INCHES)

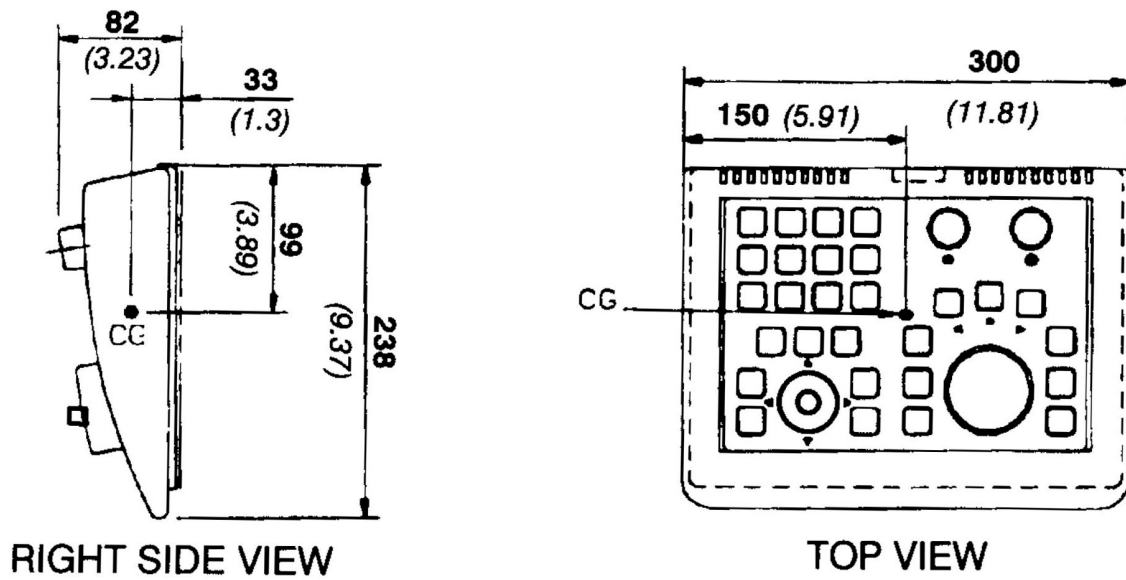

Figure 50 DL Image Monitor dimensions

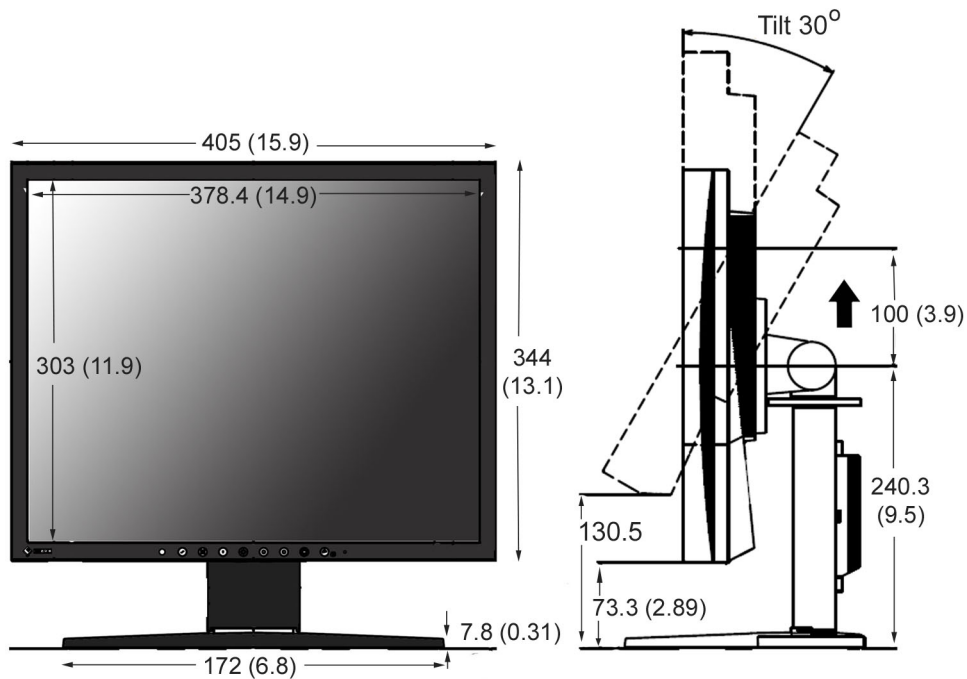

Figure 51 VCIM dimensions



2.1.4 Monitor and Monitor Suspension References

2.1.4.1 System Compatibility Cross-Reference - Monitor Support & Suspension

PRODUCT NAME	MODEL NUMBER	PRE-INSTALLATION DOCUMENT NUMBER	CATALOG NUMBER
PRECABLED LCD 6 MONITOR SUSPENSION: • CABLE HARNESS 24 m • or CABLE HARNESS 36 m	5520086 • 5420085 • or 5420087	2393190-1-1EN	
THIRD PARTY MONITOR SUSPENSION • CABLE HARNESS 24M • or CABLE HARNESS 36M • or LDM power and video cables for third party monitor suspension	Non-GE supplied • 5420085 • or 5420087 • or 5449713	See manufacturer's documentation 5772390-1EN	

(continued)			
PRODUCT NAME	MODEL NUMBER	PRE-INSTALLATION DOCUMENT NUMBER	CATALOG NUMBER
LARGE DISPLAY SUSPENSION <ul style="list-style-type: none"> • HARNESS 36 m for LARGE DISPLAY SUSPENSION • Handle of LDM suspension 	5410519 <ul style="list-style-type: none"> • 5410521 • 5415439 	5422757-3-1EN	
LDM SUSPENSION WITH FIXED POINT DUAL ARM <ul style="list-style-type: none"> • MAVIG SUSPENSION WITH FIXED POINT DUAL ARM FOR LARGE DISPLAY MONITOR • MAVIG suspension with fixed point dual arm for Large Display Monitor - External Cables - CIEE 	<ul style="list-style-type: none"> • 5735831 • 5747500 	MAVIG Assembly Instructions - Ceiling Substructure : DBF0100X (where X may be 1 or higher)	

2.1.4.2 System Compatibilities Cross-Reference - 19" Monitors

PRODUCT NAME	MODEL NUMBER	PRE-INSTALLATION DOCUMENT NUMBER	CATALOG NUMBER
LCD 19" - SMD19100G B&W with Stand	5148721-2	5219983-100	
LCD 19" - SMD19100G B&W without Stand	5148721-3		
LCD 19" - SMD19100G Color with Stand	5148720-2		
LCD 19" - SMD19100G Color without Stand	5148720-3		
Eizo 19" LCD HB color monitor RX150 GE		5499528-1-8EN	

2.1.5 System Compatibility

2.1.5.1 System Compatibility Cross-Reference – Monitor Support & Suspension Sub-System

Product Name	Pre-Installation Document Number	Catalog Number
Pre-cabled LCD 6 Monitor Suspension	2393190-1-1EN	

2.1.5.2 System Compatibilities Cross-Reference – 19” LCD Monitors Sub-System

Product Name	Pre-Installation Document Number	Catalog Number
LCD 19” EIZO MX193 Color Monitor	provided by EIZO	
Eizo 19” LCD HB color monitor RX150 GE	sm 5499528-1-8EN	

2.2 Room Layouts

2.2.1 Room Dimension Requirements

For Room size dimensions, refer to [2.2.2.1 Patient Room Layout on page 70](#).

For additional details, refer to [2.2.3 Room Layout Considerations on page 78](#).

2.2.2 Room Layout Drawings

2.2.2.1 Patient Room Layout



LOCATION IN TECHNICAL ROOM FOR ELECTRICAL CABINETS IS MANDATORY. THE ELECTRONIC CABINETS (C1, C2, OPTIONAL LD CABINET, COOLIX 4100 CHILLER, DETECTOR CONDITIONER AND FLUORO UPS WHEN INSTALLED) INCLUDE FANS THAT ARE CREATING AIR-CIRCULATION OF PULSED-AIR. WHEN THIS PULSED AIR IS IN AN ENVIRONMENT THAT MAY CONTAIN AIRBORNE PATHOGENS LIKE AN EXAM ROOM/CONTROL ROOM, THERE IS A RISK OF TRANSMISSION OF THESE AIRBORNE PATHOGENS FROM PATIENTS TO OTHER PATIENTS OR CLINICAL PERSONNEL (NOSOCOMIAL DISEASES).

TO REDUCE THIS RISK, THE ELECTRONIC CABINETS MUST BE INSTALLED IN A ROOM SEPARATED FROM EXAM ROOM/CONTROL ROOM, I.E., TECHNICAL ROOM.

Table 11 Exam room dimensions

Room Dimensions	Length x Width	Ceiling Height
Recommended:	11570 mm x 8000 mm (38 ft 0 in x 26 ft 2 in)	2845 mm ± 5 mm (9 ft 4 in ± 0.2 in) is mandatory ceiling height
Minimum:	6900 mm x 4400 mm (22 ft 8 in x 14 ft 5 in)	

NOTE

The values above are calculated with the table without accessories, such as the **Table Head extender**. For details of Head Extender dimensions, see [2.1.3 Dimension Drawings on page 37](#)

Table 12 (For Suspension with rails) Room Layout components (see Illustration below):

1		Lateral Gantry stationary rails
2		Cable drape rail
3	Lateral Gantry	Lateral Gantry
4	LC	Frontal Gantry
5		Monitor suspension
6		Counter balanced eye or thyroid shield
7	TBL	Omega table
8		Customer supplied storage cabinet
9		XT Stationary Rails

NOTE

The Network drop outlet must be located less than 1 meter (3 feet) from the C1 Frontal Cabinet.

Figure 52 (For Suspension with rails) Patient Room Layout for Innova System

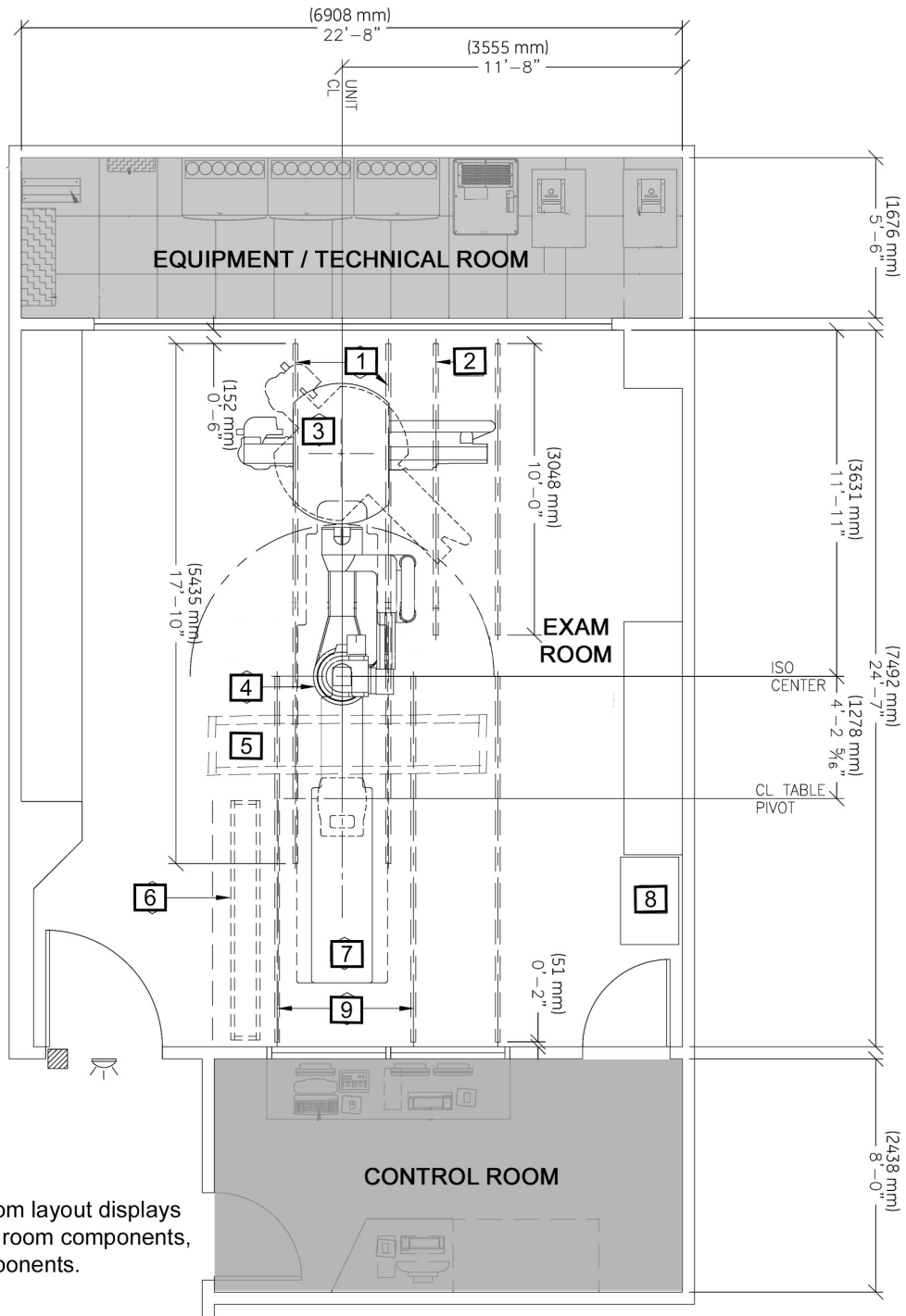

NOTE: This room layout displays mandatory test room components, but not all components.

Table 13 (For LDM Suspension with fixed point Dual Arm) Room Layout components (see Illustration below)

Item	DESCRIPTION	DIMENSIONS LxWxH (mm)	WEIGHT (kg)
1	LC GANTRY	1552x1070x2234	750
2	LP GANTRY	4135x2724x2112	735/797
3	OMEGA V LONG PATIENT TABLE	3336x727x780	590
4	MAVIG LDM SUSPENSION	-	248
5	XRAY BUZZER	-	1
6	MAVIG RAD SHIELD AND LAMP WITH 2.5M CEILING TRACK	-	93

Figure 53 (For LDM Suspension with fixed point Dual Arm) Top view of MAVIG suspension with fixed point with dual arm

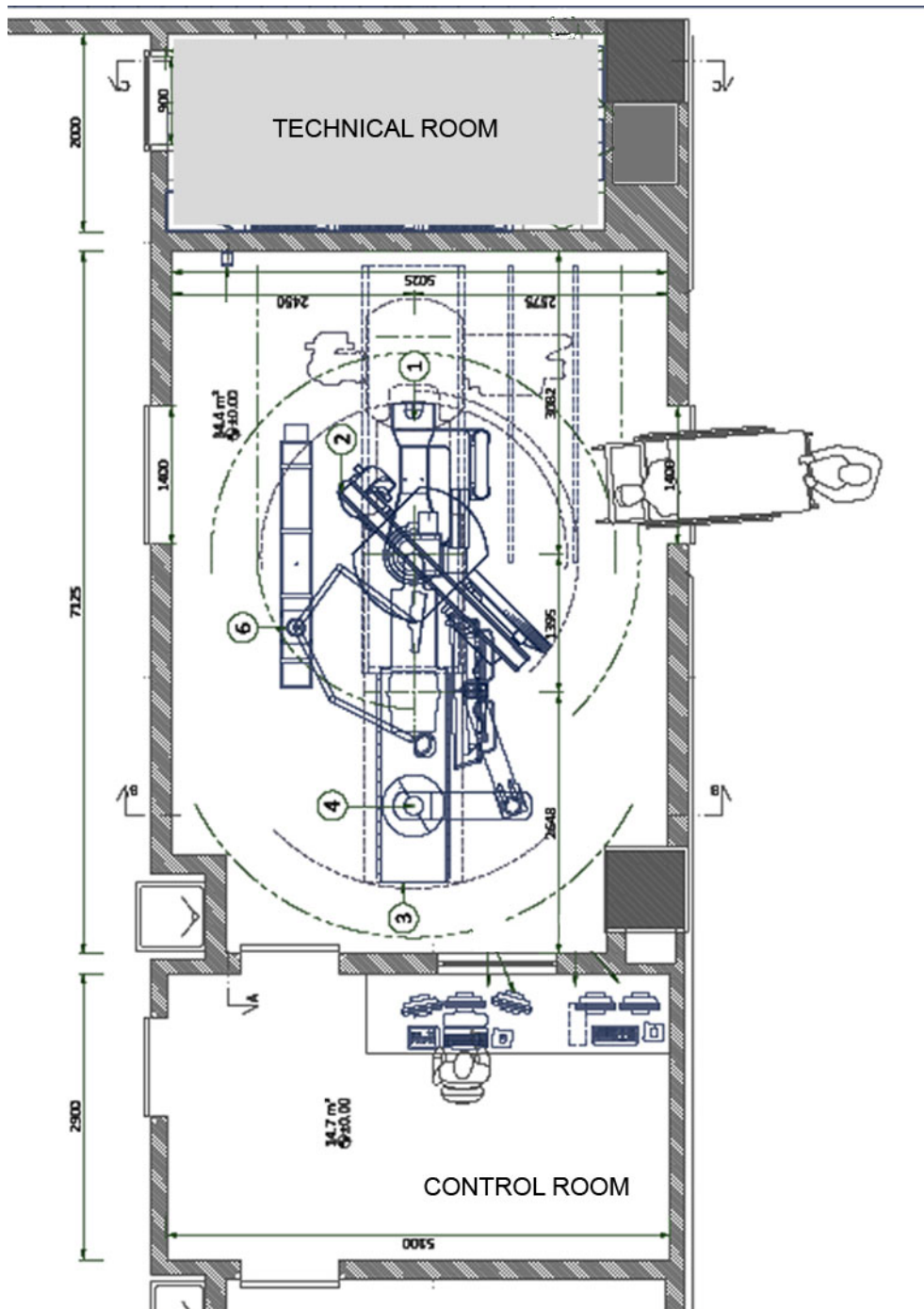

NOTE

The suspension ceiling fixation shall be determined taking into account at least:

- Clinical need: with an overall radius coverage of 2.03 m, ensure the monitor will be able to reach the position required by medical staff,
- Parking position,
- Ceiling constraints: other component and air flow,
- Cable output and ceiling trap.

2.2.2.2 Technical Room Layout

For the service access and ventilation restraint dimensions below, see [2.1.3 Dimension Drawings on page 37](#) and [2.2.3 Room Layout Considerations on page 78](#).

Figure 54

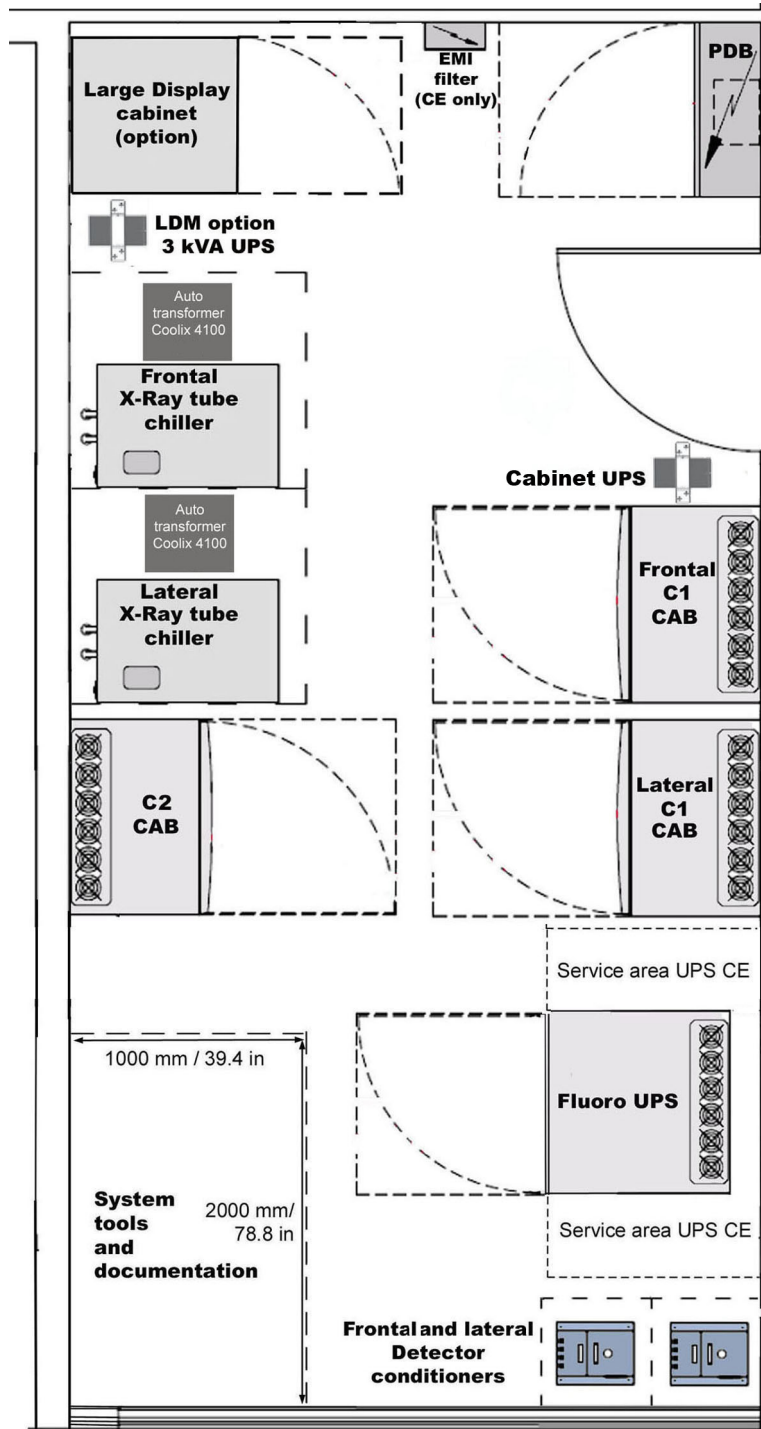

2.2.2.3 ECG Device Room Configurations

The hardware delivered with the ECG acquisition kit will need to be installed in the Control Room and in Exam Room depending on the type of ECG Device used on the site.

The ECG Device/Room configurations need to be checked as this can impact ON the way parts and cables can be installed.

Basically, there will be two different Installation Configurations depending on the type of ECG device to connect to the Innova system:

2.2.2.3.1 Installation Configuration #1:

For ECG devices installed in Control Room (such as GE ECG like MacLab, CardioLab or ComboLab)

Both the Physio & Hubican modules are installed in the Control Room as shown below:

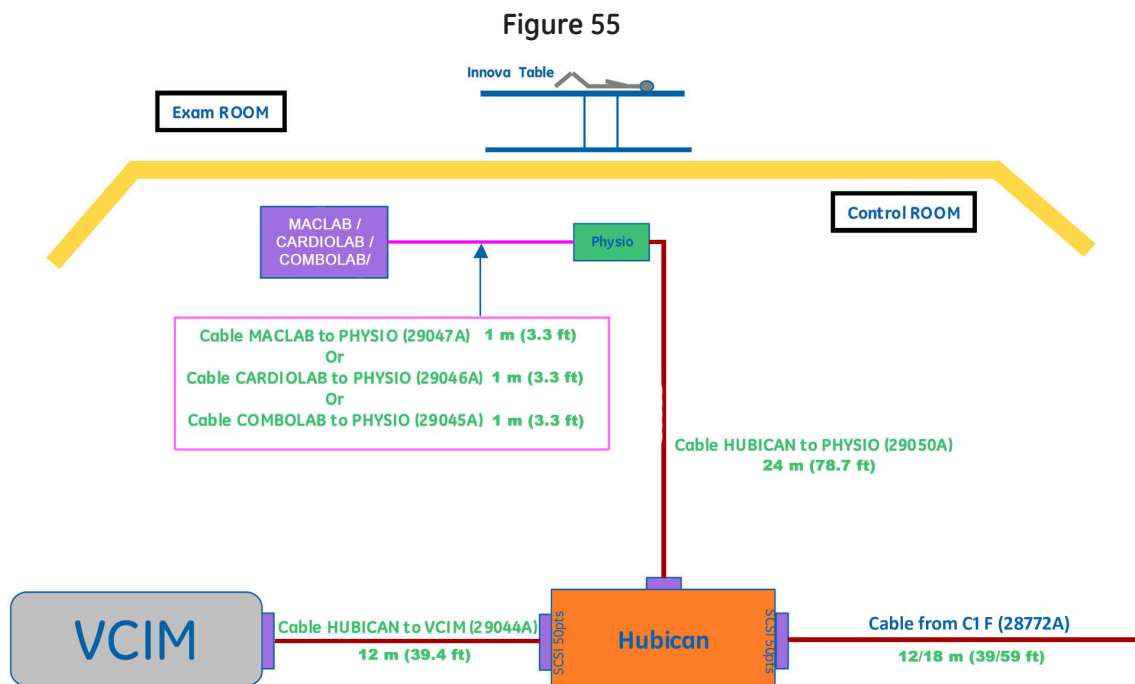

2.2.2.3.2 Installation Configuration #2:

For ECG devices installed in Exam Room (ECG device from the competitor)

Physio and/or Hubican modules will be installed in Exam Room as shown below:

Figure 56

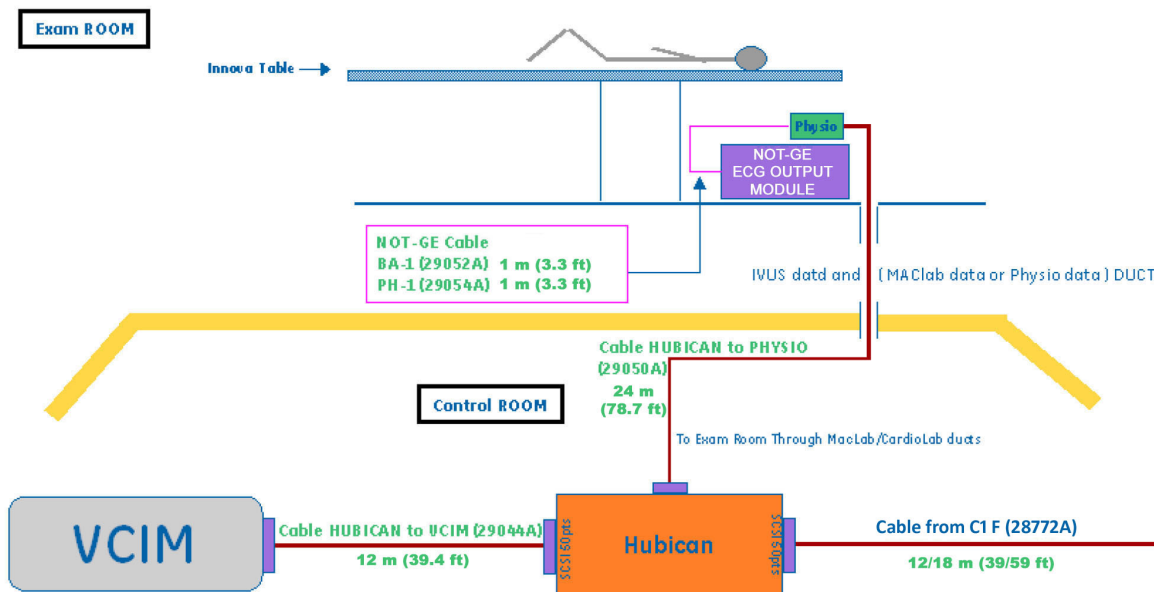

2.2.3 Room Layout Considerations

2.2.3.1 Service Access

Allow appropriate space for service access of equipment. Consult component pre-installation directions for clearance information.

2.2.3.2 Clinical Access

Make sure that you plan the room with the following clinical access requirements:

- Provide easy access to the patient table. Stretchers and other mobile hospital equipment must reach the table quickly.
- Gantries installation shall make a provision so that the clearance is 500 mm (19.7in) around the Frontal and Lateral Gantries.
- The layout of the table in the room shall make a provision so that clearance between maximum table position (head side) and any object in the room (e.g. wall, device) be superior to 500 mm (19.68 in) (650 mm (25.5 in) if Head Extender is used).
- Provide sufficient space around the patient table for the unimpeded conduct of CPR (Cardiac Pulmonary Resuscitation). With the table in this position, the table must be capable of rotating +/- 45°.
- Clinicians at the patient table must be able to communicate with assistants in the control area.
- There must be an unrestricted view of the video monitors and physiological monitoring equipment from the vascular table.

- Operators in the control area must have easy access to the control console. However, position the controls (including handswitches) so that the operator cannot take exposures while looking around or standing outside the control booth's lead glass window.
- Operators in the control area must have easy access to video recorders and injector programmers, film and video storage cabinets, and service and operating manuals.
- Consult customer on the number and location of nonelectrical lines (air, oxygen, vacuum, water, etc.) in the vascular room.
- For Large Display systems, in case of failure of the main monitor, the clearance around the main monitor suspension must assure that it can be immediately be flipped at 180°, exposing the backup monitors.

2.2.3.3 Peripheral Equipment

Consult hospital personnel regarding additional space requirements for the following types of hospital equipment:

- Storage cabinets.
- Sinks.
- Oxygen stations.
- IV apparatus.
- Injectors.
- Heart monitoring equipment.
- Crash cart.

2.2.3.4 Emergency Stop

It is recommended to install, in an accessible location, an additional EPO button that allows the instantaneous switching off of all power from the System (EXCEPT THE INPUT CABLE OF THE CABINET UPS FOR CE CONFIGURATION WITHOUT FLUORO UPS), including UPS and Fluoro UPS outputs.

To remove input power from THE INPUT CABLE OF THE CABINET UPS (FOR CE CONFIGURATION WITHOUT FLUORO UPS), turn OFF the PDB main breaker

Protect the Emergency Stop from accidental actuation.

2.2.3.5 Patient Environment Equipment

The components that may be installed within patient vicinity need to be medical equipment ("patient vicinity is defined in the standardization as a space within the room 1.83 m (6 ft) beyond the perimeter of the examination table and extending vertically 2.29 m (7 ft, 6 in) above the floor."). For the Innova System, the equipment are:

- Table
- C-arm
- Monitors
- Injector

- In-room AW mouse

2.2.3.6 Preferred Cabinet locations

NOTE

This is applicable for all types of cabinets (including PDB).

The clear width of the service area in front of the cabinet doors to insure electrical safety shall be at least 0.9 m for all cabinets except the Large Display cabinet (1 meter is necessary for Large Display cabinet). In cases where 2 cabinets are installed face to face (both sides of the access way), the clear width shall be at least 1.2 m.

Figure 57

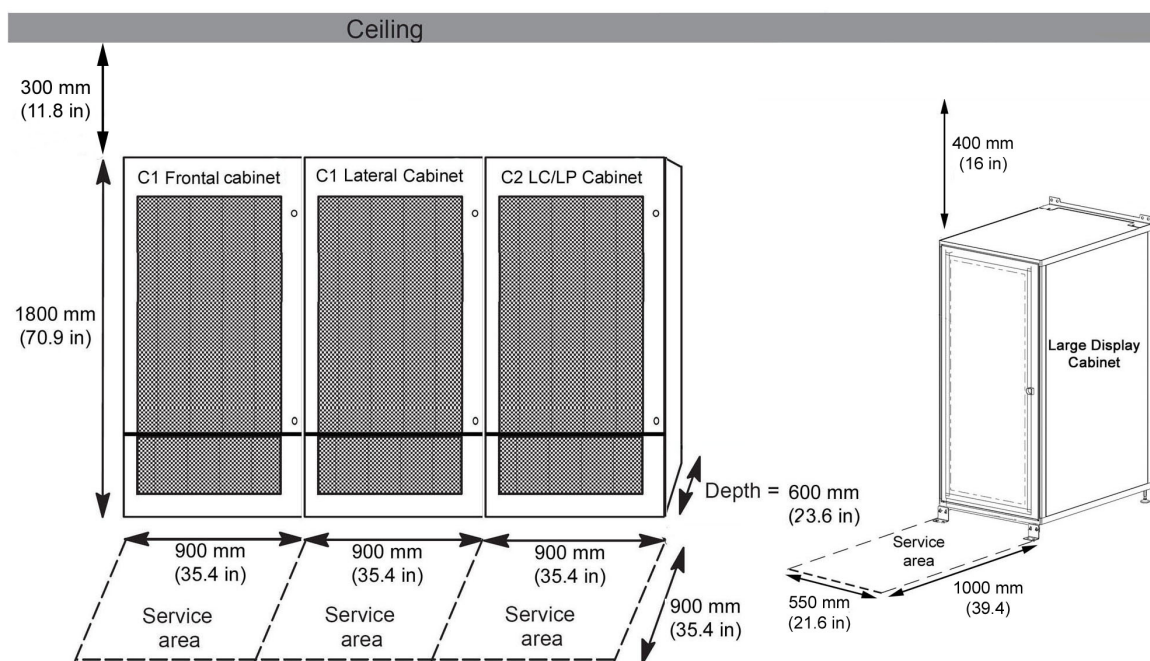

NOTE

The order of the cabinets above is C1 frontal, C1 lateral and C2 cabinets. This is just an example, cabinets can follow different orders.



The service area dimensions shown above are minimum requirements. Service areas must comply with local regulations if more stringent.

**NOTICE**

Specific configuration for Germany (DIN 6868-157 standard): LDM is installed, distance maximum between C1 Frontal Cabinet and LD Cabinet is 3 m.

2.2.3.7 Layout Constraints

Table 14 System Layout constraints Technical and Exam room on same floor

Location	Constraint Name	Parameter	Specification	Comment
Technical room	Cabinets location	Maximum relative distance	9 m (29 ft, 6 in)	Make sure to provide enough space for storing extra cable length (e.g. Plinth)
Technical room	Tube chillers location		The Tube Chiller shall be no more than 5 m (16 feet) above or 8 m (26 feet) below the upper position of the X-Ray Tube	
Technical room	Detector conditioner location		In tech room Max. 3 m (9 ft, 10 in) below Lateral Gantry rails	
Technical room	PDB location		In Tech Room	
Technical to Exam room	Distance between Frontal Gantry foot and C1 or C2 entry.	Relative distance	19.5 m (64 ft)	Tech and Exam room on same floor. 22 m (72 ft) for HV cables.
Technical to Exam room	Distance between Frontal Gantry foot and tube chiller	Relative distance	22 m (72 ft)	Tech and Exam room on same floor
Technical to Exam room	Distance between Frontal Gantry foot and Detector Conditioner	Relative distance	22 m (72 ft)	Tech and Exam room on same floor
Technical to Exam room	Distance between Lateral Gantry wall-box and C1 or C2 entry	Max relative distance (proj. on floor)	10.5 m (34 ft, 5 in)	Tech and Exam room on same floor
Technical to Exam room	Distance between Lateral Gantry wall-box and tube chiller	Max relative distance (proj. on floor)	11 m (36 ft, 1 in)	Tech and Exam room on same floor

System Layout constraints Technical and Exam room on same floor continued				
Location	Constraint Name	Parameter	Specification	Comment
Technical to Exam room	Distance between Lateral Gantry wall-box and Detector Conditioner	Max relative distance (proj. on floor)	19 m (62 ft, 4 in)	Tech and Exam room on same floor
Exam room	Minimum rail length past iso-centre towards foot end	Length	1.2 (3 ft 11 in)	In any case, Lateral Gantry parking is only possible at patient head

Table 15 Layout constraints Technical on above floor with respect to Exam room

Location	Constraint Name	Parameter	Specification	Comment
Technical room	Cabinets location	Maximum relative distance	9 m (29 ft, 6 in)	Make sure to provide enough space for storing extra cable length (e.g. Plinth)
Technical room	Tube chillers location		The Tube Chiller shall be no more than 5 m (16 feet) above or 8 m (26 feet) below the upper position of the X-Ray Tube (see Figure 58 on page 83)	
Technical room	Detector conditioner location		In tech room Max. 20 cm (7.9 in) above Lateral Gantry rails	
Technical room	PDB location		in Tech Room	
Technical to Exam room	Distance between Frontal Gantry and C1 or C2 entry.	Maximum relative distance	16.5 m (54 ft, 1 in)	Tech on floor above Exam room (assume Frontal Gantry foot to ceiling 3 m (9 ft, 10 in))
Technical to Exam room	Distance between Frontal Gantry foot and tube chiller	Relative distance	19 m (62 ft, 4 in)	Tech on floor above Exam room (assume Frontal Gantry foot to ceiling 3 m (9 ft, 10 in))
Technical to Exam room	Distance between Frontal Gantry foot and Detector Conditioner	Relative distance	19 m (62 ft, 4 in)	Tech on floor above Exam room (assume Frontal Gantry foot to ceiling 3 m (9 ft, 10 in))

Layout constraints Technical on above floor with respect to Exam room continued				
Location	Constraint Name	Parameter	Specification	Comment
Technical to Exam room	Distance between Lateral Gantry wall-box and C1 or C2 entry	Relative distance	13.5 m (44 ft, 3.5 in)	Tech on floor above Exam room
Technical to Exam room	Distance between Lateral Gantry wall-box and tube chiller	Maximum relative distance	14 m (45 ft, 11 in)	Tech on floor above Exam room
Technical to Exam room	Distance between Lateral Gantry wall-box and Detector Conditioner	Relative distance	22 m (72 ft, 2 in)	Tech on floor above Exam room
Exam room	minimum rail length past iso-centre towards foot end	Length	1.2 (3 ft 11 in)	In any case, Lateral Gantry parking is only possible at patient head

Figure 58 Distance between Tube Chiller and X-Ray Tube

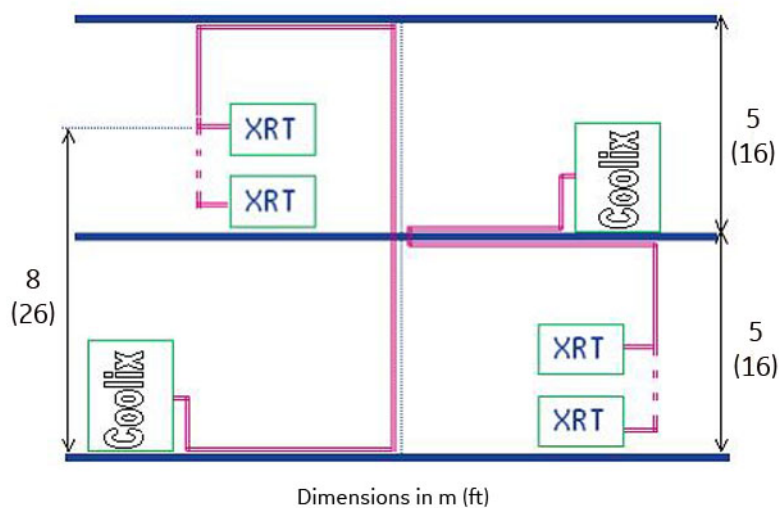

For exam and control rooms, several configurations are possible.

The pre-installation instructions shall define a room layout where the location of the remote controls versus the moving parts of equipment. This layout shall define the maximum distance between the remote control location and equipment and the axis of the equipment (L axis) versus the remote controls (dead angles concern).



CARRIAGE COVERS CAN ENCLOSE DUST PARTICLES. CARE SHOULD BE TAKEN TO AVOID PROPAGATION.

IT IS RECOMMENDED TO AVOID DIRECT AIR FLOW BETWEEN LATERAL GANTRY RAILS.

NOTE

Motion controls installed in remote location from the table shall be installed at a location where all the positioner axis are visible by the operator.

Refer to Illustrations in [2.2.2.1 Patient Room Layout on page 70](#) to see possible exam / control rooms layouts.

2.3 Room Structural Requirements

2.3.1 Floor Requirements

2.3.1.1 General Vascular GE Healthcare Policy

GE Healthcare's Customer is responsible for the structural analysis and mounting of the base plates. If GE Healthcare is forced to mount the base plate, the Local Customer Team must hire a structural engineer to design and approve the mounting method and provide GE Healthcare with an engineering report.

The floor level cannot exceed a general levelness of 5 mm (0.2 in) for any 2 meters (79 in).



NOTICE

The floor slabs on which the equipment is to be installed must have a levelness of 1 mm (0.04 in) per meter (40 in). Position of baseplates and table basement depends on the type of installation. The three types of installation are given in [Figure 59 on page 85](#).

Figure 59

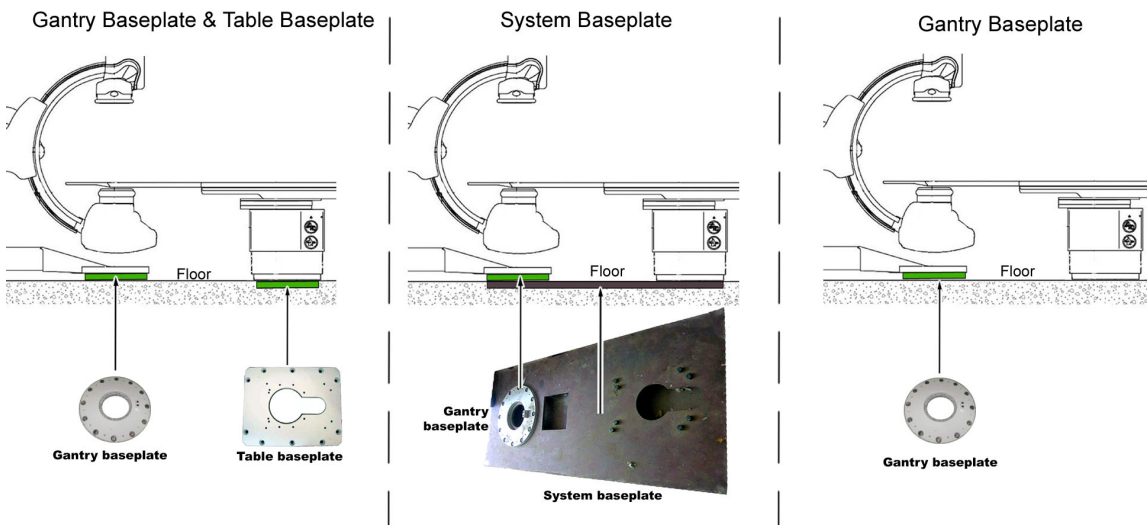

The preferred installation method for the Innova Frontal and Lateral Positioner or the Omega tables is through-bolting. The through-bolting method can be used in all seismic zones. If through-bolting cannot be used, use provided floor anchors instead.

Figure 60 Through-Bolt Supplied (Slab Type Floor Construction)

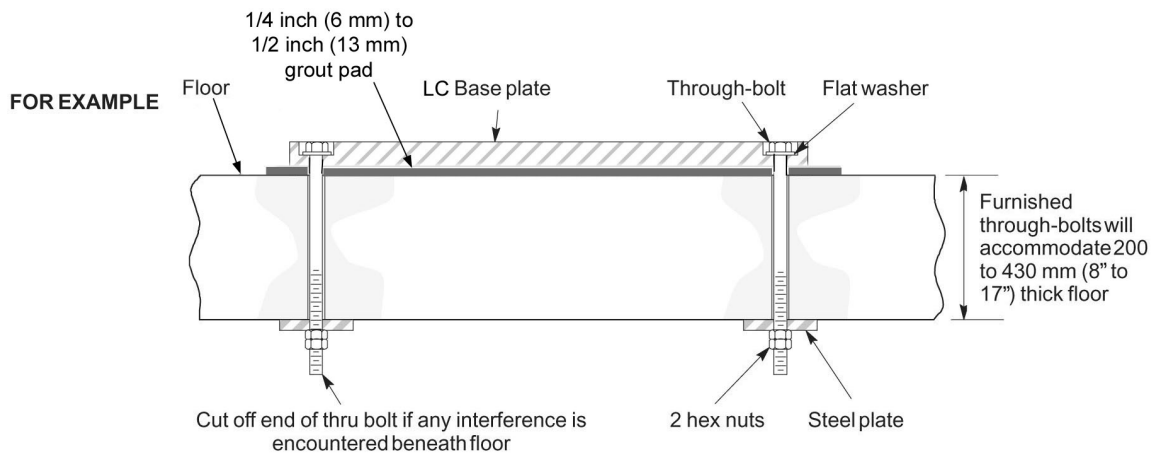

2.3.1.2 Floor requirements when using provided floor anchors

The maximum pullout force per provided anchor was calculated assuming:

- A concrete compression strength of **17.24 MPa** at 28 days (which is the minimum required compression strength).
- Anchors installed to the required hole depth of **165.1 mm (6.5 in)** minimum, and
- Center of anchor hole to concrete edge distance **79.4 mm (3.12 in)**.

Make sure to obtain data on compression strength of the concrete before using floor anchors.

2.3.1.3 Pan Type Floor Construction Requirement

For Pan type floor construction, steel channels must be designed by a local structural engineer to span floor joists. See [Figure 61 on page 86](#).

NOTE

For specific floor preparation procedures, refer to *Single Plane and Biplane Innova Systems Pre-Installation Kit Installation Procedures*.

Figure 61 Through-Bolt Supplied (Pan Type Floor Construction)

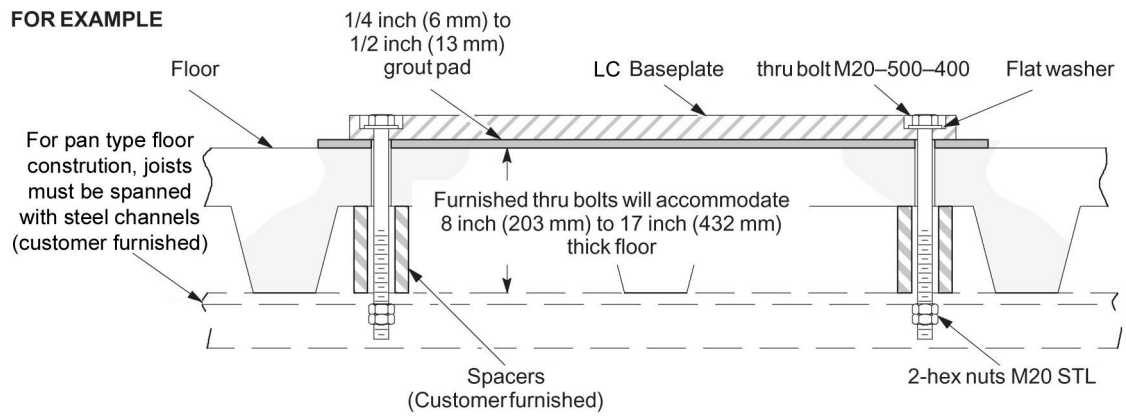
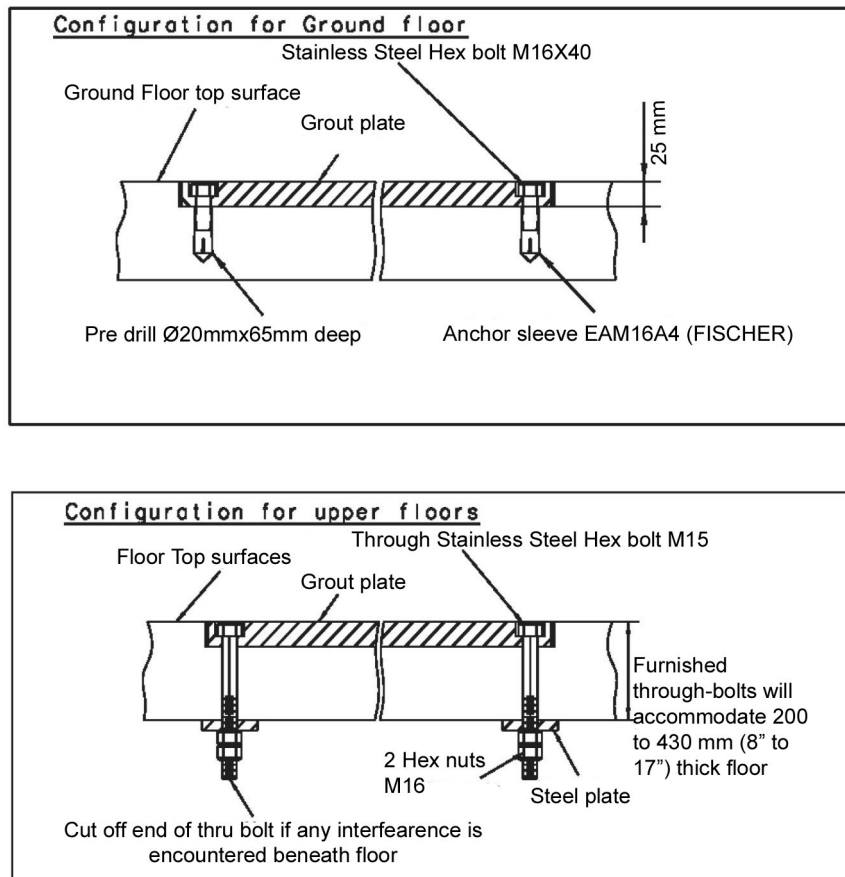

Figure 62 Table baseplate

**NOTE**

Prepare the floor such that the Table baseplate will be flush with the floor surface.

For alternative table bolts or seismic area, refer to template drawing shown in Illustration *Gantry and table mounting holes* contained in [2.3.2 Mounting Requirements](#) on page 91.

2.3.1.4 Hole dimension and preferred location in concrete floor

In the examination room, the Innova Frontal Positioner is not placed on a computer floor but directly put on concrete floor, the location of the cable access needs to be carefully planned.

Otherwise, if the cable run is located under the concrete floor, the cables will have to come through the floor and in this case you will need two holes, one for the Frontal Positioner and the other for the patient table.

The diameter of both holes must be the same 225 mm or 9 in.

Figure 63 Hole location in concrete floor

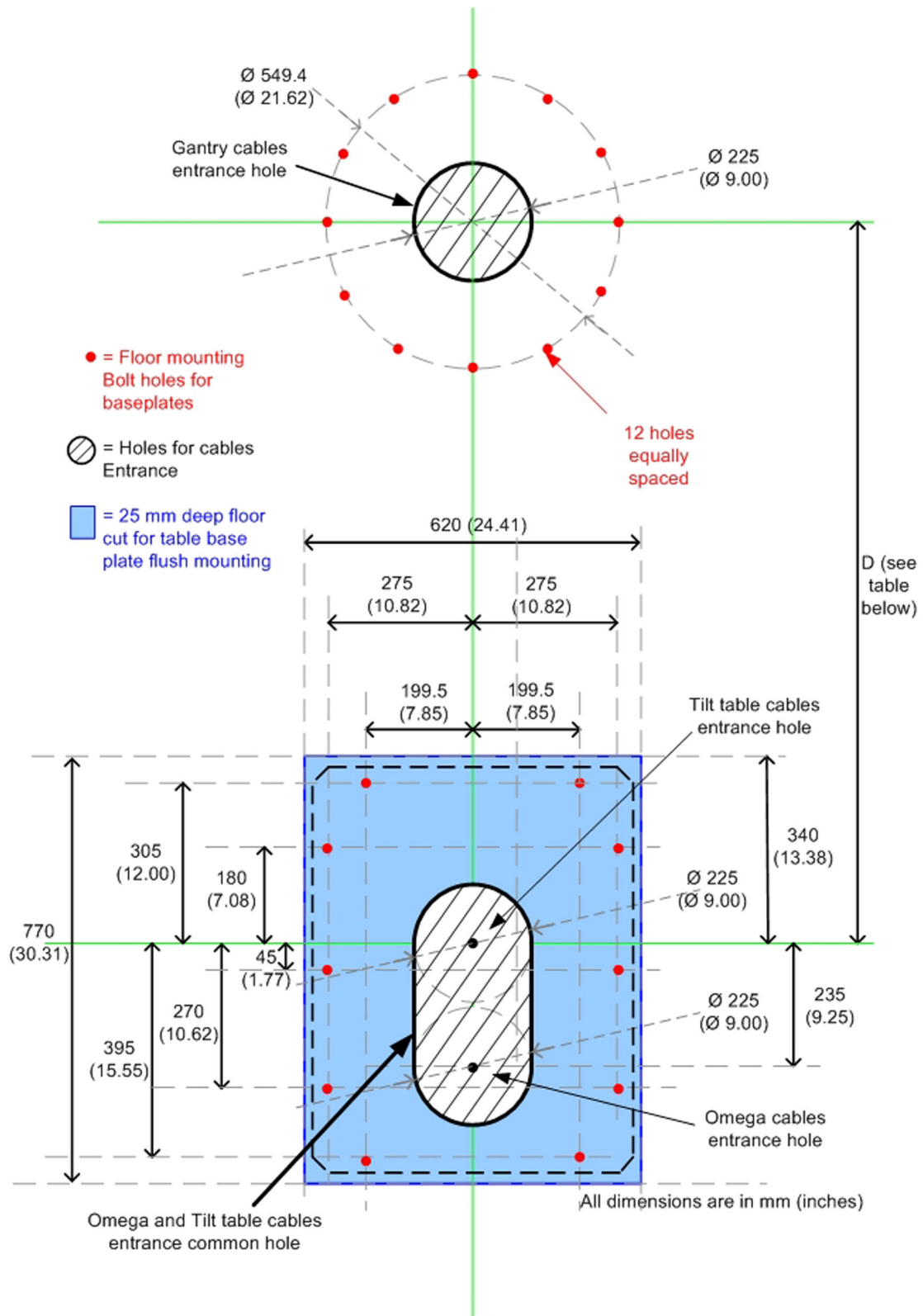

Table 16 D distance of

	ANGIO / CARDIO	CARDIO / NEURO
Omega V Long	1278 mm (50.3 in)	1395 mm (54.9 in)
Omega V non motorized Long	1278 mm (50.3 in)	1395 mm (54.9 in)

NOTICE

Due to the plastic bushing used in the USA to protect cables from the sharp edges of conduits it is necessary to place the cable conduit inside the table cable access opening but the height of the outcoming conduit plus bushing is limited to 12 mm (1/2 in).

NOTE

Refer to table *Chemical anchors Pull out efforts and recommendations* in [2.3.2 Mounting Requirements](#) on page 91 for pull out effort on each fixation bolts.

2.3.1.5 Water Pipe Requirements

Figure 64 Water Conduit location with "Above Grade" anchor kits

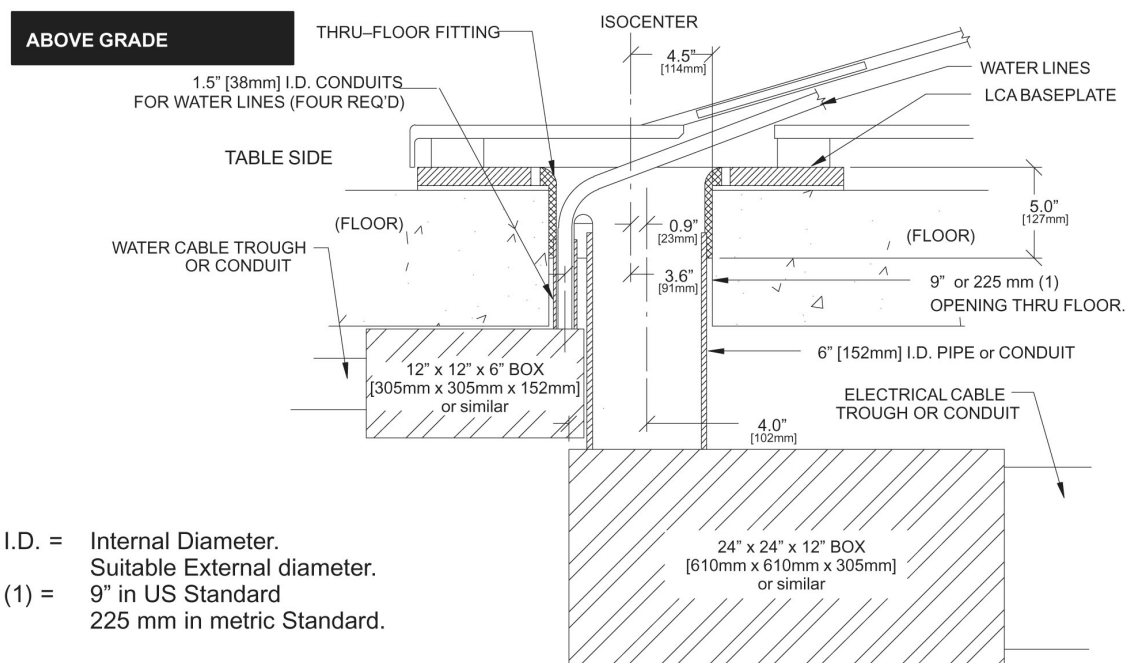

Note: Pipe, junction box and duct or conduit are to be supplied and installed by Customer or customer's Contractor.

NOTICE

In some countries, depending on local regulations, it may be forbidden to run electrical cables and water pipes in the same conduit. In this case, two separate conduits are required.

Figure 65 Water Conduit location with "On Grade" anchor kits

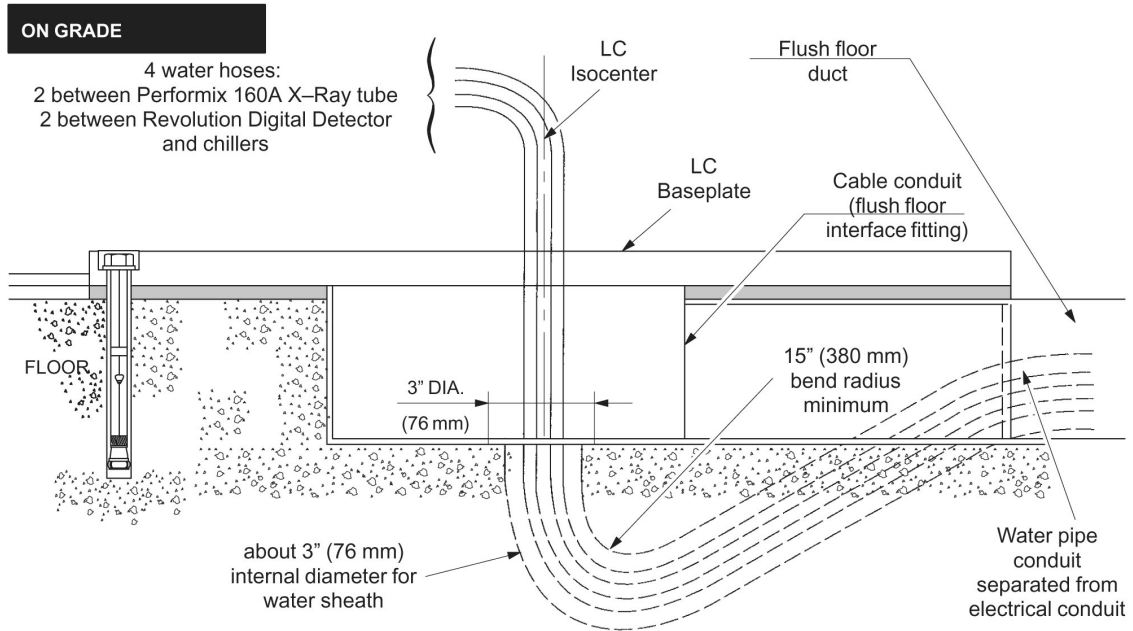

Note: Flush floor interface fitting is part of GEMS installation kit 2286398 and is installed by Customer or customer's Contractor.

NOTE

For further information on kit 2286398 (S18101SK), refer to *Innova Frontal Positioner and Omega/Tilt Table Floor Preparation Kits (GE Healthcare supplied)* in [2.3.2 Mounting Requirements](#) on page 91.

Figure 66 Cable Curvature with "Above Grade" anchor kits

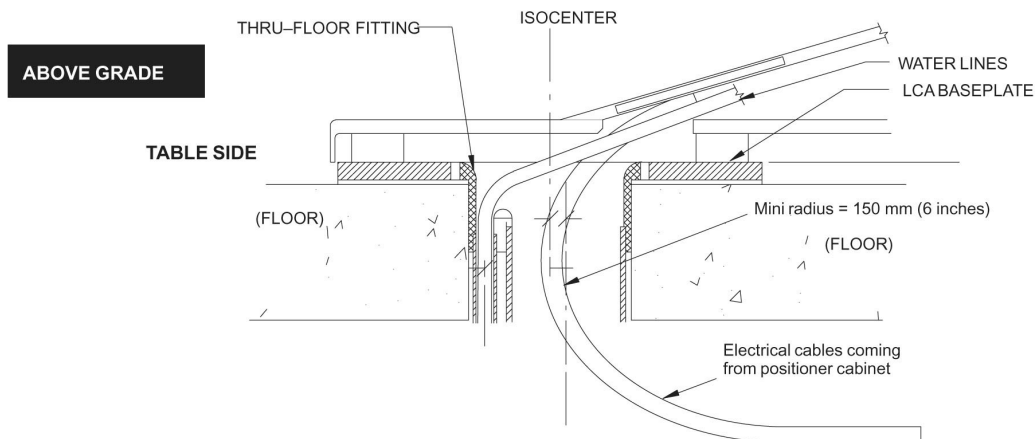

Note: In case of thru-floor cabling, if the electrical cables are coming from the head side, they will need to have a minimum curvature with a minimum radius of 150 mm (6").
In any other cases (i.e. flush floor) no such curvature is allowed.

Figure 67 Cable Curvature with “On Grade” anchor kits

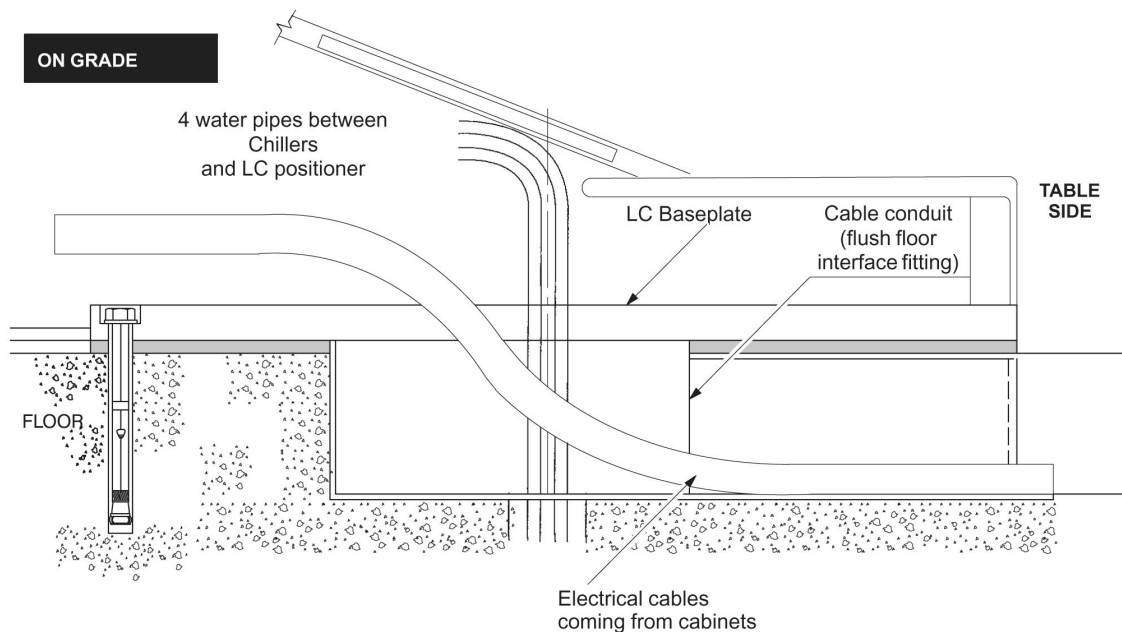
**NOTE**

In case of on grade cabling, because of the minimum curvature constraint of 150 mm (6"), the cable will have to come from the side between Innova Frontal/Lateral Positioner and patient table.

2.3.2 Mounting Requirements

2.3.2.1 Floor Loading and Recommended Mounting Methods

See [Table 17 on page 92](#). To obtain floor loading and recommended mounting methods for components not specified in [Table 17 on page 92](#), refer to the appropriate component Pre-Installation Manual listed in [2.1.5 System Compatibility on page 69](#).

Table 17

PRODUCT OR COMPONENT	NET WEIGHT kg (lbs)	DIMENSIONS mm (in)			LOAD BEARING AREA mm (in)	WEIGHT/ OC-CUPIED AREA kg/m ² (lb/ft ²)	MOUNTING METHOD
		WIDTH	DEPTH	HEIGHT			
Innova Frontal Positioner	670 (1477) for systems with 21 cm detector and 705 (1556) for systems with 31 cm detector	See Illustrations <i>Innova Frontal Position Dimensions</i> : <ul style="list-style-type: none"> Side view Top view Front view in 2.1.3 Dimension Drawings on page 37			Circle diameter 600 (23.62)	2678 (549)	Recommended: <ul style="list-style-type: none"> Through-Bolts (12) Alternates: On Grade 5/8 in, Anchors (12) Above Grade 3/4 in. Anchors (12) See Figure 68 on page 95 , Figure 69 on page 96 and Figure 71 on page 98
Lateral Positioner	735 (1620) for systems with 21 cm detector and 797 (1757) for systems with 31 cm detector	See Illustrations <i>Lateral Positioner Dimensions</i> : <ul style="list-style-type: none"> Side view Top view Front view in 2.1.3 Dimension Drawings on page 37			Not applicable	Not applicable	Not applicable
Table	741.6 (1,635) See NOTE 1	See Illustration <i>Omega Table Dimensions</i> in 2.1.3 Dimension Drawings on page 37			571x425 (22.5x16.7)	3065 (628)	Same as Innova Frontal Positioner
C2 Cabinet	262 (578)	See Illustration <i>C2 Cabinet Dimensions</i> in 2.1.3 Dimension Drawings on page 37			600x900 (23.63x35.44)	485 (99)	Not applicable
C1 Frontal Cabinet	367 (809)	See Illustration <i>C1 Frontal Cabinet Dimension</i> in 2.1.3 Dimension Drawings on page 37			600x900 (23.63x35.44)	680 (139)	Not applicable

continued							
PRODUCT OR COMPONENT	NET WEIGHT kg (lbs)	DIMENSIONS mm (in)			LOAD BEARING AREA mm (in)	WEIGHT/ OC-CUPIED AREA kg/m ² (lb/ft ²)	MOUNTING METHOD
		WIDTH	DEPTH	HEIGHT			
C1 Lateral Cabinet	314 (692)	See Illustration <i>C1 Lateral Cabinet Dimension</i> in 2.1.3 Dimension Drawings on page 37			600x900 (23.63x35.44)	581 (119)	Not applicable
COOLIX 4100	120 (264.5)	555 (21.8)	610 (24)	1200 (47.2)		424 (87)	Not applicable
Autotransformer (Coolix 4100)	30 (66)	370 (14.5)	304 (12)	340 (13.4)		312.50 (64)	Not applicable
Detector Con-ditioner	14.6 (32)	See Illustration <i>Thermo-Con Detector Conditioner (and Mounting brackets) Dimensions</i> in 2.1.3 Dimension Drawings on page 37			Not applicable	Not applica-ble	Not applicable
UPS 1 kVA	14.5 (32)	See Illustration <i>1 kVA Cabinet UPS - model 9130</i> in 2.1.3 Dimension Drawings on page 37			Not applicable	Not applica-ble	Not applicable
UPS 3 kVA	36 (79)	See Illustration <i>3 kVA LDM UPS - model 9130</i> in 2.1.3 Dimension Drawings on page 37			Not applicable	Not applica-ble	Not applicable
Fluoro UPS UL Inverter cabi-net	541 (1065)	680.2 (26.78)	800 (31.5)	1800.9 (70.90)		975 (200)	Not applicable
Fluoro UPS CE	483 (1064)	680 (26.8)	800 (31.5)	1450 (57.1)		883 (181)	Not applicable
Power Distri-bution Box CE	225 (496)	800 (31.5)	300 (11.8)	1800 (70.8)		Not applica-ble	Not applicable
Power Distri-bution Box UL	389.5 (859)	1016 (40)	356 (14)	2120 (83)	Not applicable	Not applica-ble	Not applicable
Precabled 19" LCD monitor suspension for 6 monitors	115 (254)	See illustration <i>LCD 6 moni-tors suspension dimensions (Optional)</i> in 2.1.3 Dimension Drawings on page 37				Not applica-ble	Not applicable
LD cabinet	115 (254)	550 (22)	780 (31)	1250 (49)	550x780 (22x31)	268 (55)	Not applicable

continued							
PRODUCT OR COMPONENT	NET WEIGHT kg (lbs)	DIMENSIONS mm (in)			LOAD BEARING AREA mm (in)	WEIGHT/ OC-CUPIED AREA kg/m ² (lb/ft ²)	MOUNTING METHOD
		WIDTH	DEPTH	HEIGHT			
LD suspension precabled (self weight without monitor and accessories given)	215 (474)	See Illustration <i>Large Display suspension dimensions (Optional)</i> in 2.1.3 Dimension Drawings on page 37			Not applicable	Not applicable	Not applicable
Precabled LD Mavig suspension with fixed point dual arm	190 (419)	See Illustration <i>Top View of the MAVIG suspension with fixed point dual arm for Large Display (Optional)</i> in 2.1.3 Dimension Drawings on page 37			Not applicable	Not applicable	Not applicable
Substructure for Dual Arm suspension (for LD Mavig suspension with fixed point dual arm)	58 (128)	See Illustration <i>Suspension with fixed point dual arm: Top View of the Ceiling Plate</i> in 2.1.3 Dimension Drawings on page 37			Not applicable	Not applicable	Not applicable
LD monitor	47 (103)	1319 (52)	146 (6)	776 (31)	Not applicable	Not applicable	Not applicable

NOTE

(1) including patient weight. Patient weight is considered 204 kg (450 lbs).

NOTE

(2) Depth.

2.3.2.2 Positioner and Table Floor Mounting

The distances between the Innova Frontal Positioner and the Tables are critical for a proper clinical usage. For this reason, GE Healthcare provides two floor mounting templates to ensure these components are properly placed in relation to one another.

Table 18

Title	Illustration
Innova Frontal Positioner Floor Mounting Methods	Figure 68 on page 95 and Figure 69 on page 96
Cable Conduit For On-Grade Floor Anchor Kit	Figure 71 on page 98

continued	
Title	Illustration
Inner Base Plate For Above Grade Floor Anchor Kit	Figure 70 on page 97
Fixing Bolt Overview	Figure 72 on page 99
Gantry and table mounting holes	Figure 73 on page 101

Figure 68 Innova Frontal Positioner Floor Mounting Methods (1/2)

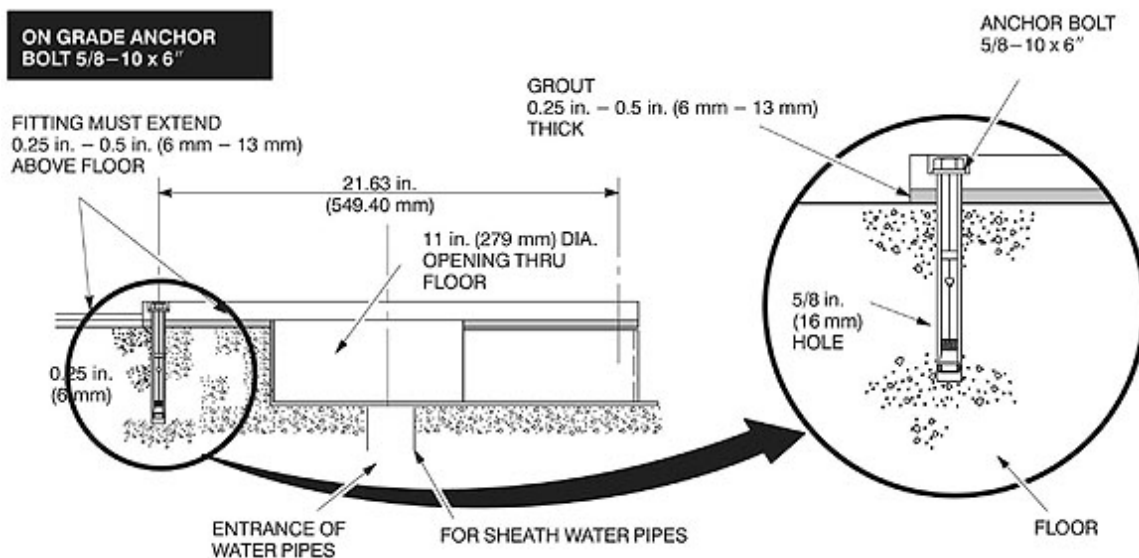
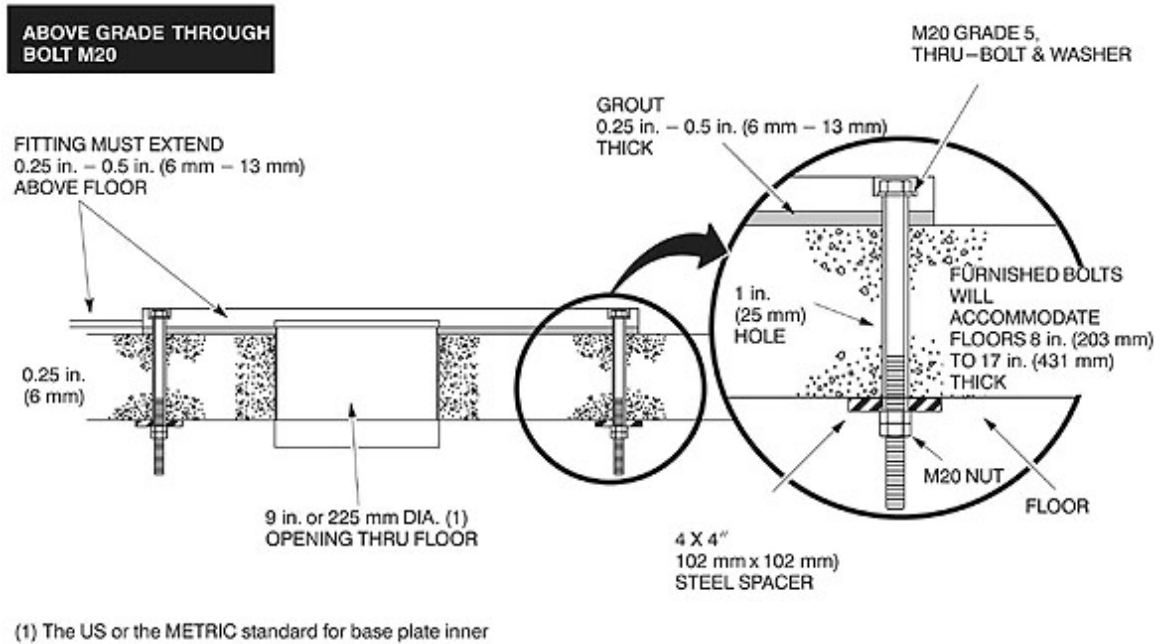

Figure 69 Innova Frontal Positioner Floor Mounting Methods (2/2)

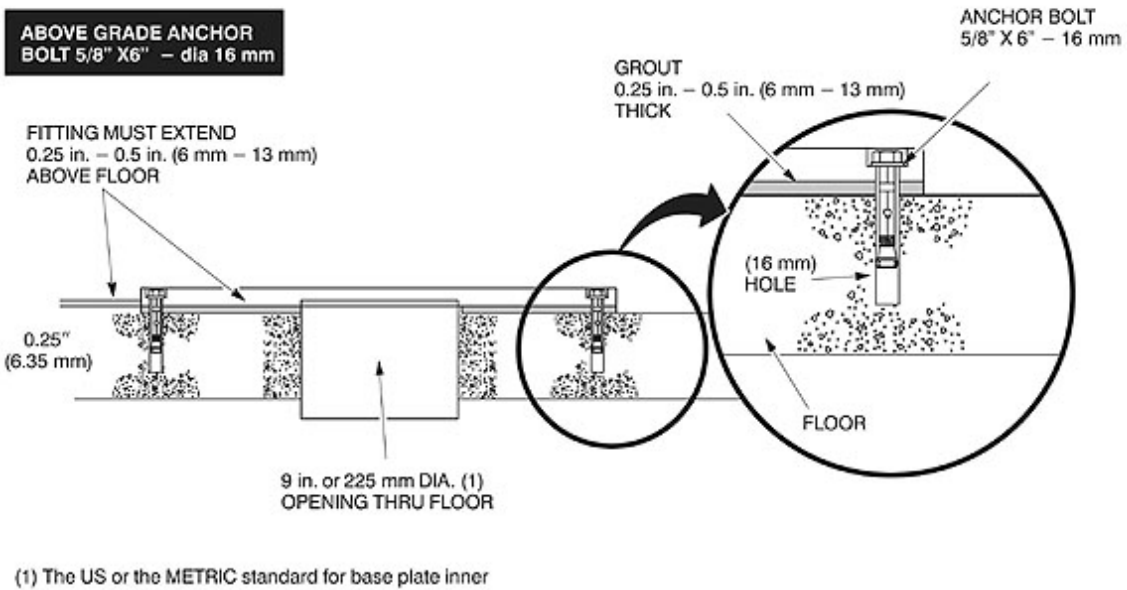
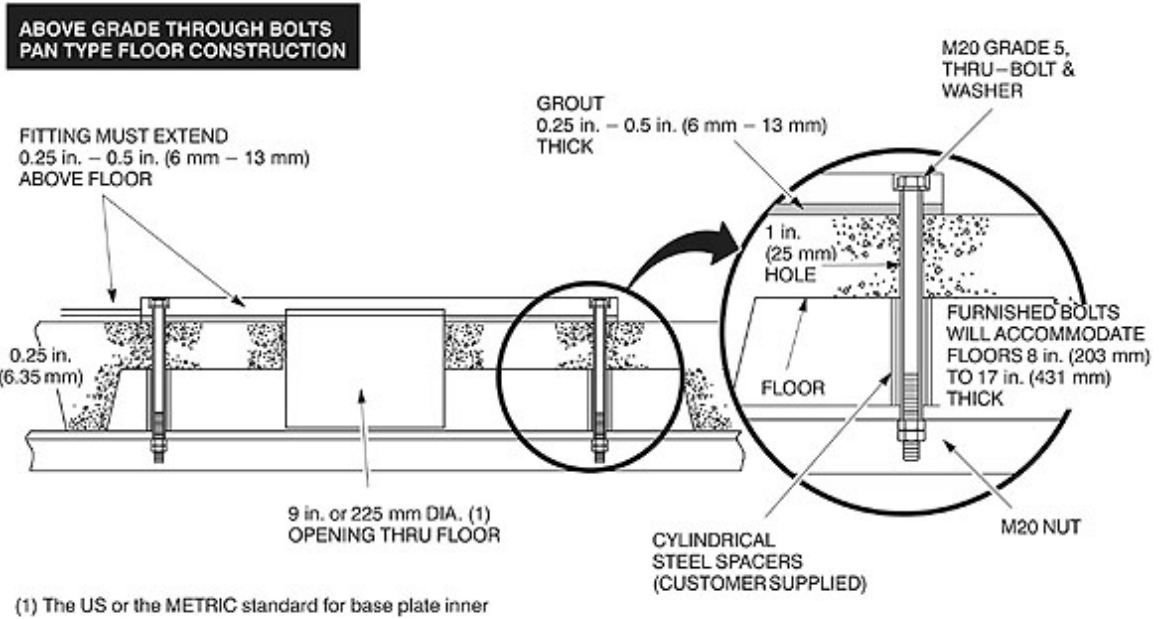

Figure 70 Inner Base Plate For Above Grade Floor Anchor Kit

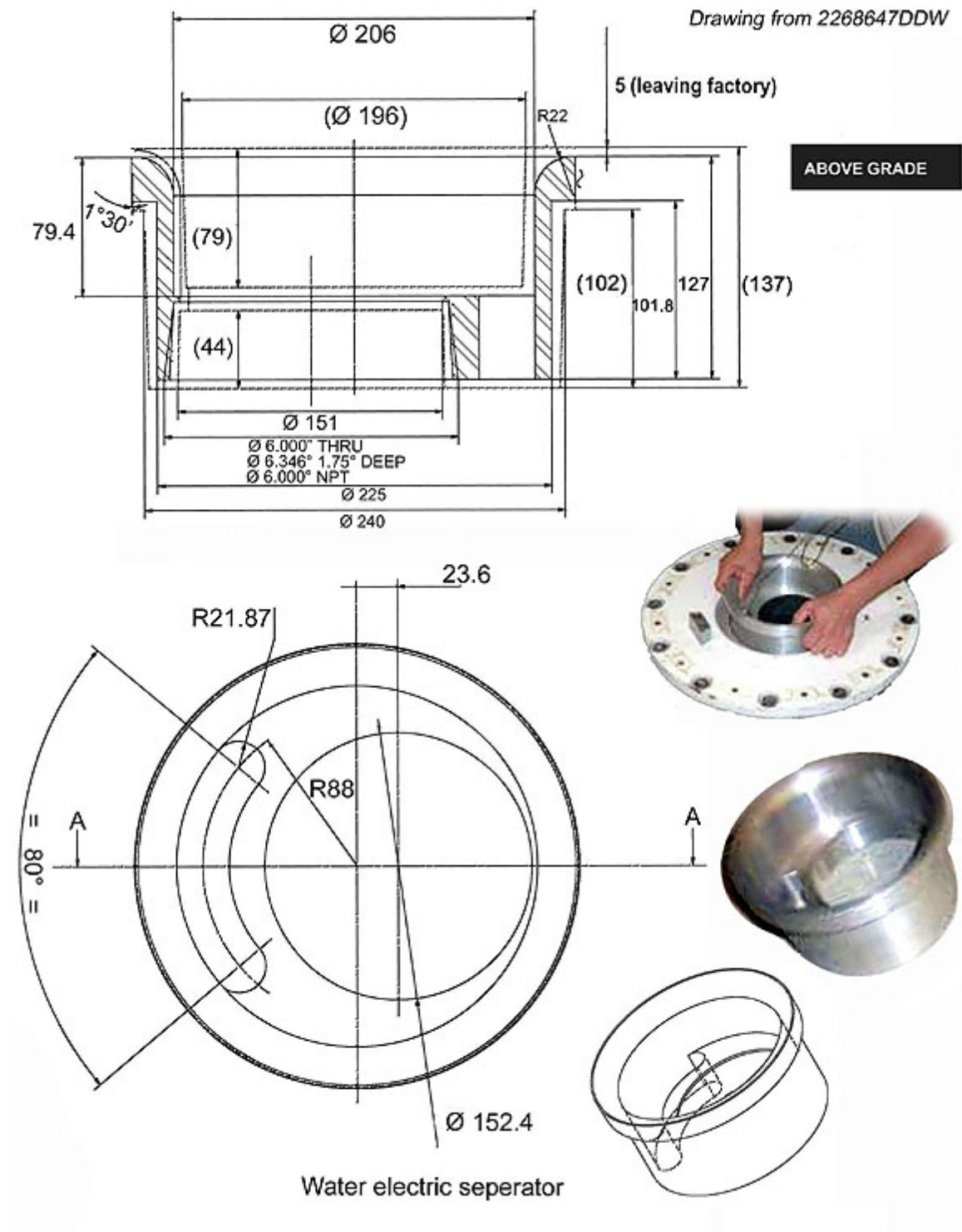
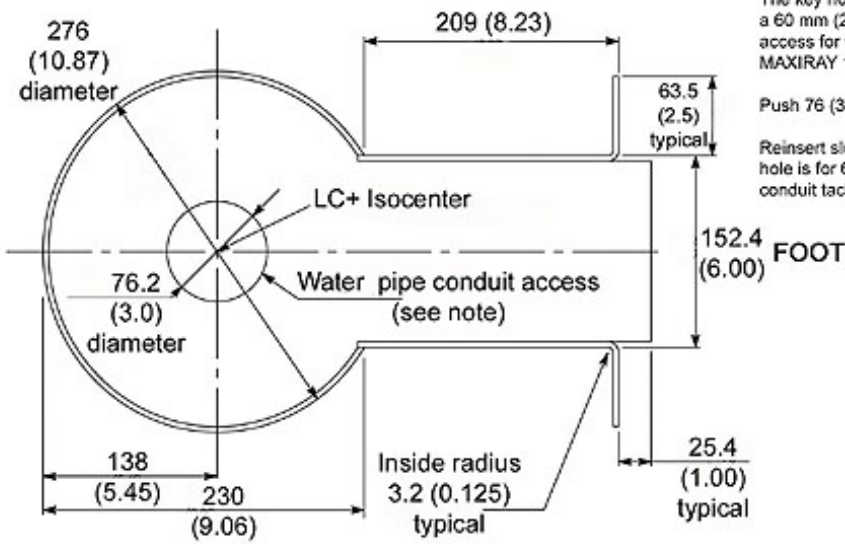

Figure 71 Cable Conduit For On-Grade Floor Anchor Kit



Dimensions in mm (inches)

ON GRADE



The key hole has been redesigned to permit a 60 mm (2.5 in.) water conduit to separate access for waterpipes used with a MAXIRAY 150.

Push 76 (3.0) hole in center.

Reinsert slug and tack well in one spot hole is for 63.5 (2.5) internal diameter conduit tack well from bottom if possible.

FRONT VIEW

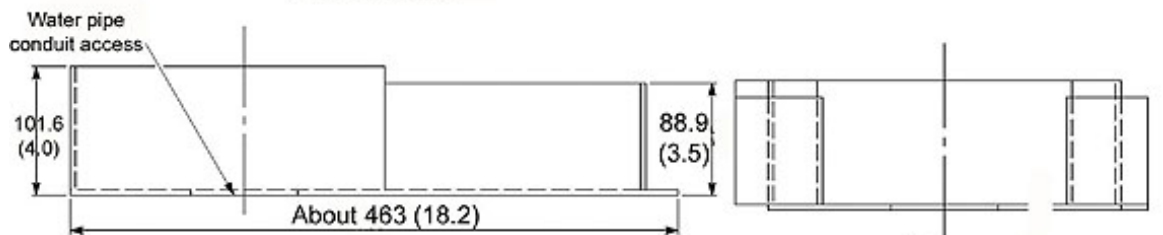

Steel plate (0.12 in) OR 3mm Thickness

FINISH: FINISHED

SIDE VIEW

FRONT VIEW (FOOT END)

Figure 72 Fixing Bolt Overview

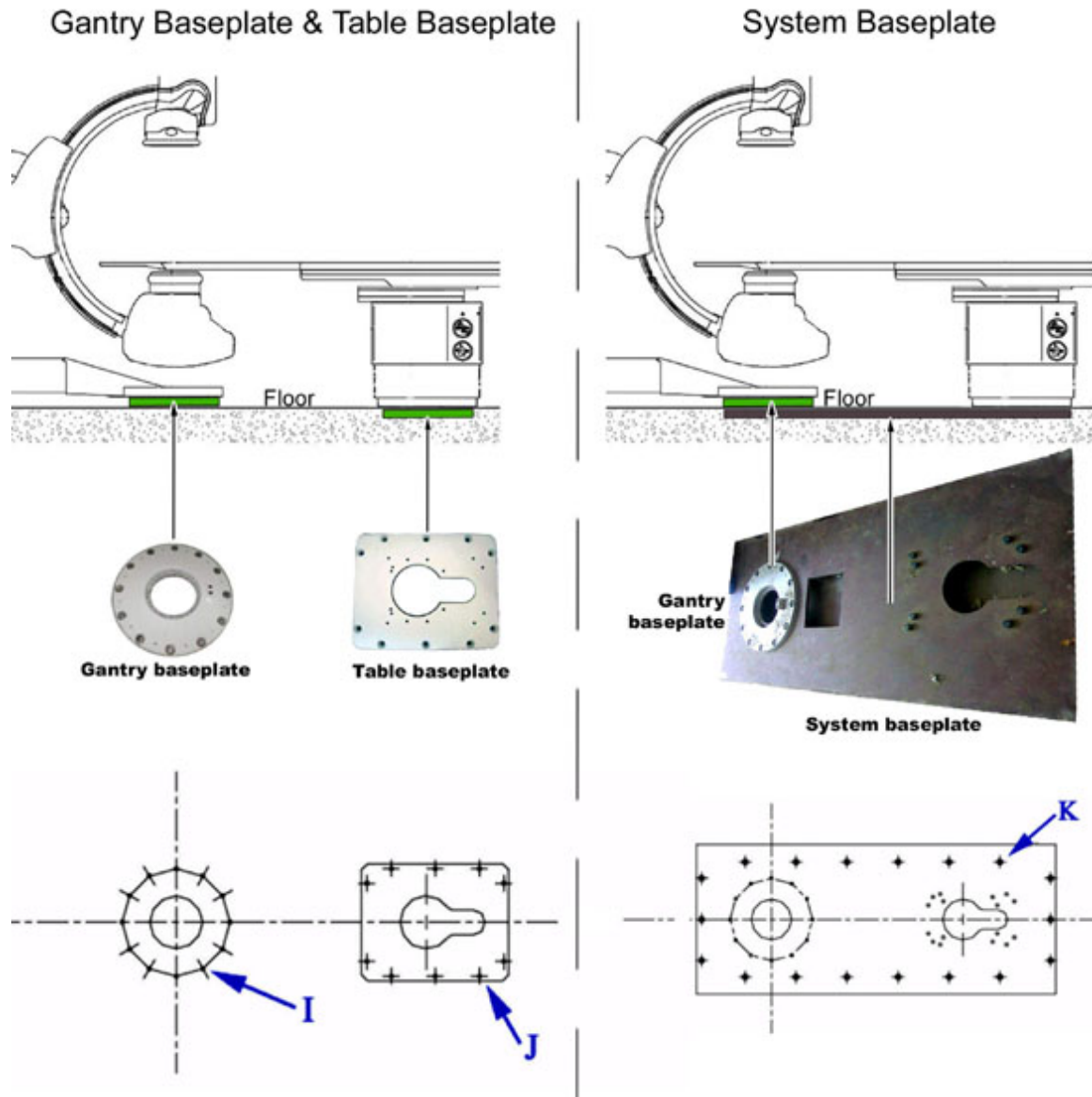

NOTE

For more details on Table Baseplate, refer to [Figure 73 on page 101](#).

NOTE

With any kind of fixation methods (Bolts M20, Mechanical anchors or Chemical anchors), the number of holes used mandatory is:

- Gantry baseplate : 12 max and 8 min holes used are acceptable
- Table baseplate : 10 max and 8 min holes used are acceptable
- Floor baseplate : 24 max and 12 min holes used are acceptable

We can have only 2 consecutive holes omitted.

Pull out efforts and recommendations about chemical anchors not provided by GE.

The following table provides the recommended chemical anchors for Table/Frontal baseplates and for the floor plate ordered locally that they could be used instead of bolts provided by GE.

Table 19 Chemical anchors Pull out efforts and recommendations

	Gantry baseplate	Table baseplate	Floor plate (to be ordered locally)	Table Omega
Mark	<i>I</i> on Figure 72 on page 99	<i>J</i> on Figure 72 on page 99	<i>K</i> on Figure 72 on page 99	<i>A</i> on Figure 73 on page 101
Pull out effort	736 daN per bolt if 12 used and 1992 daN per bolt if 8 used	1120 daN per bolt if 10 used and 2000 daN per bolt if 8 used	272 daN per bolt if 24 used and 2008 daN per bolt if 12 used	4432 daN per bolt with 4 bolts
Number of holes in the plate	12 max (8 min mandatory)	10 max (8 min mandatory)	24 max (12 min mandatory)	4 mandatory
Recommended chemical anchors example 1	Supplier HILTIHVU adhesive capsule + HAS Anchor rod	Supplier HILTIHVU adhesive capsule + HAS Anchor rod	Supplier HILTIHVU adhesive capsule + HAS Anchor rod	Supplier HILTIHVU adhesive capsule + HAS Anchor rod
Threaded rod	M16 A4-70 / 333 131 5/8	M20 A4-70 / 333 135 3/4	M16 A4-70 / 333 131 5/8	M20 A4-70 / 333 135 3/4
Hole diameter in the floor	18 mm (11/16 in)	24 mm (7/8 in)	18 mm (11/16) in	24 mm (7/8 in)
Hole depth in the floor	125 mm (5 in)	170 mm (6-5/8 in)	125 mm (5 in)	170 mm (6-5/8 in)
Minimum floor thickness	180 mm (7 in)	220 mm (8-1/2 in)	180 mm (7 in)	220 mm (8-1/2 in)
Max Tightening Torque	80 N.m (59 ft-lb)	150 N.m (110 ft-lb)	80 N.m (59 ft-lb)	150 N.m (110 ft-lb)

NOTE

The floor plate ordered locally needs to be in steel.

Refer to supplier technical documents for all specification and installation data about chemical anchors.

Figure 73 Gantry and table mounting holes

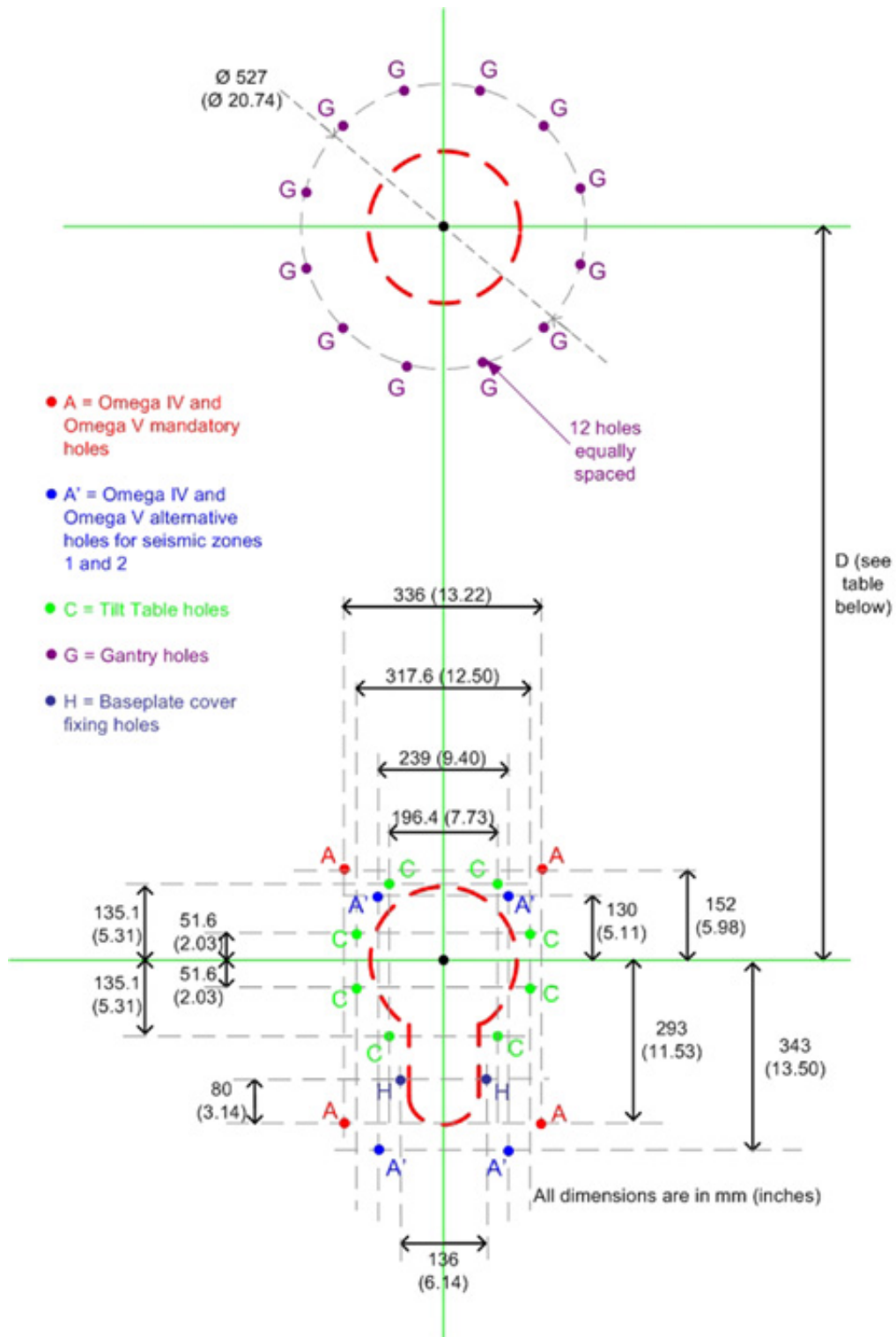

Table 20 D distance of

	ANGIO / CARDIO	CARDIO / NEURO
Omega V Long	1278 mm (50.3 in)	1395 mm (54.9 in)
Omega V non motorized Long	1278 mm (50.3 in)	1395 mm (54.9 in)

2.3.2.3 Innova Frontal Positioner and Table Floor Preparation Kits (GE Healthcare supplied)

Refer to *Single Plane and Biplane Innova Systems - Pre-Installation Kit Installation Procedures*.

2.3.2.4 Injector Mounting Requirements



Table accessory rail load consideration: The maximum load per table accessory rail is 40 kg at 150 mm (60 N.m). Therefore:

- - Only light extra load not exceeding 5 kg at 100 mm (i.e IV pole with its accessories, pressure head...) is authorized on the same table accessory rail as the injector.
- - Never install injector and radiation protection on the same table accessory rail.
- - Typical installation on the front table accessory rail is Smart handle or Smart box, Table Side System Control (TSSC), InnovaCentral/ Touchscreen, Table panning device and cables support.
- - If needed an optional rail can be installed at table foot end of the Omega V table for other options.

2.3.2.5 Prerequisites for ECG Acquisition Kit Installation

2.3.2.5.1 General Prerequisites for ECG Acquisition Kit Installation

Verify the following items to ensure easy mounting for the Hubican & Physio modules in all situations:

1. Check enough space can be managed to properly install the Hubican module in Control Room.
2. Check enough space can be managed to route/hide Hubican cable (VCIM-to-Hubican 12m long cable) in Control Room.

2.3.2.5.2 Specific Prerequisites for Installation Configuration #1

Verify the following items only in the case of Installation Configuration #1 with ECG Device in Control Room:

1. Check the environment of the ECG Device module located in Control Room provides enough space to install the Physio module at a max distance of 1 meter.
2. Check enough space can be managed to properly route/hide Physio cable (Physio-to-Hubican) in the Control Room
3. The Analog Output Box option is mandatory to provide on analog output connection to the Physio module (If not present, it can be ordered through the following FRUs):
 - 2018971-001 16CH ANALOG OUTPUT CPU INTERFACE OPTION
 - 2007557-002 KIT ANALOG OUTPUT BOX W/CABLES
 - 2010476-001 BOX CARDIOLAB/MACLAB ANALOG OUTPUT

2.3.2.5.3 Specific Prerequisites for Installation Configuration #2

Verify the following items only in the case of Installation Configuration #2 with ECG Device in Exam Room:

1. Check the environment of the ECG Device module located in Exam Room provides enough space to install the physio module at a max distance of 1 meter.
2. Check enough space can be managed to properly route/hide Physio cable (Physio-to-Hubican) at table base area.
3. Check the conduit normally designed for MacLab signal cables is present (see conduit illustration in [5.3.2 Cable Channeling on page 154](#)).

2.3.2.6 Large Display Subsystem option



General safety instructions

- Move the LD Cabinet & LD Monitor in an upright position in their original packages to the final destination room. To lift the LD cabinet, use a forklift or lifting belts with spreader bars.
- Check for sufficient floor and elevator loading capacity.
- Check the integrity of the LD Subsystem equipment carefully.
- If you notice visible damage, do not install or start the LD Subsystem equipment. Contact the nearest Service Center immediately.
- All installation, maintenance and service work should be performed by qualified Service personnel.

2.3.3 Ceiling Requirements

2.3.3.1 Gantry rails

The required ceiling rail height for the Gantry is 2845 mm +/-5 mm (9 ft. 4 in +/-0.2 in). The rails must be mounted so that the distance from isocenter to the wall where the park position is designated is an

absolute minimum of 3081 mm (10 ft. 1 in). The recommended distance is equal to 4.381 m (14 ft 5 in). This includes the 150 mm (6 in) clearance between the end of the rails and the wall. See [Figure 74 on page 104](#) and [Figure 75 on page 105](#) Potential Wall Interferences. Also, the lips on the rails must face toward isocenter.

NOTE

Do not attempt to install the Gantry at any height other than 2845 mm (9 ft. 4 in) without first contacting your General Electric Medical Systems representative.

The ceiling suspension rails must be parallel to each other. The distance between the center of the rail mounting holes must be 97.8 -0 +0.2 cm. (38-1/2, -0 +1/16, in). The rails must be level to 3 mm (1/8 in) over the entire length of the rail.

NOTE

It is the responsibility of the Hospital's Contractor to properly install the Gantry Stationary rails per the room drawings.

Figure 74 Location of Stationary Rails on Ceiling – Delivered & Recommended max. configuration

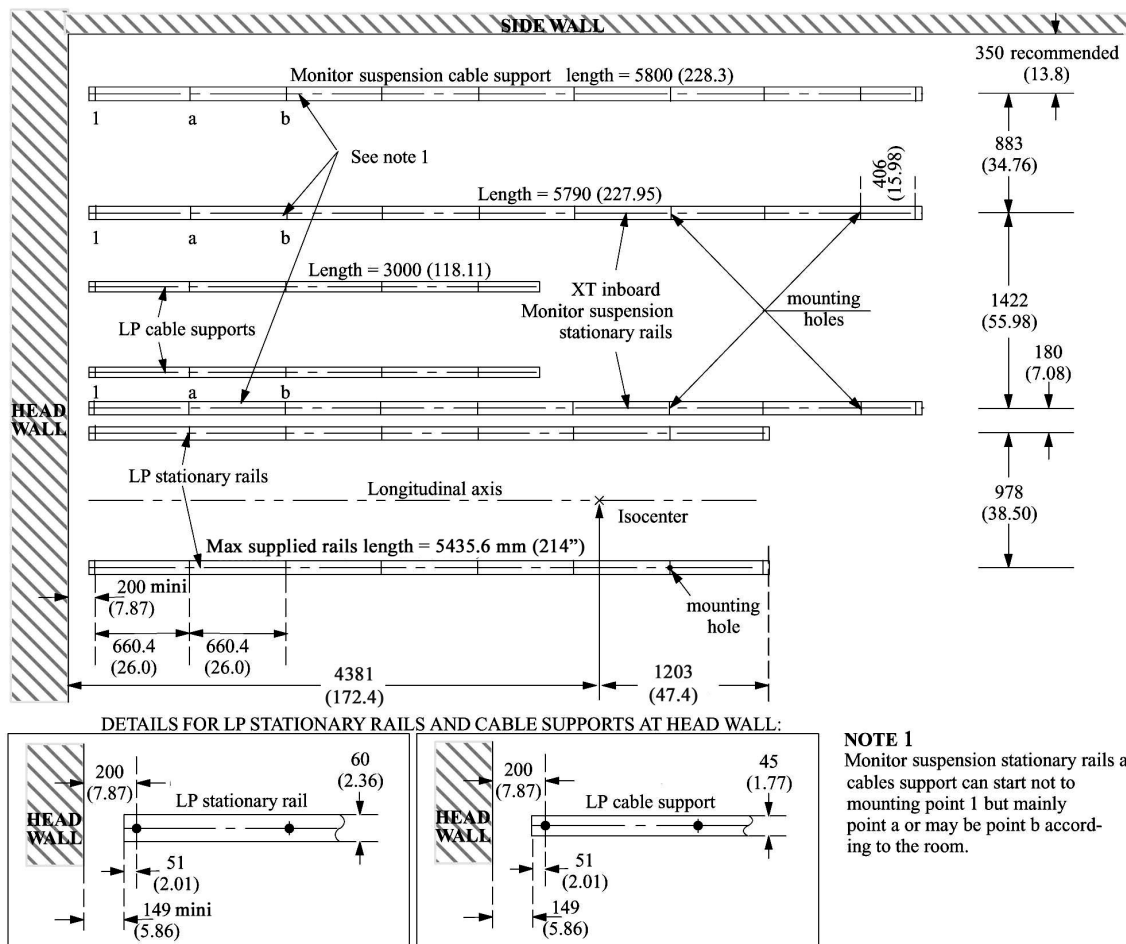

NOTE 1
Monitor suspension stationary rails and cables support can start not to mounting point 1 but mainly point a or may be point b according to the room.

NOTE

It is recommended to install the Gantry Stationary Rails at the maximum configuration (Figure 74 on page 104). Some room configurations may require shorter configurations. Figure 75 on page 105 shows the *Absolute Minimum* configuration allowed.

Figure 75 Location of Stationary Rails on Ceiling – Absolute min. configuration

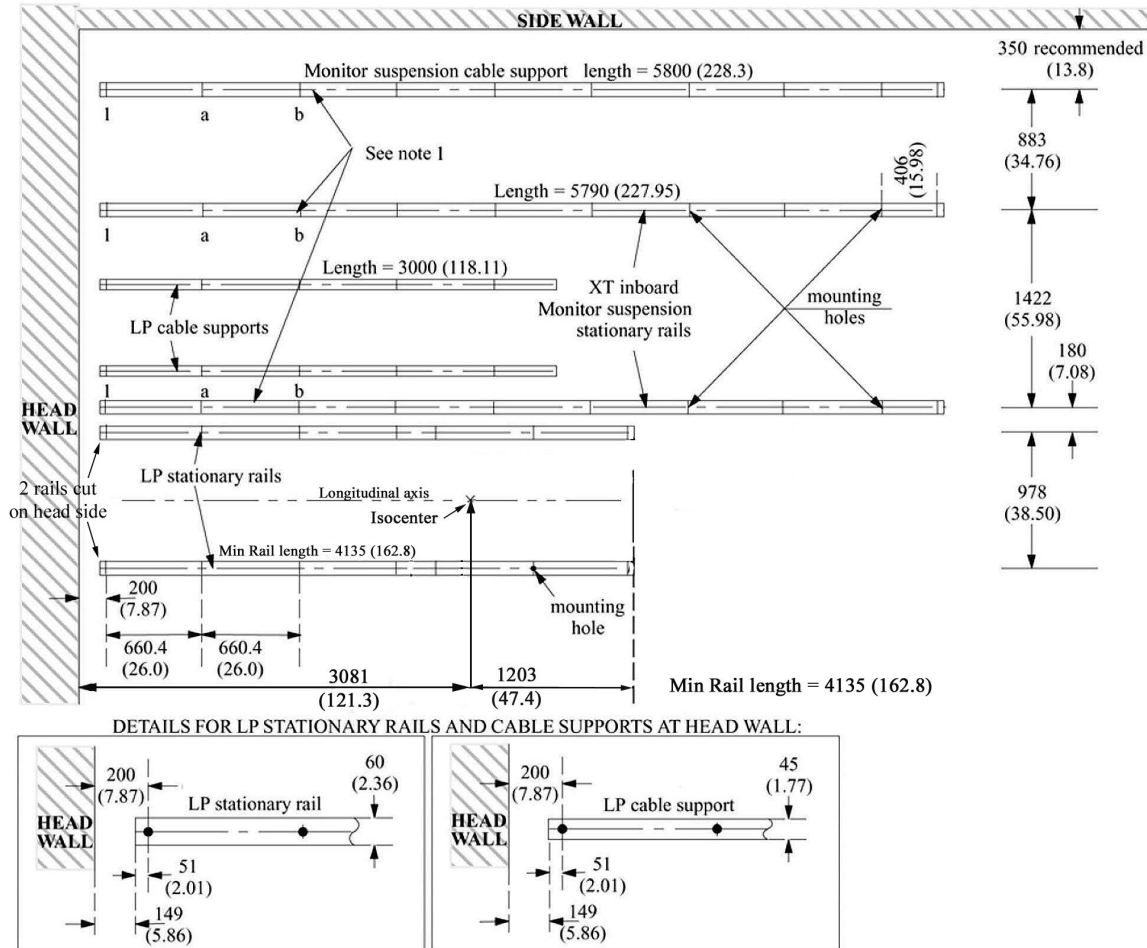

NOTE 1
 Monitor suspension stationary rails and cables support can start not to mounting point 1 but mainly point a or may be point b according to the room.

Figure 76 Gantry Rail Mounting Specifications

Dimensions numbered 1 to 8

From REF to 1	26" ± 1/16 (660.4mm ± 1.6 mm)
From REF to 2	52" ± 1/16 (1,321mm ± 1.6 mm)
From REF to 3	78" ± 1/16 (1,981mm ± 1.6 mm)
From REF to 4	104" ± 1/16 (2,642mm ± 1.6 mm)
From REF to 5	130" ± 1/16 (3,303mm ± 1.6 mm)
From REF to 6	156" ± 1/16 (3,962mm ± 1.6 mm)
From REF to 7	182" ± 1/16 (4,623mm ± 1.6 mm)
From REF to 8	208" ± 1/16 (5,283mm ± 1.6 mm)

Note that tolerances are NOT cumulative

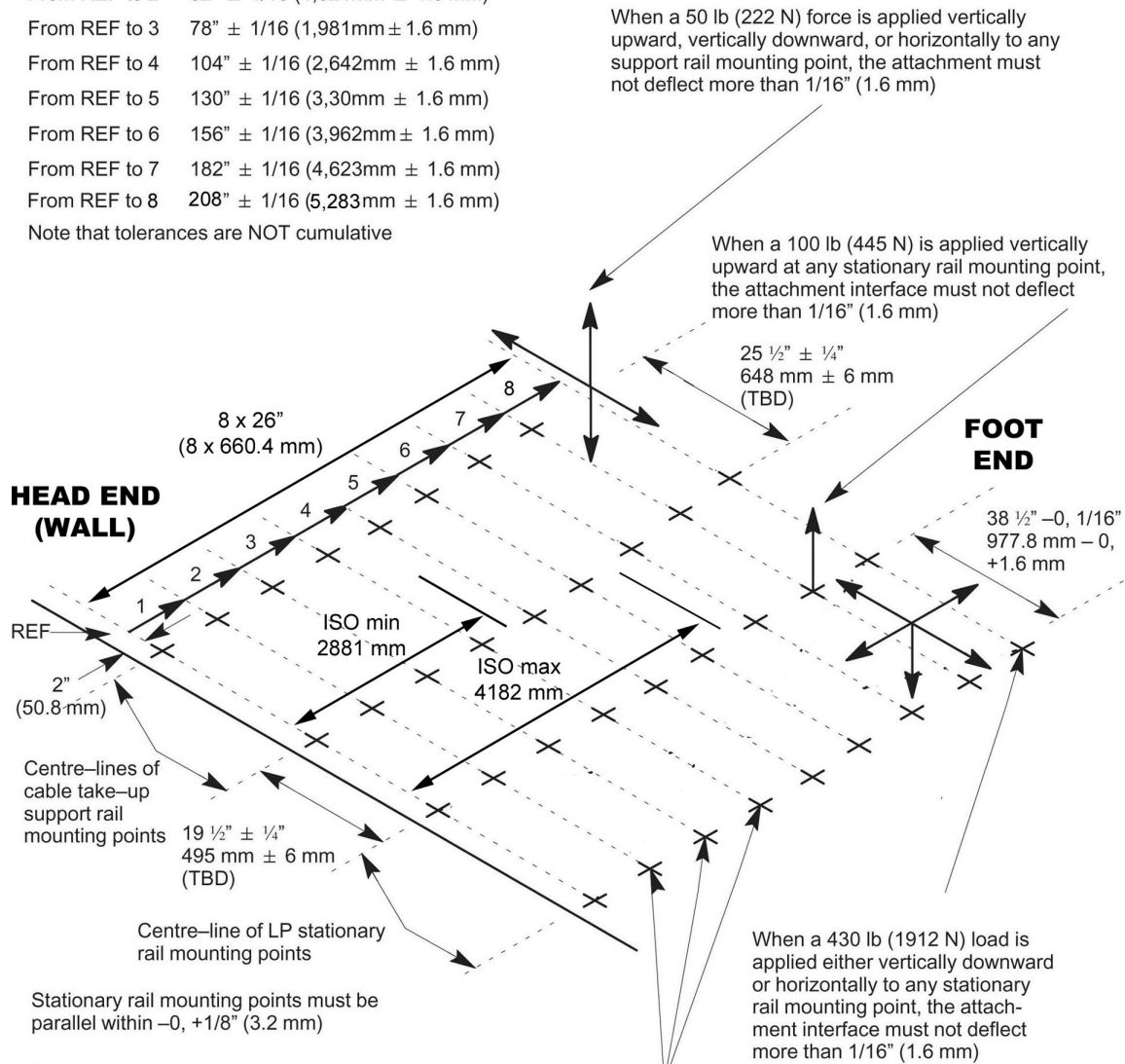

CAUTION:

- The maximum load per bolt will not exceed **430 lbs. (1912 N)**.
- Each bolt must not "pull out" or otherwise fail under a vertically downward "dead" load of **1717 lbs. (7633 N)**.

The height of each mounting point must be within +1/16" (1.6 mm) of the height of its neighbour, but the difference between the highest and lowest must not exceed 3/32" (2.4 mm)

STRUCTURE SHOULD NOT ALLOW VIBRATIONS TRANSMISSION EQUAL OR LOWER THAN 10 Hz

2.3.3.2 Monitor Suspension Rails

Aluminum rails support the In-room Monitor Bridge used in systems with 21 and 31 cm detector X-Ray rooms.

2.3.3.2.1 Reference

For additional details on ceiling requirements for stationary rails, refer to:

- Direction 46-019639, *Advantx (VHLA) XT Stationary Rails Installation and Adjustment*.
- Direction 2393190-100, *Pre-Installation Manual for LCD Monitor Suspension with 4, 6, or 8 monitors*.

2.3.3.2.2 Rail Mounting

Attach stationary rails to structural steel with through-bolts in concrete ceilings. Do not use screw anchors in direct tension.

Mount stationary rails directly to the ceiling slab or to flush-mounted unistrut or halfen structure. In higher rooms with false ceiling, mount stationary rails to rigid vertical members hung from ceiling slab.

Securing a supplementary channel to the bottom of the vertical members and mounting the stationary rails to this channel can greatly reduce the number of vertical members.

The stationary rail support structure must be leveled before installation can begin. Do not assume that any support structure is level within specified tolerances, particularly after removing suspensions from an existing room.

2.3.3.2.3 Bolt Specifications

- The maximum load per bolt will not exceed **350 lbs (1557 N)**.
- Each bolt must not “pull out” or otherwise fail under a vertically downward *dead* load of **1400 lbs (6228 N)**.

2.3.3.2.4 Rails selection

Monitor suspension rails in different lengths can be selected. Please refer to the GTC or contact the GE representative.

2.3.3.3 Third Party Monitor suspension (option)

Attention must be paid to the height of suspended elements of the third party suspension, collision must be avoided with the gantry.

Figure 77 Potential collision between Lateral gantry/carriage and detector lift

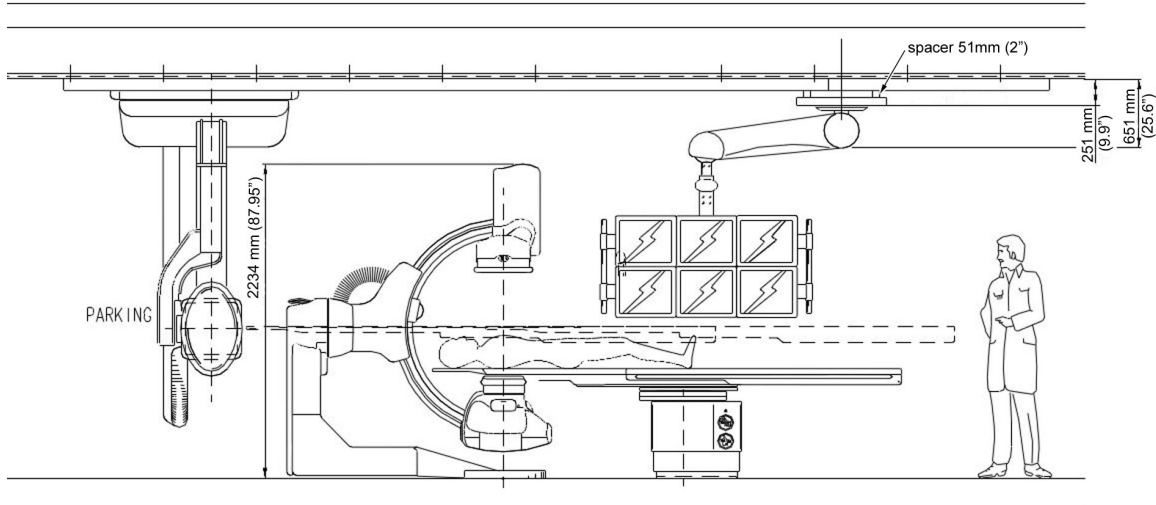

2.3.3.4 Large Display Monitor suspension with fixed point dual arm

2.3.3.4.1 General Policy

The customer is responsible for the structural analysis and mounting of the Substructure for Dual Arm suspension in the solid ceiling (in case of a Large Display Monitor and the MAVIG suspension with fixed point dual arm). If customer requires GEHC to mount the Substructure for Dual Arm suspension, the customer must hire a structural engineer to design and approve the mounting method and provide GEHC with an engineering report.

Figure 78 Medium Height Substructure for Dual Arm Suspension and MAVIG Suspension with Fixed Point Dual Arm

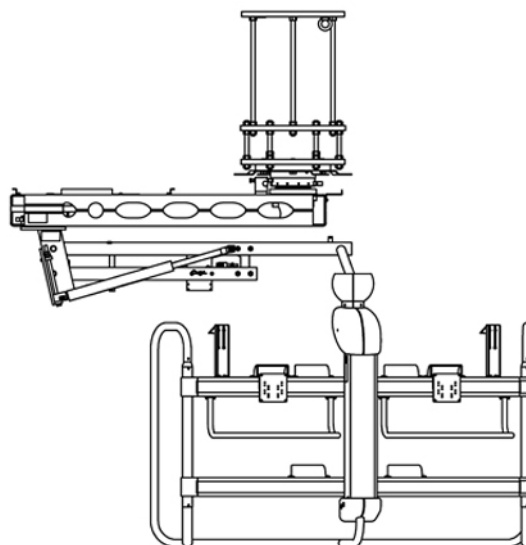

NOTICE

The Substructure for Dual Arm suspension is mandatory to install the MAVIG suspension with fixed point dual arm.

NOTICE

The lower edge of the Substructure for Dual Arm suspension should be the same height as the lower edge of the false ceiling.

2.3.3.4.2 Substructure for Dual Arm suspension

The Substructure for Dual Arm suspension is used to attach the MAVIG suspension with fixed point dual arm to the solid ceiling. It is used as the bridging element between the solid ceiling and the false ceiling for the installation and the fixation of the suspension.

Also, it provides a hooking point required for the installation and the replacement of the Large Display Monitor.

The Substructure for Dual Arm suspension is mandatory to install the MAVIG suspension with fixed point dual arm for Non-seismic Zones. For Seismic Zone installations, refer to Structural Engineer for appropriate design of the structure for installing the MAVIG suspension system.

For standard site configurations, the distance between the ceiling and the lower edge of the false ceiling should be in a range of minimum 175 mm and maximum 610 mm.

If the distance between the ceiling and the false ceiling is less than 175 mm, then the middle plate is not installed.

- Distance between ceiling and false ceiling: Minimum is 175 mm and maximum is 610 mm

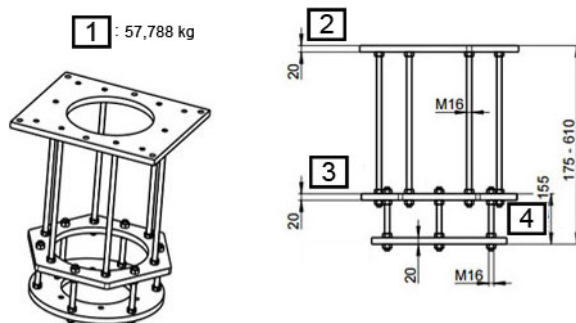

- Distance between ceiling and false ceiling: Less than 175 mm

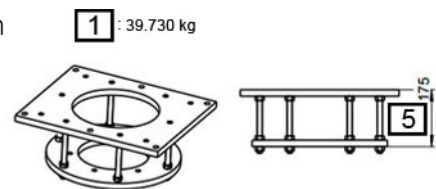

Item	Description
[1]	Weight in kg
[2]	Ceiling Plate

(continued)	
Item	Description
[3]	Middle Plate
[4]	Maximum is 155 mm
[5]	Maximum is 175 mm

The Substructure for Dual Arm suspension is delivered with each system. In the GEHC system catalogue (Pre-Installation item), its purchase number is **S18391MX** (MAVIG Purchase number GD60D022).



NOTICE

If the distance between the ceiling and the lower edge of the false ceiling is more than 610 mm, Long variation of the Substructure for Dual Arm suspension solution could be proposed by MAVIG.

2.3.3.4.2.1 Substructure mounting

The length of the Substructure for Dual Arm suspension S18391MX can be adapted to any individual situation (distance between solid ceiling and the lower edge of the false ceiling).

Length calculation and adaptation instruction are provided in the MAVIG substructure assembly instructions DBF0100X (where X may be 1 or higher).

The Substructure for Dual Arm suspension must be fastened to the ceiling using six suitable screws.

These screws must be dimensioned according to the conditions of the ceiling and provided by the customer and must be checked by the structural engineer.

The ceiling plate (2.1.3 Dimension Drawings on page 37) must be seated flush to the ceiling in order to ensure optimum load distribution.

The lower edge of the Substructure for Dual Arm suspension (interface plate [1]) should be the same height as the lower edge of the false ceiling [2].

Figure 79 False ceiling alignment versus interface plate

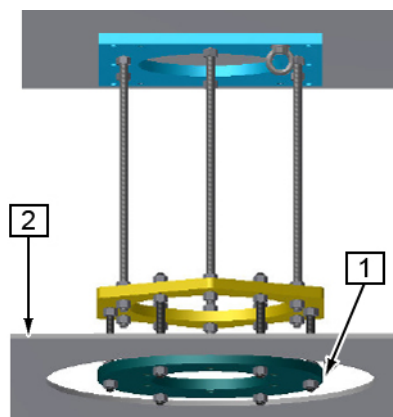

2.3.3.4.2.2 Bolt Specifications

The Substructure shall be fastened to the ceiling with following specifications:

The maximum axial load per bolt will not exceed 7210 N.

The maximum Shear load per bolt will not exceed 957 N.

The maximum pullout force shall be calculated in accordance with local building codes and it is part of structural analysis done by customer.

2.3.3.4.2.3 False ceiling specifications

The false ceiling should include an opening around the interface plate to allow service engineers to install and replace the suspension and the Large Display Monitor.

The diameter of the opening should be in the range of 489-620 mm (Figure 80 on page 111).

A trapdoor in the false ceiling should be provided to allow service access for cables management after mechanical installation of the suspension.

The distance between the substructure and the trapdoor should be less than 50 cm.

Figure 80

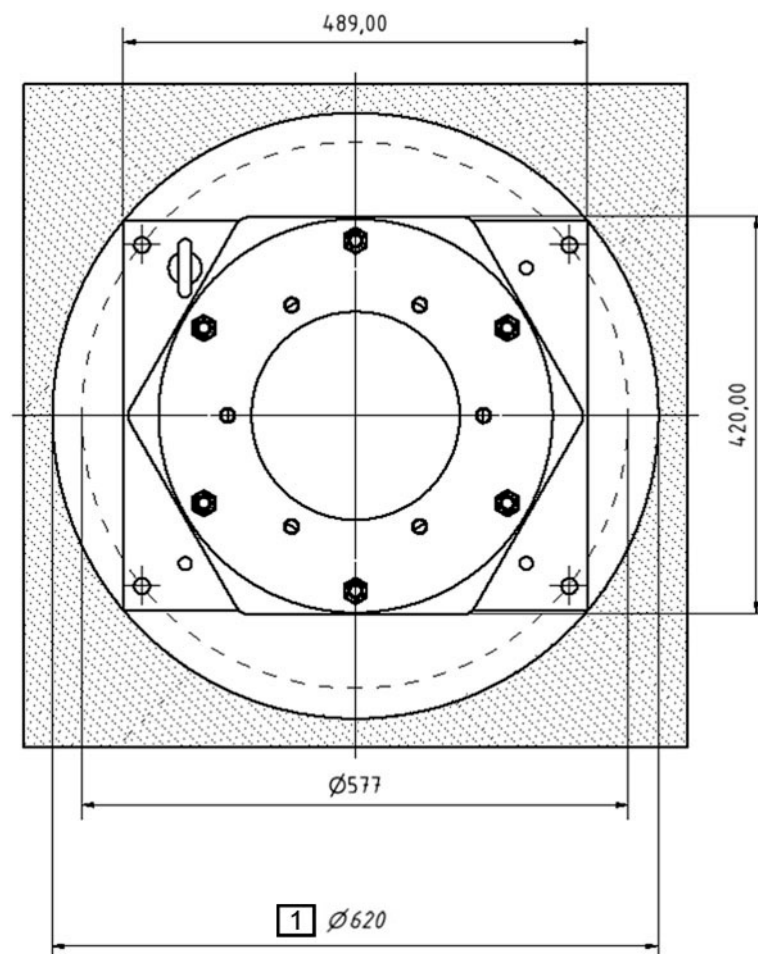

[1] : Port diameter of the false ceiling: maximum is 620 mm.

2.3.4 Wall Requirements

The optional LD secondary monitor outside the patient room is mounted on wall. The swingout arm that holds the LD additional monitor shall be mount according to the manufacturer mounting manual, see *Articulating Arm Wall Mount Installation Manual* in *OEM manuals list*.

An hooking point shall be provided in order to uplift the LD additional monitor at the swingout arm level during its installation:

- Hooking point characteristic: It must withstand up to 440 lbs (200 Kgs)
- Hooking point position:

Figure 81 Hooking point position

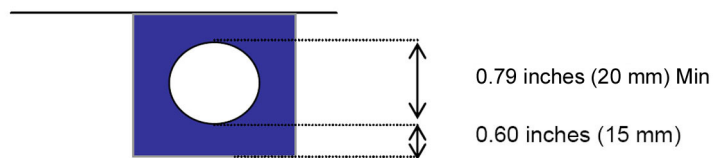

- Recommended hooking point dimensions:

Figure 82 Hooking point dimensions

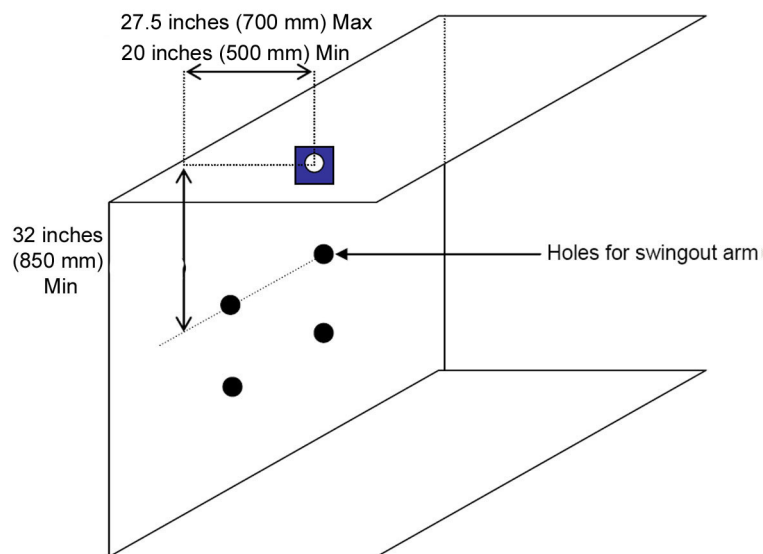

The position of the Swing out arm Center of Gravity (with weights) is given below.

Figure 83 Swing out arm Center of Gravity

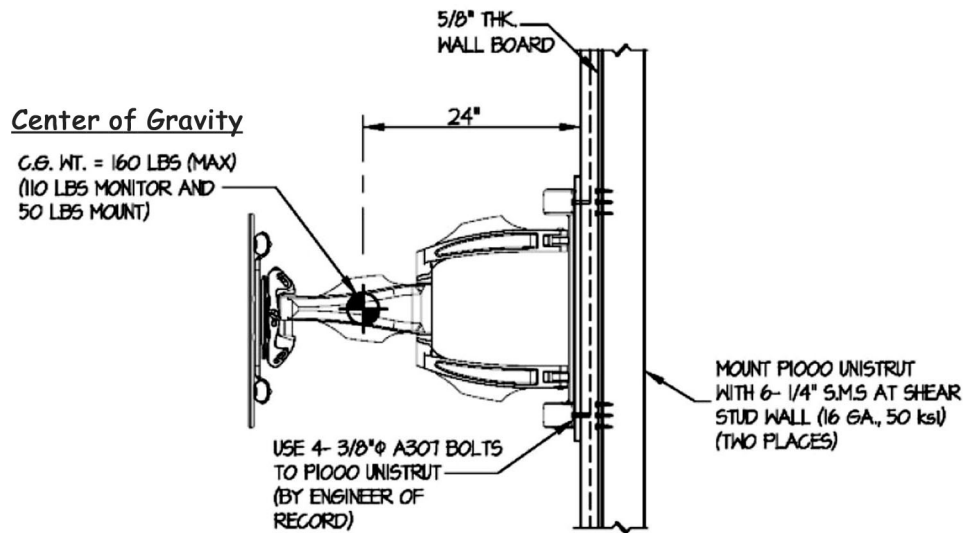

2.4 Seismic

2.4.1 Seismic areas

2.4.1.1 Floors

Chiller: The seismic kit for both Chillers SMC is included with the chiller when shipped..

LD cabinet : the seismic kit to fasten the LD cabinet to the wall is included with the cabinet when shipped.

In Seismic areas all cabinets must be anchored to the floor. See [2.1.5 System Compatibility on page 69](#) for referential documents. Frontal C1, Lateral C1 & C2 Cabinets: Wall support 2285242.

Every sub-system is delivered on site with its proper seismic kit.

- Monitor Flat Panel Seismic Kit: 2353317
- VCIM seismic kit: 2365510.

2.4.1.2 Walls

Anti-seismic means be installed before opening the system for normal use.

The C1 Cabinets, the C2 Cabinet, the PDB Cabinet and LD cabinet (optional) must be securely fastened to the wall and with their seismic kit to prevent them from tipping.

Consider local seismic codes when planning cabinet mounting. Consult seismic expert to determine which mounting method is appropriate for the seismic region. Certain seismic regions require additional reinforcement in walls. See [2.1.5 System Compatibility on page 69](#) for referential documents.

2.4.2 Seismic Calculations

Seismic requirements are determined and specified by the hospital/ Design Professional of record and may require approval by the specific state or country agency.

Seismic attachment hardware shown on seismic calculations may differ from hardware supplied with system. Any additional hardware that is required will be the responsibility of the institution and/or their contractor. Contact your local GE Installation Program Manager to obtain seismic calculations.

Seismic calculations are per California Building Code (CBC) and International Building Code (IBC).

2.4.2.1 Large Display Monitor suspension with fixed point dual arm



THE STANDARD SUBSTRUCTURE (MAVIG GD60D022) SHOULD NOT BE USED WITH SYSTEM IN SEISMIC ZONE.

Contact MAVIG or local contractor to design and supply specific substructure including M12 threaded holes requirement (see below).

Four M12 threaded holes with hooking point are required for the installation of the dual arm suspension, the installation and replacement of the Large Display Monitor. The structural support plate ([Figure 84 on page 115](#)) should include these 4 x M12 threaded holes.

For the threaded holes positioning on the structural support plate refer to [Figure 37 on page 55](#) in *Dimension Drawings*.

Figure 84 Center of gravity and seismic support, and attachments

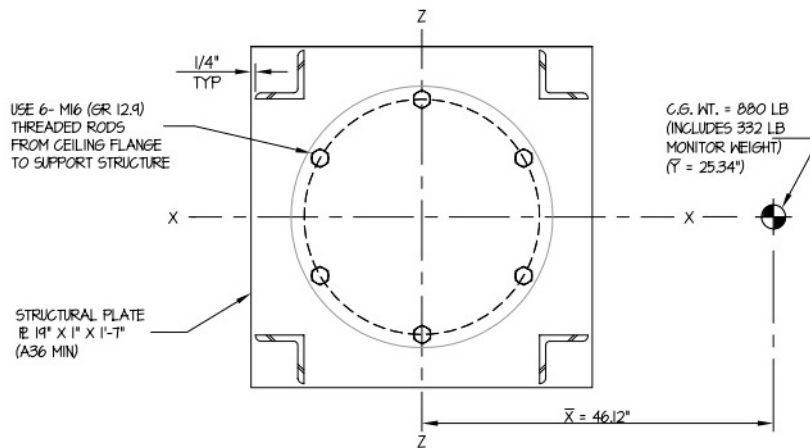
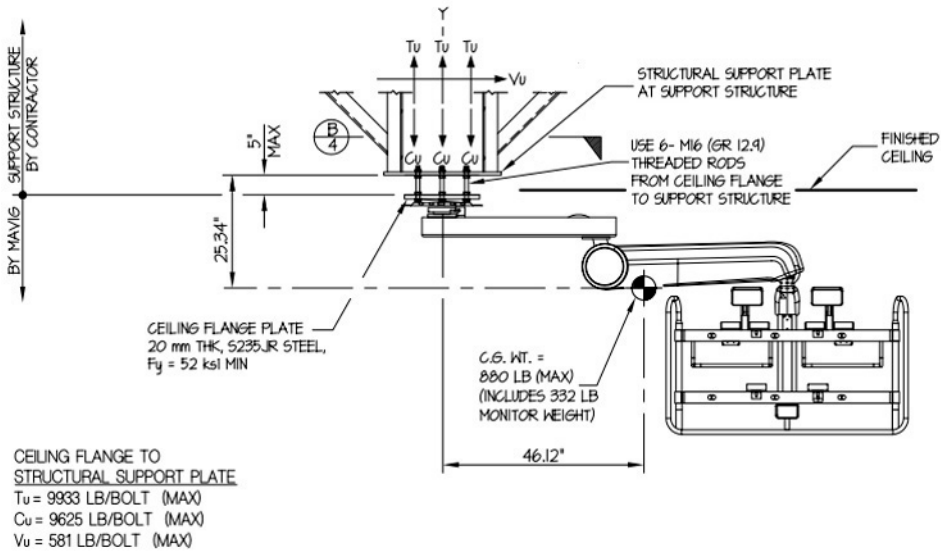

Page intentionally left blank

Chapter 3 Special Construction Requirements

3.1 Radiation Protection

Because x-ray equipment produces radiation, special precautions may be needed or special site modifications may be required. The General Electric Company does not make recommendations regarding radiation protection. It is the purchasers' responsibility to consult a radiation physicist for advise on radiation protection in x-ray rooms.

3.2 EMI Consideration

IEC60601-1-2 Electromagnetic Standard Compliance & Documentation

The information contained in this section is also found in the Innova system Operator Manual.

3.2.1 General Scope

This equipment complies with IEC-60601-1-2: Edition 2.1, Edition 3 and Edition 4 EMC standard for medical devices.

The Innova system is intended to be used:

- in a PROFESSIONAL HEALTHCARE facility environment and
- in a SPECIAL ENVIRONMENT for systems OR configurations (vicinity of active HF SURGICAL EQUIPMENT – refer to Installations Requirements & Environment Control).

The Innova system is suitable to be used in the electromagnetic environment, as per the limits & recommendations described in the tables here after:

- Emission Compliance level & limits ([Table 21 on page 118](#)).
- Immunity Compliance level & recommendations to maintain equipment clinical utility (see [Table 22 on page 119](#), [Table 23 on page 120](#) and [Table 26 on page 123](#)).

NOTE

The Innova system complies with above-mentioned EMC standard when used with supplied cables up to maximum lengths referenced in the MIS MAPS or system cables interconnect diagrams.

3.2.2 Electromagnetic Emission

The Innova system is intended for use in the electromagnetic environment specified below.

The purchaser or user of the Innova system should assure that it is used in such an environment.

Table 21

Emissions	Test Compliance	Electromagnetic Environment
Radio-Frequency emissions CISPR11	Group1 Class A limits ⁽¹⁾	<p>The system uses Radio Frequency energy only for its internal function. Therefore, its Radio Frequency emissions are very low and are not likely to cause any interference in nearby electronic equipment.</p> <p>The system is suitable for use in all establishments other than domestic and those directly connected to the public low voltage power supply network that supplies buildings used for domestic purposes.</p>
Harmonic emissions IEC 61000-3-2	Not applicable	The system is suitable for use in all establishments other than domestic and those directly connected to the public low voltage power supply network that supplies buildings used for domestic purposes.
Voltage fluctuations / flicker emissions IEC 61000-3-3	Not applicable	The system is suitable for use in all establishments other than domestic and those directly connected to the public low voltage power supply network that supplies buildings used for domestic purposes.
<p>NOTE</p> <p>⁽¹⁾ The EMISSIONS characteristics of this equipment make it suitable for use in industrial areas and hospitals (CISPR 11 class A). If it is used in a residential environment (for which CISPR 11 class B is normally required) this equipment might not offer adequate protection to radio-frequency communication services. The user might need to take mitigation measures, such as relocating or re-orienting the equipment.</p>		

3.2.3 Electromagnetic Immunity

3.2.3.1 Electromagnetic Immunity IEC 60601-1-2

The Innova system is intended for use in the electromagnetic environment specified below.

The purchaser or user of the Innova system should assure that it is used in such an environment.

Table 22

Immunity Test	IEC 60601-1-2 Ed2.1 & 3 Test Level	IEC 60601-1-2 Ed4 Test Level (professional healthcare environment)	Compliance Level	Electromagnetic Environment
Electrostatic discharge (ESD) IEC 61000-4-2	+/-6 kV contact +/-8 kV air	+/-6 kV contact +/-8 kV air	+/-6 kV contact +/-8 kV air	Floors are wood, concrete, or ceramic tile, or floors are covered with synthetic material and the relative humidity is at least 30 %.
Electrical fast transient/burst IEC 61000-4-4	+/-2 kV for power supply lines +/-1 kV for input/output lines 5 kHz burst repetition frequency	+/-2 kV for power supply lines +/-1 kV for input/output lines 100 kHz burst repetition frequency	+/-2 kV for power supply lines +/-1 kV for input/output lines 5 kHz & 100 kHz burst repetition frequency	Mains power quality is that of a typical commercial or hospital environment.
Surge IEC 61000-4-5	+/-1 kV line(s) to lines(s) +/-2 kV line(s) to earth	+/-1 kV line(s) to lines(s) +/-2 kV line(s) to earth	+/-1 kV line(s) to lines(s) +/-2 kV line(s) to earth	Mains power quality is that of a typical commercial or hospital environment.
Voltage dips, short interruptions and voltage variations on power supply input lines IEC 61000-4-11	< 5% U_T (>95% dip in U_T) 0% for 5sec	0 % U_T 250/300 cycle	< 5% U_T (>95% dip in U_T) 0% for 5sec 0% U_T 250/300 cycle	Mains power quality is that of a typical commercial or hospital environment. If the user of the Innova system requires continued operation during power mains interruptions, it is recommended that the Innova system be powered from an uninterruptible power supply.
Power frequency (50/60 Hz) magnetic field IEC 61000-4-8	3 A/m		3 A/m	Power frequency magnetic fields are at levels characteristic of a typical location in a typical commercial or hospital environment.
Note: U_T is the mains voltage prior to application of the test level. 250/300 cycle means 250 periods at 50Hz or 300 periods at 60Hz				

The Innova system is intended for use in the electromagnetic environment specified below.
 The purchaser or user of the Innova system should assure that it is used in such an environment.

Table 23

Immunity Test	IEC 60601-1-2 Ed2.1 & 3 Test Level	IEC 60601-1-2 Ed4 Test Level (professional healthcare environment)	Compliance Level	Electromagnetic Environment
Conducted Radio Frequency IEC 61000-4-6	3 Vrms 150 kHz to 80 MHz	3 Vrms 150 kHz to 80 MHz 6Vrms in ISM bands ⁽¹⁾	$V_1 = 3 \text{ V}^{(1)}$	Portable and mobile RF communications equipment is used no closer to any part of the system, including cables, than the recommended separation distance calculated from the equation applicable to the frequency of the transmitter.
Radiated Radio Frequency IEC 61000-4-3	3 V/m 80 MHz to 2.5 GHz	3 V/m 80 MHz to 2.7 GHz	$E_1 = 3 \text{ V/m}^{(4)}$	<p>Recommended separation distance: $d = [3.5/V1]\sqrt{P}$ $d = [3.5/E1]\sqrt{P}$, from 80 MHz to 800 MHz $d = [7/E1]\sqrt{P}$, from 800 MHz to 2.5 GHz</p> <p>Where P is the maximum output power rating of the transmitter in watts (W) according to the transmitter manufacturer and d is the recommended separation distance in meters (m).</p> <p>Field strengths from fixed RF transmitters, as determined by an electromagnetic site survey⁽²⁾, are less than the compliance level in each frequency range⁽³⁾.</p> <p>Interference may occur in the vicinity of equipment marked with the following symbol:</p> 

NOTE

⁽¹⁾: The ISM (industrial, scientific and medical) bands between 0,15 MHz and 80 MHz are 6,765 MHz to 6,795 MHz; 13,553 MHz to 13,567 MHz; 26,957 MHz to 27,283 MHz; and 40,66 MHz to 40,70 MHz

⁽²⁾: Field strengths from fixed transmitters, such as base stations for cellular telephones and land mobile radios, amateur radio, AM and FM radio broadcast, and TV broadcast cannot be theoretically estimated accurately. To assess the electromagnetic environment due to fixed RF transmitters, an electromagnetic site survey should be performed. If the measured field strength exceeds the RF compliance level above, observe the Innova system to verify normal operation in each use location. If abnormal performance is observed, additional measures may be necessary, such as re-orienting or relocating the Innova system.

⁽³⁾: Over the frequency range 150 kHz to 80 MHz, field strengths are less than 3 V/m.

⁽⁴⁾: Refer to table & warning below:



THE INNOVA IGS SYSTEM IS A LARGE, PERMANENTLY-INSTALLED MEDICAL EQUIPMENT FOR WHICH THE SIMULATED OPERATION IN AN ANECHOIC CHAMBER IS NOT FEASIBLE AND CONSEQUENTLY IS EXEMPT FROM THE TESTING REQUIREMENT SPECIFIED BY IEC 61000-4-3.

THE INNOVA SYSTEM HAS NOT BEEN TESTED FOR RADIATED RF IMMUNITY OVER THE ENTIRE FREQUENCY RANGE 80 MHZ TO 6 GHZ.

THE INNOVA SYSTEM HAS BEEN TESTED FOR RADIATED RF IMMUNITY ONLY AT SELECTED FREQUENCIES, AND USE NEARBY OF EMITTERS AT OTHER FREQUENCIES COULD RESULT IN IMPROPER OPERATION.

Table 24 IEC60601-1-2 ed2.1 &3 field level & frequencies

Tested Frequencies (MHz)	Field Level (V/m)	Modulation
433.920 (ISM) ⁽¹⁾	3	80% AM at 1 kHz rate
915 (ISM) ⁽¹⁾		
1440		
1750		
1920		
2450 (ISM) ⁽¹⁾		

NOTE

⁽¹⁾: Industrial, Scientific and Medical (ISM) radio bands.

The associated recommended separation distances as per IEC60601-1-2 ed2.1 & 3 are listed in [Table 26 on page 123](#).

Table 25 Additional IEC60601-1-2 ed4.0 field level & frequencies - immunity to proximity fields from RF wireless equipment

Tested frequencies (MHz)	Field Level (V/m)	Modulation
385	27	Pulse modulation (50% duty cycle) - 18Hz
450	28	Pulse modulation (50% duty cycle) - 18Hz
710	9	Pulse modulation (50% duty cycle) - 217Hz
710	9	Pulse modulation (50% duty cycle) - 217Hz
745	9	Pulse modulation (50% duty cycle) - 217Hz
780	9	Pulse modulation (50% duty cycle) - 217Hz
810	28	Pulse modulation (50% duty cycle) - 18Hz
870	28	Pulse modulation (50% duty cycle) - 18Hz
930	28	Pulse modulation (50% duty cycle) - 18Hz
1720	28	Pulse modulation (50% duty cycle) - 217Hz
1845	28	Pulse modulation (50% duty cycle) - 217Hz
1970	28	Pulse modulation (50% duty cycle) - 217Hz
2450 (ISM) ⁽¹⁾	28	Pulse modulation (50% duty cycle) - 217Hz
5240	9	Pulse modulation (50% duty cycle) - 217Hz
5500	9	Pulse modulation (50% duty cycle) - 217Hz
5785	9	Pulse modulation (50% duty cycle) - 217Hz
5800(ISM) ⁽¹⁾	9	Pulse modulation (50% duty cycle) - 217Hz

NOTE

⁽¹⁾ Industrial, Scientific and Medical (ISM) radio bands.

Equipment used for tests:

- RF signal generator,
- RF power amplifier,
- Transmitting antenna,
- Field sensor,
- Field meter.



PORTABLE RF COMMUNICATIONS EQUIPMENT INCLUDING PERIPHERALS (SUCH AS ANTENNA CABLES AND EXTERNAL ANTENNAS) SHOULD BE USED NO CLOSER THAN 30CM (12 INCHES) TO ANY PART OF THE SYSTEM INCLUDING CABLES SPECIFIED BY THE MANUFACTURER.

OTHERWISE, DEGRADATION OF THE PERFORMANCE OF THIS EQUIPMENT COULD RESULT.

3.2.3.2 Recommended Separation Distances for Portable and Mobile RF Communications Equipment IEC 60601-1-2 (Ed2.1&3)

Table 26

Frequency of Transmitter	150 KHz to 80 MHz	80 MHz to 800 MHz	800 MHz to 2.5 GHz
Equation	$d = [3.5 / V_1] \sqrt{P}$	$d = [3.5 / E_1] \sqrt{P}$	$d = [7 / E_1] \sqrt{P}$
Rated Power of Transmitter (watts)	Distance (meters)	Distance (meters)	Distance (meters)
0.01	0.11	0.11	0.22
0.1	0.37	0.37	0.74
1	1.1	1.1	2.3 (*)
10	3.7	3.7	7.4
100	12	12	23

For transmitters rated at a power not listed above, the DISTANCE can be estimated using the equation in the corresponding column, where P is the power rating of the transmitter in watts (W) according to the transmitter manufacturer.

NOTE

These are guidelines. Actual conditions may vary.

3.2.4 Limitations Management

Adhering to the distance separation recommended in [Table 26 on page 123](#), between 150 kHz and 2.5 GHz, will reduce disturbances recorded at the image level, but may not eliminate all disturbances. However, when installed and operated as specified herein, the Innova system will maintain its essential performance by continuing to acquire, display, and store diagnostic quality images safely.

For example, a 1 W mobile phone (800 MHz to 2.5 GHz carrier frequency) shall be put 2.3 meters (see (*) [Table 26 on page 123](#)) apart from the Innova system (in order to avoid images interferences risks).

3.2.5 Installations Requirements & Environment Control



THE USE OF ACCESSORIES, TRANSDUCERS, AND CABLES OTHER THAN THOSE SPECIFIED MAY RESULT IN DEGRADED ELECTROMAGNETIC COMPATIBILITY OF THE INNOVA SYSTEM.

Other electrical equipment may disturb and interfere with these Innova components. The control of the clearing distances from the noise sources is recommended, power supplies converters from nearby monitors or from other close electrical equipment). Refer to respective device manufacturers instructions & recommendations in such cases.



In order to minimize interference risks, the following requirements shall apply:

- **Cables shielding & grounding:**
All interconnect cables to peripheral devices must be shielded and properly grounded. Use of cables not properly shielded and grounded may result in the equipment causing radio frequency interference.
- **Power supply distribution panel & power line:**
The Innova system is predominantly intended for use (e.g. in hospitals) with a dedicated supply system, and with an X-Ray shielded room.
- **Subsystems, options & accessories Power supply distribution:**
All components, accessories subsystems, systems which are electrically connected to the Innova system, have to be all AC power supplied by the same power distribution panel & line.

NOTE

In order to avoid interferences, the same AC power distribution panel should supply all Innova system components, accessories, subsystems and options as the Advantage Workstation, and the UPS. That same AC power distribution panel should be supplied by a separated AC power line (coming from a separated transformer line and winding).

- **Stacked components & equipment:**
The Innova system should not be used adjacent to or stacked with other equipment; if adjacent or stacked use is necessary, the Innova system should be observed to verify normal operation in the configuration in which it will be used.
- **Low frequency magnetic field:**
In case of an Innova system, the Gantry (digital detector) shall be apart 1 meter from the X-Ray generator cabinet, 1 meter from the PDU cabinet, 3 meters from the UPS cabinet, and 1 meter apart from monitors. These distances specifications shall minimize the low frequency magnetic field interference risk.
- **Electrostatic discharges environment & recommendations:**
 - In order to reduce electrostatic discharge interference, install a charge dissipative floor material to avoid electrostatic charge buildup.
 - The relative humidity shall be at least 30 percent.
 - The dissipative material shall be connected to the system ground reference, if applicable.

Page intentionally left blank

Chapter 4 Environmental Requirements

4.1 Relative Humidity and Temperature



NOTICE

Avoid extremes in temperatures

Innova system room climate requirements – relative humidity and temperature. Individual products or components are classed by their installation area for **in use** see [Table 27 on page 127](#),

Individual products or components are classed separately for **Storage**, see [1.4 Product Storage and Handling Requirements on page 24](#).

NOTE

Due to the differential in temperature / humidity between the clinical room and the room below, the floor creates condensation within the gantry / patient table resulting in part failure or rusting inside the gantry / patient table.

For systems that are planned to be installed on higher level (second floor or above), the temperature and humidity of the rooms that are directly below the gantry room should be maintained same as the exam room requirement. Failure to do so will void the equipment warranty. Avoid above grade installations where the temperature is high in the area below the gantry / table cables exit if at all possible.

Table 27 In use - Humidity and Temperature

INSTALLATION ROOM OF PRODUCT OR COMPONENT	RELATIVE HUMIDITY (NON-CONDENSING)		TEMPERATURE			
	IN-USE		IN-USE (See Note (2a))		RECOMMENDED (See Note (2b))	
	MIN	MAX	MIN	MAX	MIN	MAX
Examination room	30%	70%	+15°C +59°F	+32°C +90°F	Design for Patient/ Operator Comfort	
Technical room (See Note (1))	30%	75%	+10°C +50°F	+32°C +90°F	+13°C +55°F	+25°C +77°F
Technical room with Fluoro UPS optional	30%	75%	+20°C +68 °F	+25°C +77°F	+20°C +68 °F	+25°C +77°F
Control room	30%	75%	+15°C +59°F	+35°C +95°F	+20°C +68°F	+25°C +77°F

NOTE

(1): The target temperature (best recommended) is 18°C (64°F).

The target humidity (best recommended) is 50% RH.

NOTE

(2a): **In use temperature limits** specify the range where the system shall work. Operating outside these limits could occur severe performance and reliability issues.

(2b): **Recommended temperature limits** specify the range where it is recommended to adjust air conditioning control in order to warranty current operations inside the in use range.

Relative Humidity and Temperature: Refer to [Table 27 on page 127](#). To obtain relative humidity and temperature requirements for components not specified in [Table 27 on page 127](#), refer to the appropriate component Pre-Installation Manual listed in [2.1.5 System Compatibility on page 69](#).



NOTICE

In some cases condensation occurs and water drops from outlets and pipes of the air conditioner in the technical room.

Therefore, it is critical to install the cabinets where there is no risk of flood from the air conditioner.

4.2 Altitude and Atmospheric Pressure

Refer to [Table 28 on page 128](#). To obtain altitude and atmospheric pressure requirements for components not specified in [Table 28 on page 128](#), refer to the appropriate component Pre-Installation Manual listed in [2.1.5 System Compatibility on page 69](#).

For storage and transport, individual products or components are classed separately, refer to [1.4 Product Storage and Handling Requirements on page 24](#).

Table 28 Altitude and Atmospheric Pressure

INSTALLATION ROOM OF PRODUCT OR COMPONENT	ALTITUDE (meters)		ATMOSPHERIC PRESSURE (kPa)	
	IN-USE		IN-USE	
	MIN	MAX	MIN	MAX
Examination room	0	3000	70	106
Technical room	0	3000	70	106
Control room	0	3000	70	106

4.3 Heat Output

4.3.1 Equipment Heat Output Tables

Refer to [Table 29 on page 129](#). To obtain heat output information for components not specified in [Table 29 on page 129](#), refer to the appropriate component Pre-Installation Manual listed in [2.1.5 System Compatibility on page 69](#).

Table 29

		HEAT OUTPUT							
		Stand by		Moderate Use (8 cases / a 10 hour day)		Typical Use (13 cases / a 10 hour day)		Maximum Use (maximum peak power during exam)	
Room	Core System	kW	BTU/hr	kW	BTU/hr	kW	BTU/hr	kW	BTU/hr
Exam Room	Innova Frontal/Lateral positioner and table	0.61	2076	0.75	2540	1.21	4128	1.62	5517
Ctrl Room	DL user area with 1 TFT monitor	0.16	546	0.16	546	0.16	546	0.16	546
	3 B&W flat monitors	0.25	859	0.25	859	0.25	859	0.25	859
	Ctrl Room Total	0.41	1405	0.41	1405	0.41	1405	0.41	1405
Tech Room	C1 Frontal Cabinet	0.71	2421	0.99	3389	1.29	4412	1.59	5435
	C1 Lateral Cabinet	0.31	1057	0.56	1923	0.86	2946	1.16	3969
	C2 Cabinet	0.29	989	0.83	2813	1.34	4571	1.81	6171
	Coolix 4100 chiller Frontal & Lateral @ 50Hz (1) (2)	1.55	5288.6	2.1	7165	2.72	9280.64	5.5	18766
	Coolix 4100 chiller Frontal & Lateral @ 60Hz (1) (2)	2.32	7915.84	2.8	9553	3.44	11737.28	6.3	21495.6
	Chiller autotransformer @ 50Hz	0.04	136.48	0.048	164	0.045	153.54	0.065	221.78
	Chiller autotransformer @ 60Hz	0.06	204.72	0.064	218	0.07	238.84	0.09	307.08
	Detector conditioner Frontal	0.21	709	0.21	709	0.21	709	0.21	709
	Detector conditioner Lateral	0.21	709	0.21	709	0.21	709	0.21	709

continued									
		HEAT OUTPUT							
		Stand by		Moderate Use (8 cases / a 10 hour day)		Typical Use (13 cases / a 10 hour day)		Maximum Use (maximum peak power during exam)	
Room	Core System	kW	BTU/hr	kW	BTU/hr	kW	BTU/hr	kW	BTU/hr
	Main disconnect panel PDB	0.60	2216	0.65	2216	0.65	2216	0.65	2216
	1kVA Cabinet UPS - model 9130	0.15	500	0.37	1257	0.37	1257	0.37	1257
	Tech Room Total	7.24	24842	12.29	41888	15	51153	19.65	67003
Total for core system		8.26	28323	13.44	45832	16.63	56685	21.68	73925
Room	Options (3)	Stand by		Moderate Use		Typical Use		Maximum Use	
Exam Room	7 in room B&W TFT monitors	0.59	2005	Same values as Stand by		Same values as Stand by		Same values as Stand by	
	In room AW TFT monitor	0.12	409						
	Typical injector	0.09	320						
	LD Monitor	0.5	1706						
	Exam room total	1.3	4440						
Ctrl Room	AW work station	0.35	1201						
	2 AW TFT monitors	0.24	818						
	Printer	0.31	1054						
	LD Monitor (4)	0.5	1706						
	Ctrl room total	1.4	4779						
Tech Room	LD Cabinet	1.0	3412						
	3kVA LDM UPS - model 9130	0.37	1257						
	Tech Room Total	1.37	4669						
Typical configuration without fluoro UPS		10.27	35173	15.15	51640	18.33	62493	23.39	79732
Note (1): Air flow requirements 1200 m ³ /h (706 CFM)									
Note (2): For more details, consult appropriate pre-installation manual									

continued									
		HEAT OUTPUT							
		Stand by		Moderate Use (8 cases / a 10 hour day)		Typical Use (13 cases / a 10 hour day)		Maximum Use (maximum peak power during exam)	
Room	Core System	kW	BTU/hr	kW	BTU/hr	kW	BTU/hr	kW	BTU/hr
Note (3): For UPS 20 kVA option refer to Fluoro UPS Option on page 131									
Note (4): The 2nd optional LD monitor is not necessarily in the control room. It may be installed in the exam room (outside patient vicinity).									



Make sure there is a ventilation air flow, preferably ensured by natural air flow, otherwise by enforced ventilation, so that hydrogen concentration is below 1% (according to Standard IEC 62040-1-2).

4.3.2 Fluoro UPS Option

Figure 85

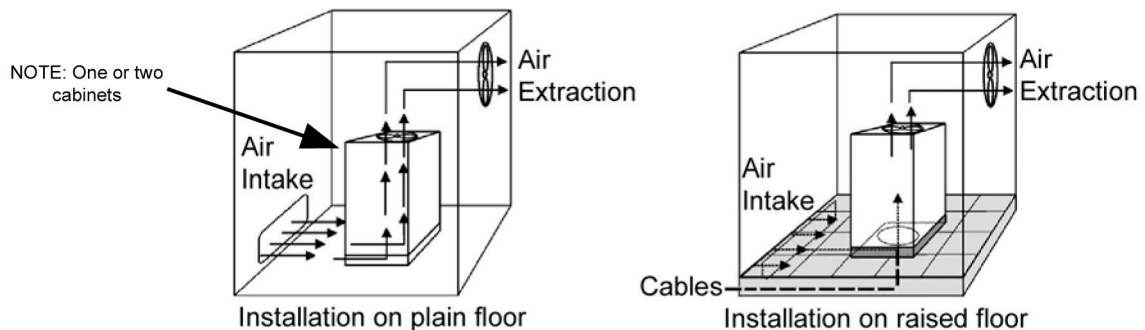

The heat produced by the UPS is transferred to the environment by its ventilation. Cooling air enters the cabinets through the air inlet (grids) located at the bottom and exhausted through the outlet on the roof. A suitable ventilation or cooling system must be installed to extract the heat from the UPS room.

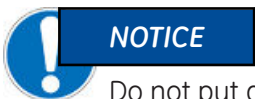

Do not put anything on the top of the cabinet.

If the UPS is placed on a raised floor, the airflow for UPS cooling should enter from underneath the UPS, through the appropriate aperture on the raised floor.

If the UPS runs in a dusty environment, we recommend strongly to install filters on the air inlet of the UPS room. In this case it should be considered that these filters can cause reduced speed at the air inlet.

The size of the air inlet has therefore to be dimensioned accordingly.

Contact your Local Distributor or one of the Service Centre, which will help you to find valuable solutions.

Table 30 on page 132 indicates the typical heat dissipation at nominal load and specify cooling air flow in two situations:

- 1000 m (3280 ft) altitude, cooling air between 25°C (77°F) and 30°C(86°F)
- 250 m (820 ft) altitude, cooling air below 18°C (64°F)

Table 30

Fluoro UPS	Typical heat output	On-line cooling air flow at 30°C / 86°F	Typical on-line cooling air flow at 18°C / 64°F
CE version	1.50 kW (5101 BTU/hr)	625 m ³ /h (368 CFM)	227 m ³ /h (134 CFM)
UL version	4720 BTU/hr (1.38 kW)	301 CFM (511 m ³ /h)	119 CFM (203 m ³ /h)

4.4 Acoustic Specifications

Audible noise:

- Less than 50 dB (A) at 1 meter for an Innova Frontal Positioner.
- Less than 50 dB (A) at 1 meter for an Innova Lateral Positioner.
- Limited to 50 dB (A) at 1 meter for Omega V table.
- Limited to 55 dB (A) at 1 meter for C2 Cabinet (Frontal/Lateral).
- Limited to 60 dB (A) at 1 meter for the Coolix 4100 chiller.
- Limited to 65 dB (A) at 1 meter for C1 Frontal Cabinet.
- Limited to 65 dB (A) at 1 meter for C1 Lateral Cabinet.
- Limited to 52 dB (A) (background of 35 dB (A)) at 1 meter for Digital Detector Conditioner Thermo-Con.
- Less than 50 dB (A) at 1 meter for a DL LCD monitor.
- Less than 50 dB (A) at 1 meter for the Fluoro UPS.

The values contained in Table 31 on page 132 are the results of the measurement performed on the first system with 31 cm Revolution Digital detector installed on a clinical site.

Table 31 Gantry Noise measurements

Measurements	Gantry (FRT, LAT, both)	Gantry positions	Peak (db)	Mean (db)
Ambient (System off)		1	N/A	55.7
System ON (no motion, no X-Ray)		2	N/A	58.2
Motions	FRT (Detector lift)	1	86.2	66.3
	LAT (C-Arc)	2	86.3	63.7
	FRT and LAT	2	85.1	66.9

Gantry Noise measurements continued				
Measurements	Gantry (FRT, LAT, both)	Gantry positions	Peak (db)	Mean (db)
First scopie (anode acceleration)	FRT	1	80.2	60.3
	LAT	2	80.3	59.6
Fluoro	FRT	1	79.7	59.2
	LAT	2	79.5	59.1
	FRT and LAT	2	79.8	60.2

NOTE

Noise generated by system cabinets all together is 70dB. If cabinets are installed too close to the exam room (e.g. behind sliding doors) appropriate measures have to be implemented during the pre-installation to effectively reduce noise in the exam room.

Page intentionally left blank

Chapter 5 Electrical Requirements

5.1 Power Requirements

5.1.1 Electrical Requirements

Innova System requires a specific power line, with three phase (see Illustration in [5.1.2 Power Distribution on page 139](#)).

Table 32 Core system

Nominal voltage	Frequency	Power consumption		Type of power input	
		Nominal (at 125 kV, 100 ms, 640 mA)	Peak	Without Fluoro UPS	With Fluoro UPS
380 V ± 10 %	50 Hz or 60 Hz (± 3 Hz)	60 kVA	150 kVA	3~	3N~
400 V ± 10 %					
415 V ± 10 %					
480 V ± 10 %	60 Hz (± 3 Hz)				

The Hospital circuit breaker should fit the current protection of the Innova system:

- 150A/ 480V, 3 Phases for UL
- 80A/ 380V/400V/415V, 3 Phases for CE

Table 33 Options

Option	Nominal voltage	Frequency	Nominal Power consumption	Type of power input
LDM	100-120 V / 220-240 V	50 Hz or 60 Hz (± 3 Hz)	3 kVA	Single phase
AW	100-127 V / 200-240 V	50 Hz or 60 Hz	11 A / 5.5 A	Single phase
S5I GE	100-120 V / 230 V	50 Hz or 60 Hz	400 VA	Single phase

NOTE

PDB maximum rating is equal to 211 kVA.

Large Display Option requires an additional power line for Large Display Cabinet (see illustration in [5.1.2 Power Distribution on page 139](#)).

This power line should fit the current protection requirement of Large Display Cabinet:

- 30A /120V / AWG10 (UL option)

- 30A /120V / AWG10 (CE option)



NOTICE

Line impedance should be compliant with IEC 601.2.7 Refer to the table **Max Line Impedance for feeder line between Generator cabinet and Hospital** in 5.2.2 Power and Grounding Requirements on page 152.



PRIOR TO EACH INSTALLATION, ENSURE THAT THE ECG POWER CABLE IS CONNECTED TO A LINE THAT IS PROTECTED AGAINST SHORT CIRCUIT HAZARDS, ACCORDING TO LOCAL REGULATIONS AND THAT THE ECG MONITOR IS POWERED ACCORDING TO IEC60601-1 REQUIREMENTS (LEAKAGE CURRENT AND GROUNDING).



NOTICE

When a Fluoro UPS is or will be installed, a Neutral line is mandatory. If IT scheme as earthing system is used, an isolation transformer is required with Delta-Wye or Delta-Star connection.

Optional Isolation transformer specifications:

It shall be :

- Secondary star 3Ph+N
- 150 kVA minimum for input voltage of 380V and 400V. 100 kVA minimum for input voltage of 415V and 480V
- Power distribution shall be of TNS type with Neutral grounded
- The transformer impedance shall be 4.5% or less (this parameter is also called %Z or short circuit voltage)

Figure 86 TNS scheme

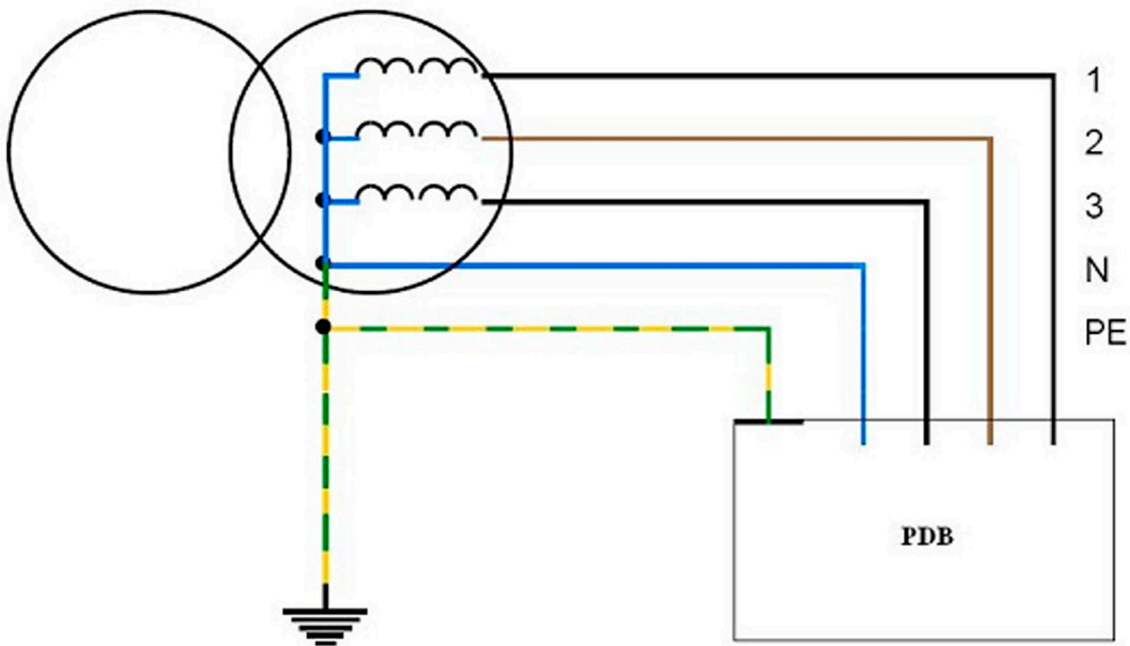

5.1.1.1 Power configuration for Coolix 4100 Chillers

Both frontal and lateral Coolix 4100 chillers are powered from 2 phase supply :

- 1st Chiller by phases L1 and L2
- 2nd Chiller by phases L1 and L3

Figure 87 Power configuration for Coolix 4100 Chillers

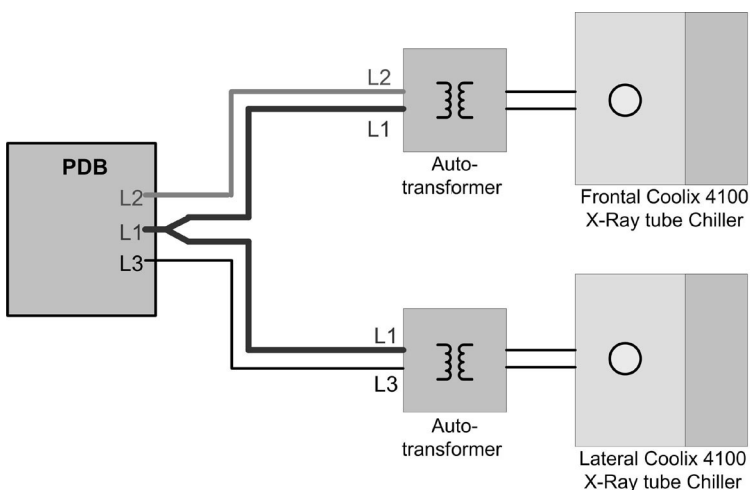

A non-continuity measurement must be made between phase L2 of the frontal autotransformer and phase L3 of the lateral autotransformer.

A continuity measurement must be made between phase L1 of the frontal autotransformer and phase L1 of the Lateral autotransformer.



MEASUREMENTS SHOULD BE PERFORMED ON A SYSTEM OFF.

5.1.1.2 Large Display Monitor System special instructions:



THERE IS A DANGER TO LIFE IF WARNINGS ARE NOT OBEYED. SEVERE PERSONAL INJURY OR DAMAGE TO EQUIPMENT MAY OCCUR.

DO NOT INSERT ANY OBJECTS INTO THE HOUSING.

OBJECTS INSERTED INTO THE HOUSING MAY RESULT IN DAMAGE TO THE UNIT OR PERSONAL INJURY. DO NOT PLACE ANY OBJECTS ON TOP OF THE LARGE DISPLAY CABINET. LIQUID ENTERING THE UNIT MAY RESULT IN FIRE OR ELECTRIC SHOCK.

Backup power instructions:

The Large Display subsystem is powered by the Hospital mains single phase electrical power. It is not supplied by the Fluoro UPS in case of power outage, but by its own 3kVA UPS.

5.1.1.3 Customer Requirements:

- Large Display Option:
 - The customer shall provide the power supply cables between the transformer and the UPS of the LD cabinet (for LD system option).
 - The LDM optional system must be powered through a wall circuit breaker or equivalent device with LOTO capability. This circuit breaker must have a 30 amps current rating. Procurement, delivery and installation of this device is customer responsibility.
- The customer shall provide Power supply cables between the main transformer and the system:
 - Main supply: 3 phases + 1 ground (+ 1 neutral if Fluoro UPS option present)
 - Cables from PDB to Jedi (LAT and FRT)
 - Cables from PDB to Tube Chillers (LAT and FRT)
 - Cable from PDB to modular PDU inside C2 cabinet
 - Cable from PDB to the fluoro UPS
- **Injectors:** If Injector is not powered by the PDB, it is the customer responsibility to ensure the compliance of installation by referring to injector's documentation.

5.1.2 Power Distribution

NOTE

All short AC power cable less than 3 meters, between peripherals and respective power strip, are not shown. All have a single phase line, a neutral line and a ground wire.

NOTE

Large Display Cabinet can provide power to an optional secondary large monitor outside of the patient vicinity.

Figure 88 Power distribution - CE

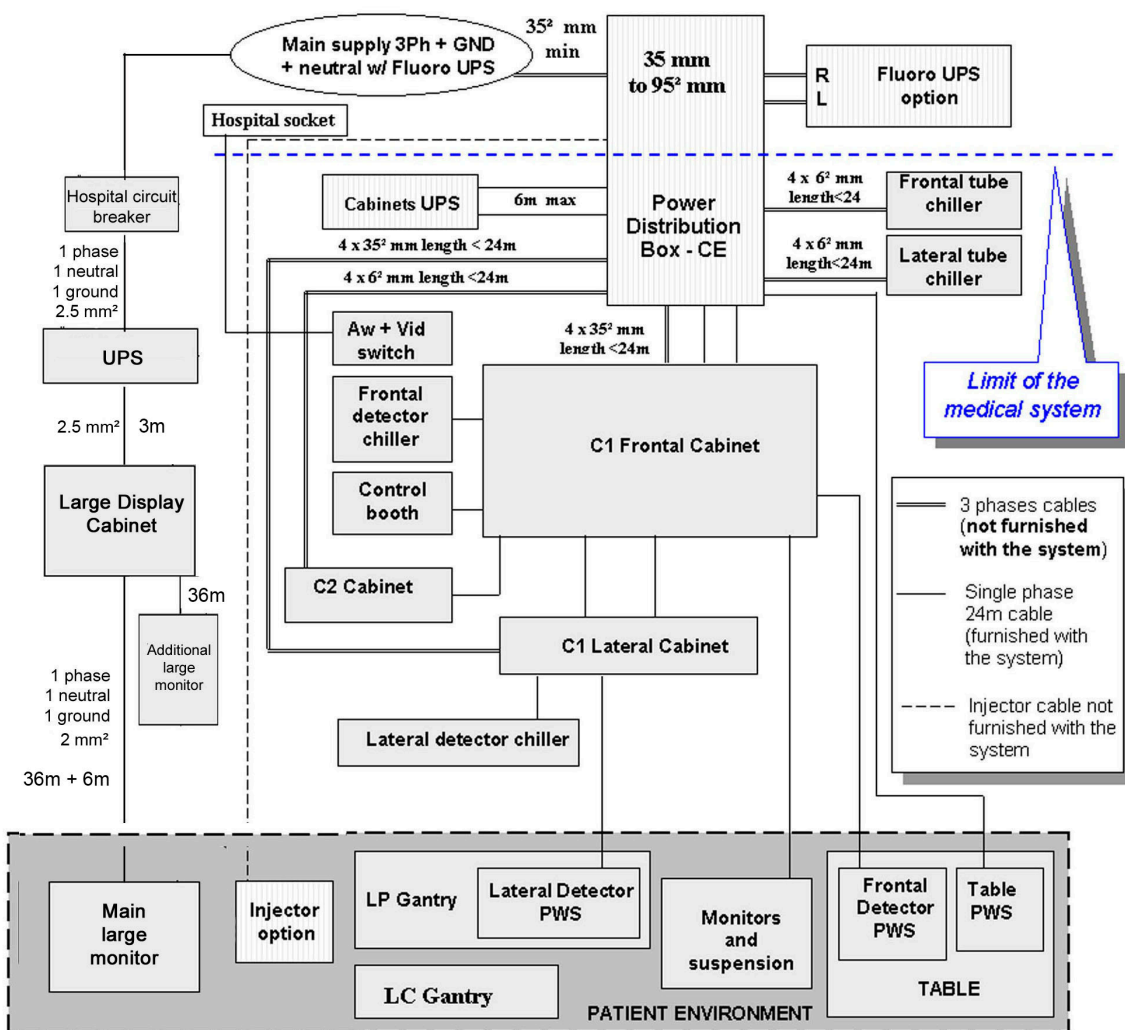
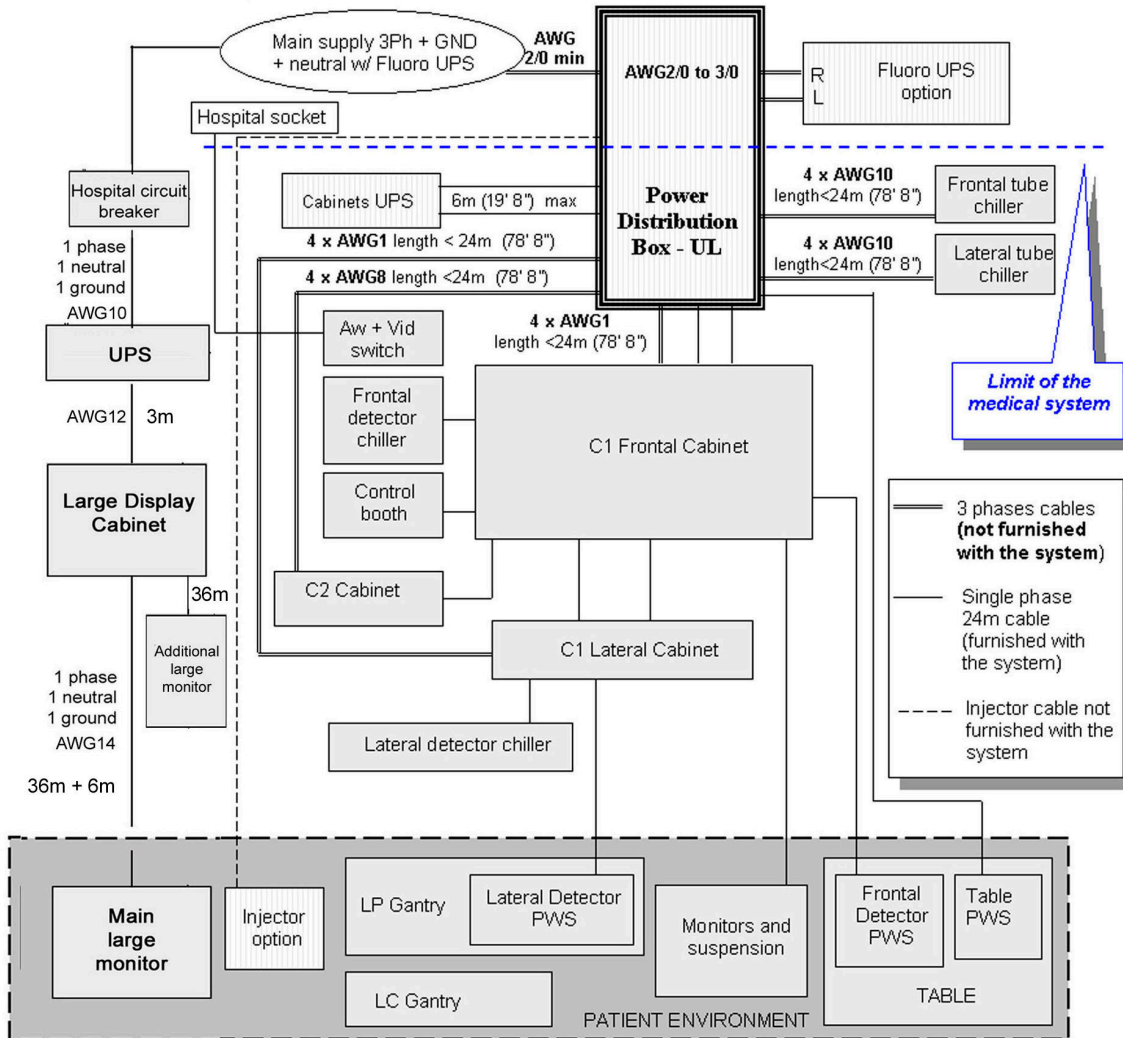

Figure 89 Power distribution - UL



Cable	CE UPS configuration		UL UPS configuration			Max length
	Recommended (1)	Type	Max gauge	Recommended (1)	Type	
R rectifier	5 x 10 mm ²	3ph+N+PE	AWG3	AWG6	3ph+N+PE	24 m (78ft 8in)
L out /load	5 x 10 mm ²	3ph+N+PE	AWG3	AWG6	3ph+N+PE	24 m (78ft 8in)

(1) Size and type may be adapted locally per local regulation.

NOTE

Electrical contractor is responsible for providing the power cables from Hospital mains to Large Display UPS and the ground cable from Hospital mains to Large Display Cabinet as per local regulations.

5.1.3 Emergency Failure

During an examination, any operator can encounter two main cases of failures.

5.1.3.1 Main power supply cut

In this case, refer to [5.4.1 Physical Runs on page 158](#).

5.1.3.1.1 Partial UPS Fluoro (option)

A Fluoro UPS (20 kVA) has been designed for systems with 21 & 31 cm detector. This partial UPS lets the customer complete an exam in fluoro mode in case of a power failure. The autonomy provided by this UPS is 5 minutes of fluoro every 24 hours.



DO NOT CONNECT THE UPS BATTERIES PRIOR THE COMMISSIONING OF THE UPS (INITIAL POWER UP).



NOTICE

General safety instructions

- Move the UPS in an upright position in its original package to the final destination room. To lift the cabinets, use a forklift or lifting belts with spreader bars.
- Check for sufficient floor and elevator loading capacity.
- Check the integrity of the UPS equipment carefully.
- If you notice visible damage, do not install or start the UPS. Contact the nearest Service Center immediately. **WARNING! RISK OF ELECTRICAL SHOCK:** Do not remove covers; there are no user serviceable parts inside.
- All installation, maintenance and service work should be performed by qualified service personnel. The UPS contains its own energy source (battery).
- The field-wiring terminals may be electrically live, even when the UPS is disconnected from the utility.
- Dangerous voltages may be present during battery operation. The battery must be disconnected during maintenance or service work.
- This UPS contains potentially hazardous voltages.
- Be aware that the inverter can restart automatically after the utility voltage is restored.



NOTICE

Installation safety instructions:

- Contractor responsibility:
 - Electrical contractor is responsible for providing and connecting the cables and configuring the PDB in by-pass mode.
 - GEHC is responsible for powering on the system with the UPS in by-pass mode.
 - GEDE is responsible for UPS commissioning.
- After removing the sidewalls of the UPS, make sure that all earth connections when reassembling, are correctly reattached.
- This UPS is intended for use in a controlled indoor environment free of conductive contaminants and protected against animals intrusion.
- HIGH GROUND LEAKAGE CURRENT: Ground connection is essential before connecting to AC input! For Europe only, if a differential breaker is placed on the hospital main supply, upstream the PDB, the differential shall be set to 300 mA.
- Switching OFF the unit does not isolate the UPS from the utility.
- Do not install the UPS in an excessively humid environment or near water.
- Avoid spilling liquids on or dropping any foreign object into the UPS.
- The unit must be placed in a sufficiently ventilated area; the ambient temperature should not exceed 104°F (40°C).
- Optimal battery life time is obtained if the ambient temperature does not exceed 77°F (25°C).
- It is important that air can move freely around and through the unit. Do not block the air vents.
- Avoid locations in direct sunlight or near heat sources.
- Check local regulations for UPS installation.



NOTICE

Storage safety instructions:

- Store the UPS in a dry location; storage temperature must be within -13°F (-25°C) to 131°F (55°C).
- If the unit is stored for a period exceeding 3 months, the battery must be recharged periodically (time depending on storage temperature).

**NOTICE**

Battery safety instructions:

- The battery-voltage is dangerous for person's safety.
- Never dispose of battery in a fire: They may explode.
- Do not open or mutilate battery: Their contents (electrolyte) may be extremely toxic. If exposed to electrolyte, wash immediately with plenty of water.
- Avoid charging in a sealed container.

5.1.3.1.2 Full UPS Record (compatibility)

An UPS sized for a minimum of 160 kVA is required to supply the system in record mode. Such an UPS would provide to the customer about 10 minutes of autonomy.

The UPS output shall follow the same output specifications as shown in **Optional Isolation transformer specifications** in [5.1.1 Electrical Requirements on page 135](#).

Contact your local GE Healthcare representative for more information and/or public power distribution analysis.

5.1.3.2 System failure

In the event of a system failure with a patient on table during an examination, the operator can utilize a Surgical Imaging mobile unit to finish the examination.

In this case a wall outlet single phase + ground is required to feed the mobile. It also requires a free space around the patient table to proceed with the mobile instead of Frontal Positioner. The table has to rotate to 90°. The minimum room width of 4400 mm (14.5 in) may not be sufficient for this scenario.

5.1.4 Power Distribution System

**NOTICE**

It is recommended to separate power supply cables from the other cables.

5.1.4.1 Power Distribution Box - CE

Figure 90 PDB CE - 50 Hz



Figure 91 PDB Schematic CE - 1/2

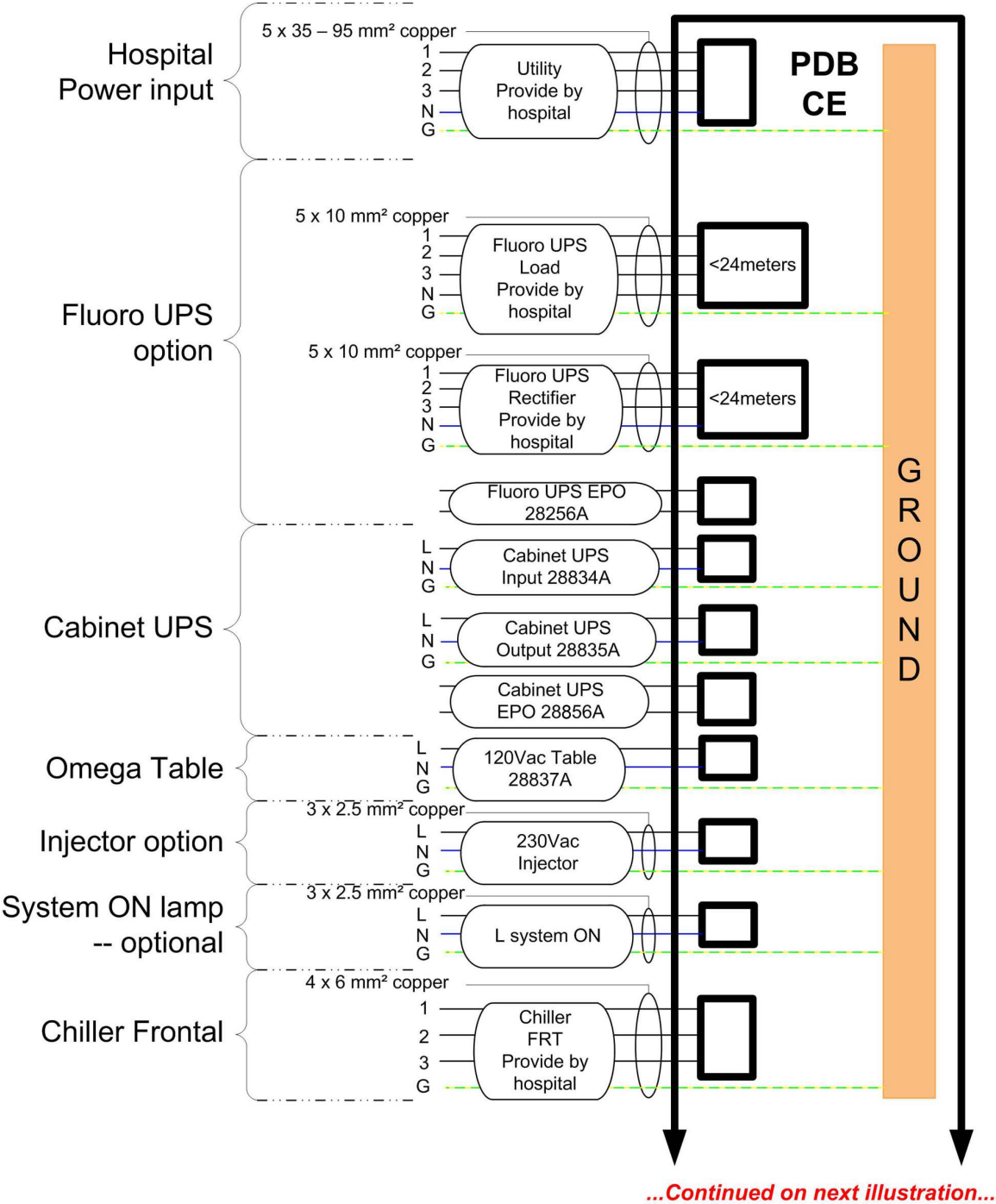
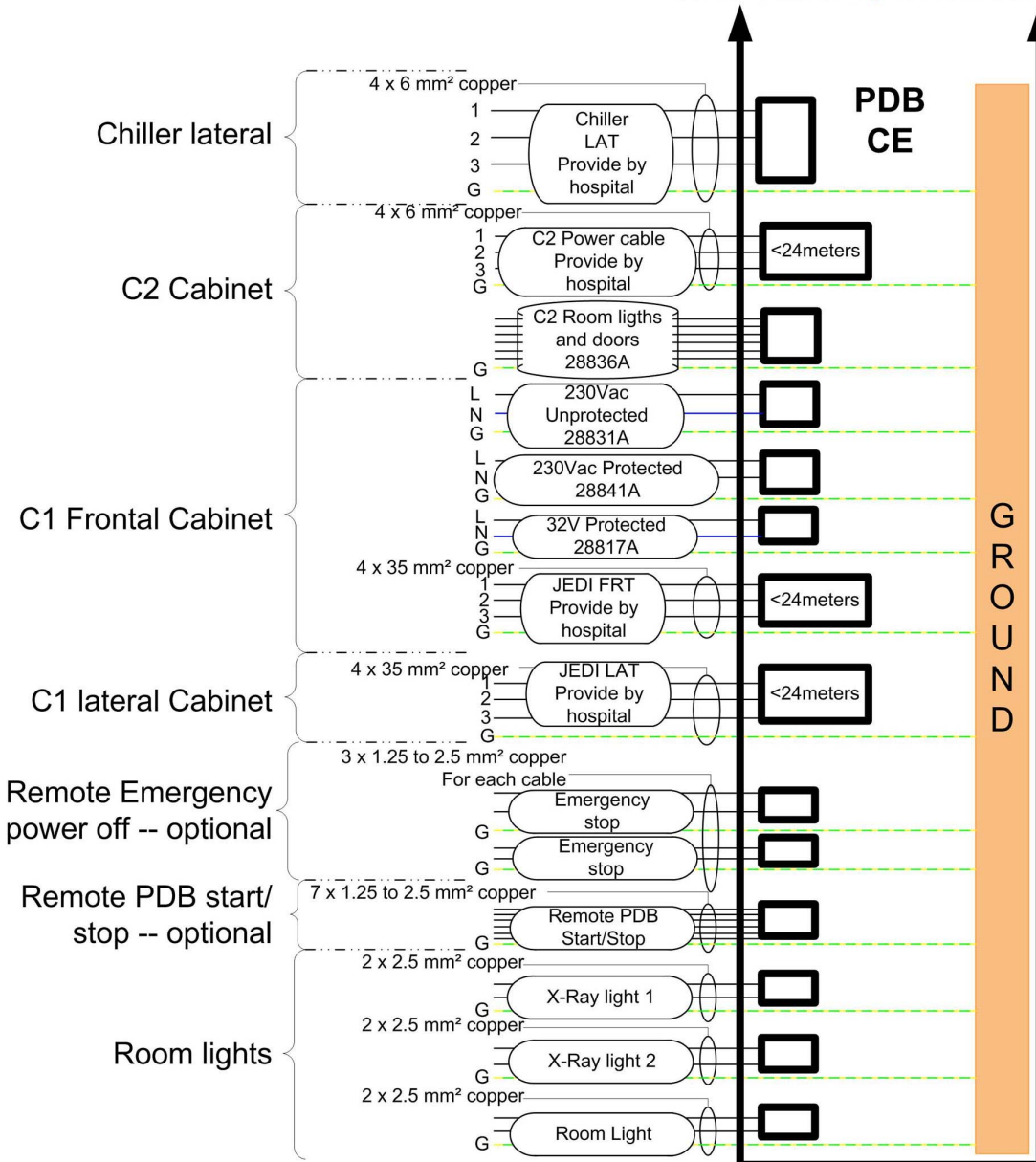

Figure 92 PDB Schematic CE - 2/2

...Continued from previous illustration...



5.1.4.2 Power Distribution Box - UL

Figure 93 PDB UL - 60 Hz (US only)

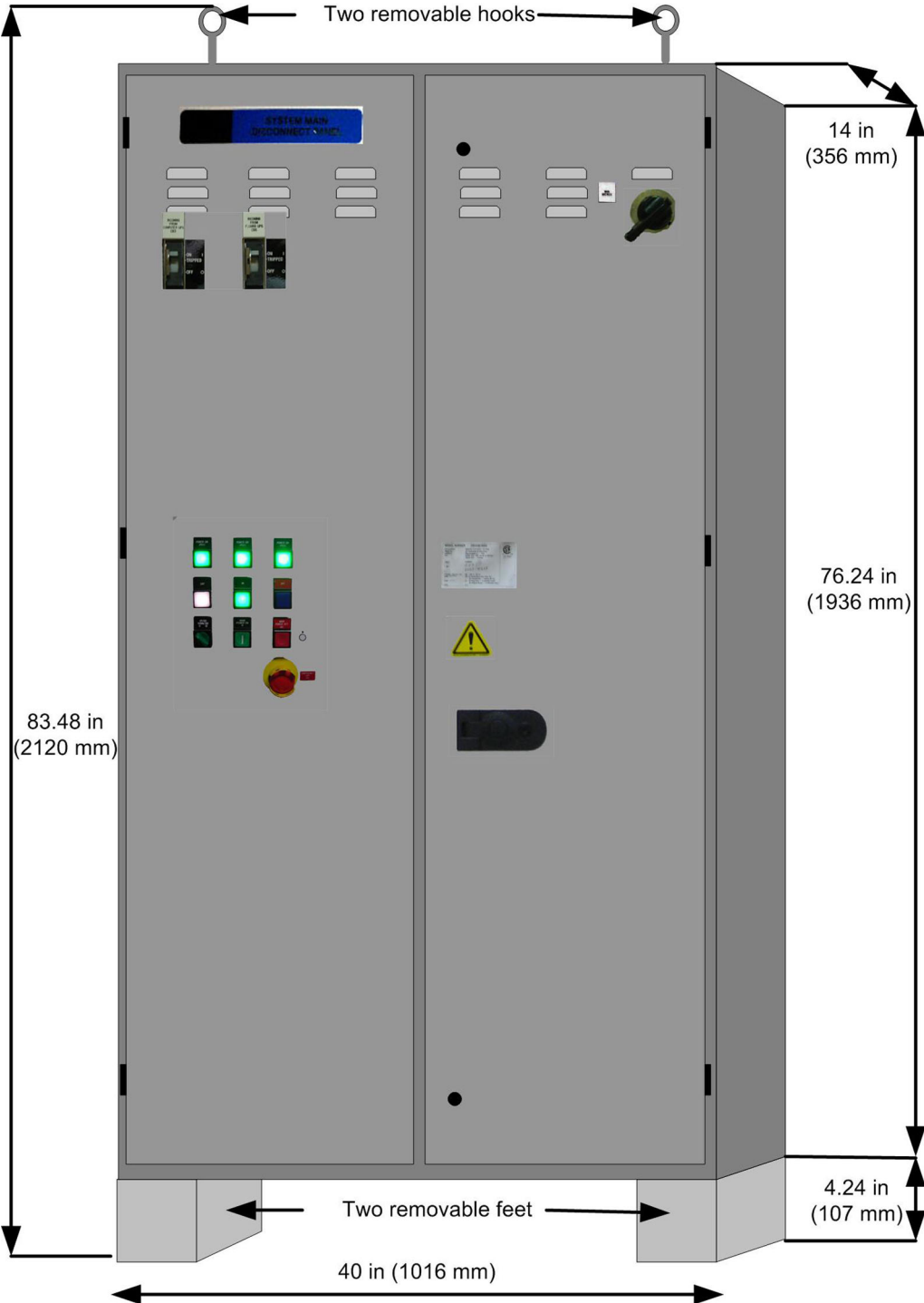

Figure 94 PDB Schematic UL - 1/2

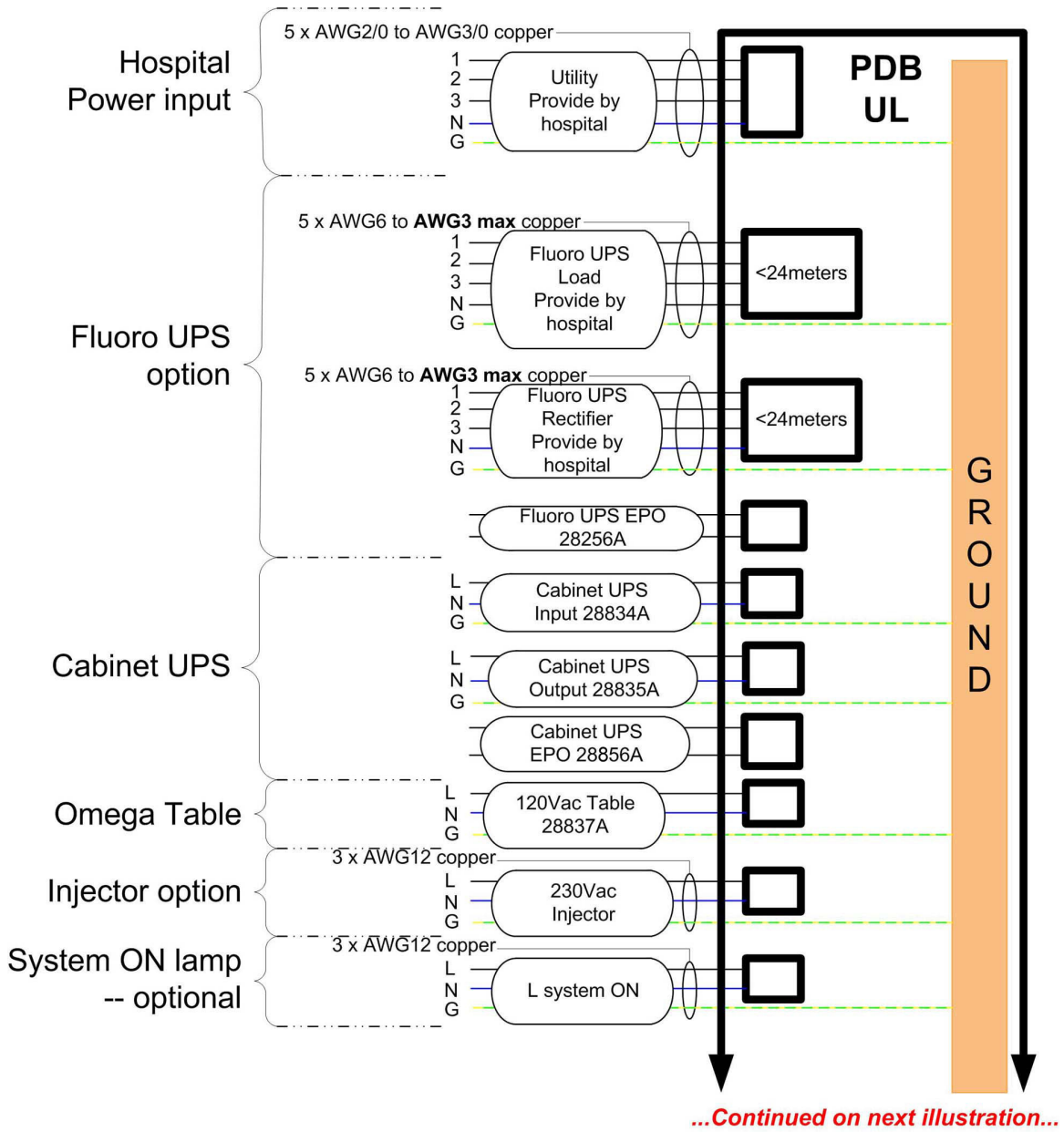
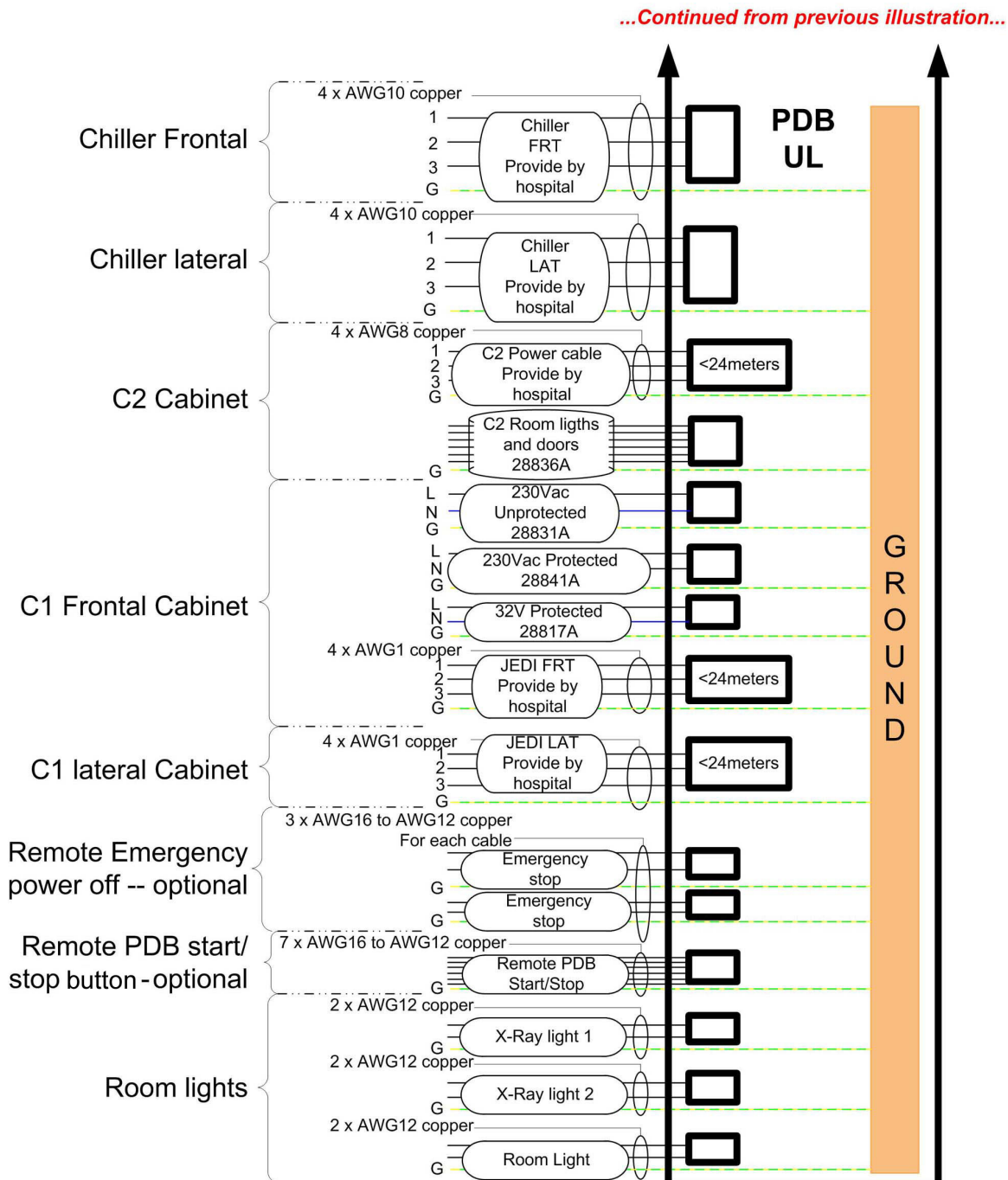

Figure 95 PDB Schematic UL - 2/2



5.2 Grounding

5.2.1 Grounding

A vascular lab is a critical care area and requires a special grounding system for patient safety. An equipotential grounding system is recommended for meeting patient safety requirements.

Reference: For general system grounding requirements and information on establishing an equipotential grounding system, refer to:

- Grounding Continuity – Job card in the Installation manual



NOTICE

All shielded cables shall have a connection to ground at each extremity without regard to the grounding to the scheme below.



NOTICE

Metallic covers on cable connectors shall be tested to ground.

Figure 96 Grounding distribution

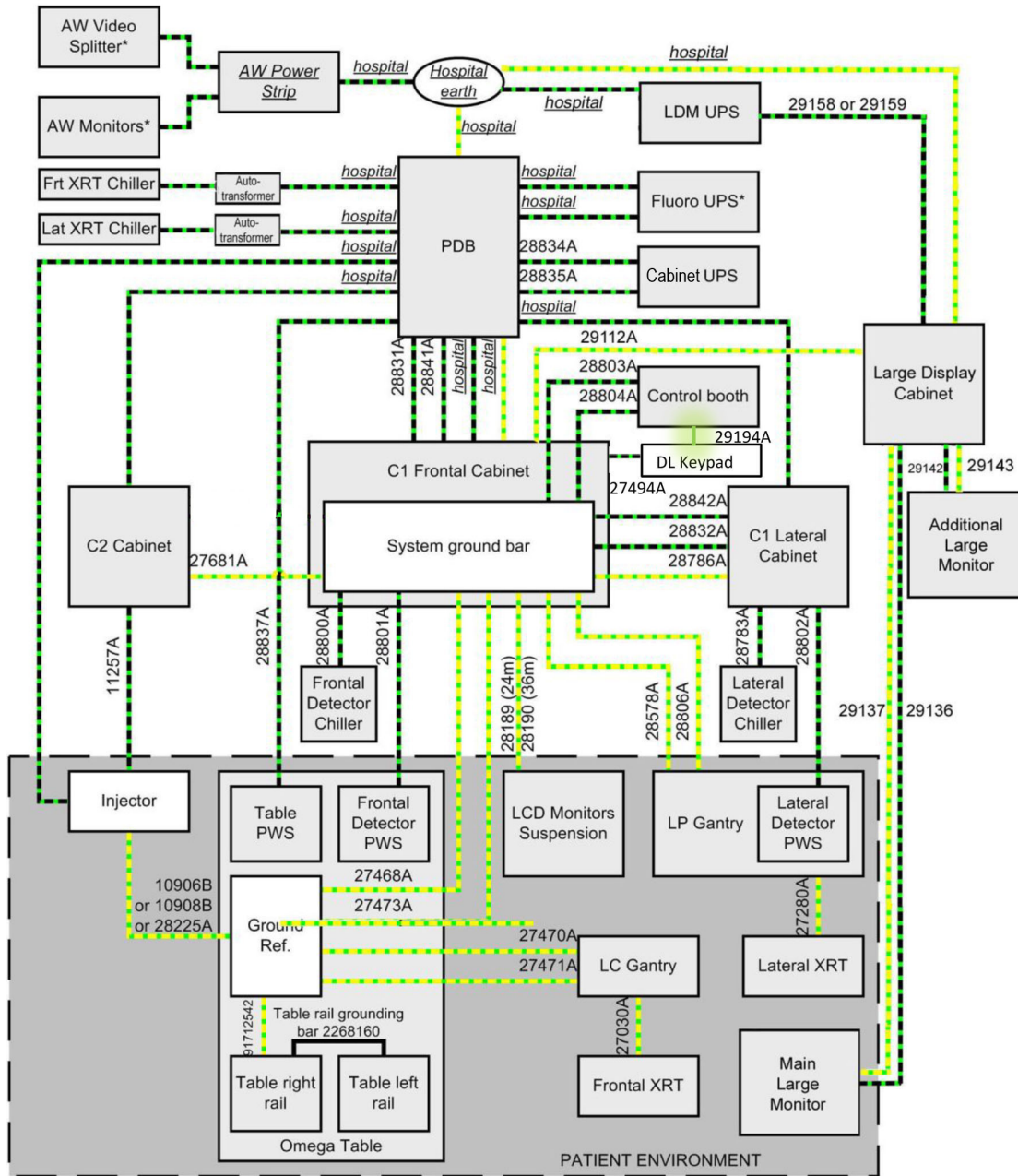

* Option
italic and underline Provided by hospital
— Dedicated ground cable
— A/C power & ground group cable

Table 34

CABLE	FROM	TO	WIRE GAUGE	
<i>hospital</i>	AW Power Strip	Ground	-	
<i>hospital</i>	PDB	C1 Frontal Cabinet	35 mm ²	AWG1

continued				
CABLE	FROM	TO	WIRE GAUGE	
<i>hospital</i>	PDB	C1 Frontal Cabinet	35 mm ²	AWG2
<i>hospital</i>	PDB	C1 Lateral Cabinet	35 mm ²	AWG1
<i>hospital</i>	PDB	C2 Cabinet	6 mm ²	AWG8
<i>hospital</i>	PDB	Fluoro UPS	10 mm ²	AWG6
<i>hospital</i>	PDB	Fluoro UPS	10 mm ²	AWG6
<i>hospital</i>	PDB	Frontal XRT Chiller	6 mm ²	AWG10
<i>hospital</i>	PDB	Ground	35 mm ² mini	AWG2/0 mini
<i>hospital</i>	PDB	Injector	AWG10	
<i>hospital</i>	PDB	Lateral XRT Chiller	6 mm ²	AWG10
<i>hospital</i>	Hospital mains	LDM UPS	AWG12	
<i>hospital</i>	Hospital mains	LDM cabinet	AWG12	

5.2.2 Power and Grounding Requirements

- A breaker with cut-out capability shall be installed by the customer (or his contractor) next to the PDB. It is needed for the LOTO procedure in front of the PDB.
- The main facility ground conductor to the PDB shall be copper wire and the minimum size as required by the local coding regulations, such as the NEC. For countries, which are not covered by local requirement (like NEC), the ground wire to earth should be at minimum of AWG 2/0 (150 A breaker) UL or 35mm² (80 A breaker) CE, or same size (100%) as feeder wires, whichever is larger.
- Power cables must not be used to supply other systems
- Cables shall be in conformity with local regulation (UL, CSA, IEC, CCC).

Table 35

Max Line Impedance for feeder line between Generator cabinet and Hospital						
V	380	400	415	440	460	480
Ohms	0.09	0.096	0.101	0.108	0.114	0.12

NOTE

These 3 phases cables are not furnished by GE Healthcare. Provided by installer.

- These cables must be kept separated as much as possible from room system cables.
- The shield of any shielded cable coming from the distribution cannot replace the ground wire.

Reference: For specific Vascular system grounding maps and connection details, refer to the MisMap and mis chart listed in 5.3.1 MIS (Master Interconnect System) on page 154.

Large Display option requirements:

The Large Display option must be powered through a wall circuit breaker or equivalent device with LOTO capability. This circuit breaker must have a 30 amps current rating. Procurement, delivery and installation of this device is customer’s responsibility. The customer shall provide the power supply cables from this circuit breaker to the LDM UPS, and the ground cable from the main power to the LDM cabinet.

Table 36 System FEEDER from hospital

UL		Power supply voltage 480 V								
		Panel (PDB) to C1 run in m (ft)								
		8 (26)	16 (52)	24 (79)						
Feeder run length:	10 m (30 ft)	2/0	2/0	2/0	 <p>WARNING</p> <p>RECOMMENDED FEEDER CABLE GAUGE : FOR PHASES, NEUTRAL & GROUND PDB INPUT TERMINALS ACCEPT 2/0 AND 3/0 AWG. BIGGER CABLES NEEDS A SIZE REDUCTION BEFORE PDB ENTRY.</p>					
	20 m (70 ft)	2/0	2/0	2/0						
	30 m (100 ft)	2/0	2/0	3/0						
	40 m (130 ft)	2/0	2/0	250						
	50 m (160 ft)	2/0	3/0	300						
	60 m (200 ft)	3/0	4/0	400						
	80 m (260 ft)	4/0	350	600						
	100 m (330 ft)	300	500	see Note						
	120 m (390 ft)	400	600	see Note						
CE		Power supply voltage								
		380 V			400 V			415 V		
		Panel (PDB) to C1 cabinet run								
		8 m	16 m	24 m	8 m	16 m	24 m	8 m	16 m	24 m
Feeder run length:	10 m	35	35	35	35	35	35	35	35	35
	20 m	35	35	70	35	35	50	35	35	50
	30 m	50	70	95	35	50	70	35	50	70
	40 m	50	70	120	50	70	95	50	70	95
	50 m	70	95	185	70	95	120	70	95	120

60 m	95	120	240	70	95	185	70	95	150
80 m	120	185	300	95	150	300	95	120	240
100 m	185	240	see note	150	240	see note	120	185	see note
120 m	240	300	see note	185	300	see note	185	240	see note



NOTICE

Recommended feeder cable section in mm² : for PHASES, NEUTRAL & GROUND PDB input terminals accept 35² to 95². Bigger cables needs a size reduction before PDB entry.

NOTE

Increasing transformer power will decrease its voltage loss and feeder cables section. To be calculated site by site.

5.3 Interconnections

5.3.1 MIS (Master Interconnect System)

Innova system interconnect cables are described in MIS (Master Interconnect System) documents. These documents specify all interconnections between components within the system.

Reference: For specific Vascular system interconnect maps and connection details, refer to the following:

- *Innova™ IGS 620, Innova™ IGS 630 MIS Maps*
- *Innova™ IGS 620, Innova™ IGS 630 MIS Charts.*

General Guidelines

Innova System introduces a new system interconnect with a star distribution for all cables from the technical area. Cable group 1 for Exam room and cable group 2 for Control room. The cable group shall be put in place during the same action. The cables are routed in the same duct.

The HV cables could be pulled separately.

5.3.2 Cable Channeling

5.3.2.1 General

High voltage and power cables must be separated from other cables. Use a separate trough in the duct system, or use a separate conduit. Minimize cable length between the line disconnect and the System Cabinet power unit to reduce voltage regulation problems and wiring costs.

For information about the cables supplied with your system, please refer to [5.4.1 Physical Runs on page 158](#).

Raceways or cables trays containing electric conductors shall not contain any pipe, tube or equal for steam, water, air, gas, drainage or any service other than electrical

5.3.2.2 Conduit

Separate conduits must be used for power and signal wires. These wires must be kept separated from each other.

Using conduit imposes some important considerations when used with this system. Of primary concern, the majority of cables used are pre-terminated. Pre-termination greatly simplifies interconnection but makes cable-pulling difficult because of the added dimensions of the connectors.

Conduit must be large enough to pass the cable and connector through with all other cables already in the conduit. Also, the size of conduit chosen must allow for future growth. There is the possibility of additional cables being added later as the system is developed and options are added.

The use of conduit is recommended for cables running overhead between rooms, especially when a diagonal run provides the shortest cable path

5.3.2.3 Electrical Ducts

It's important that electrical ducts have separate compartments for power and signal wires. These wires must be kept separated from each other for proper system operation.

Electrical ducts have advantages, when used with a single room or two adjacent rooms. Electrical ducts combine cabling in a neat and functional appearance, with accessibility and room for expansion.

NOTE

Medrad AVANTA and Mac-lab cables exit behind the table in the patient room.

For Fast Link cable (C1 cabinet - AW station), the static operation bending radius must be at least 4 times the outer cable diameter.

It is the responsibility of the site planner to provide the appropriate solution to the table exit (e.g gas box, Clab II, Tram module, connection interface box)

NOTE

Specific Recommendations for installation with GE ECG Device such as MacLab, CardioLab or ComboLab:

- TRAM RAC in Exam Room with cable 2016134-106 routed back to Control Room where the other modules & PC are installed.
- If no GE Maclab cable 2016134-106 installed between the TRAM (Exam Room) and the Control Room, need to route it so that installation/connection of Physio module can be made in Control Room.

NOTE

MEDRAD Avanta Table mount: A 76.2 mm (3 in) and max 25 m (984 in) length conduit between technical room and patient room shall be prepared below the floor for the three injector cables. It is recommended to use the MEDRAD Avanta floor mounting bracket to cover the duct hole in the patient room if there is no gases box.

Floor mount installation can be accomplished one of two ways:

- Connectors mounted in trough under mounting bracket (Figure 1)
- Connectors mounted above mounting bracket (Figure 2)

Figure 97 MEDRAD Avanta floor mounting methods

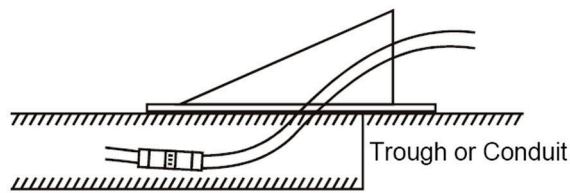

Figure 1

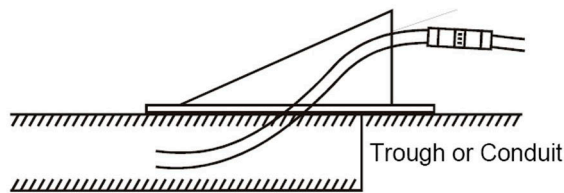

Figure 2

For further MEDRAD Avanta floor mounting, see the Installation guide *MEDRAD Avanta Floor Mounting Bracket*.

5.4 System Cable Information

5.4.1 Physical Runs

5.4.1.1 System Core Matrix



NOTICE

All lengths of cable are:

- in useable meter when you look at group level, or
- in meters (connector to connector) when you look at the cable level.

Suspension are always pre-cabled with 36 meter cables of connector to connector Monitor options includes their 24 meters length for cabling

In case 24 m required, they have to be added in the order and replaced on site.

For a description of how to use the following 5 cable group schematics, see below:

Figure 99 Description of cable group diagrams

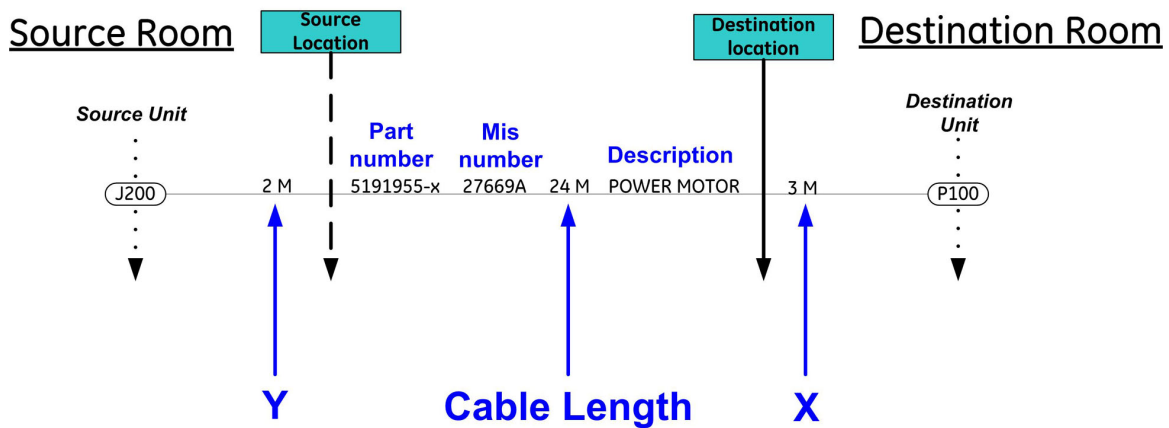

Cable length data is as follows:

- **Cable Length** = the total cable length, connector to connector (example above is 24 meters).
- **X + Y** = used length for connection within system (example above is 5 meters).
- **Cable Length - (X + Y)** = available length for conduit run (example above is 19 meters).

Figure 100 CABLE GROUP 1 – FROM TECHNICAL AREA TO EXAM AREA

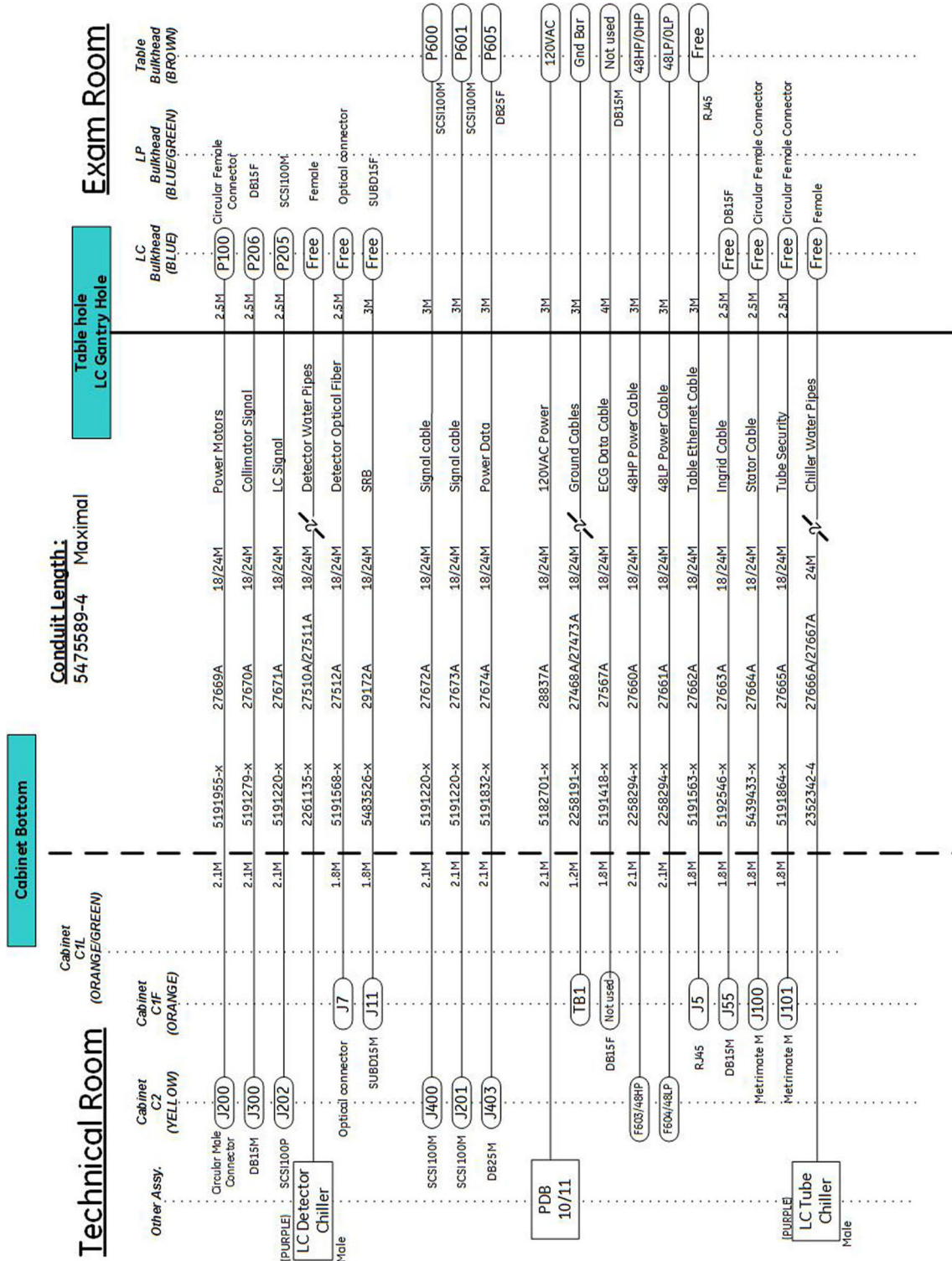

Figure 101 CABLE GROUP 2- FROM TECHNICAL AREA TO CONTROL AREA

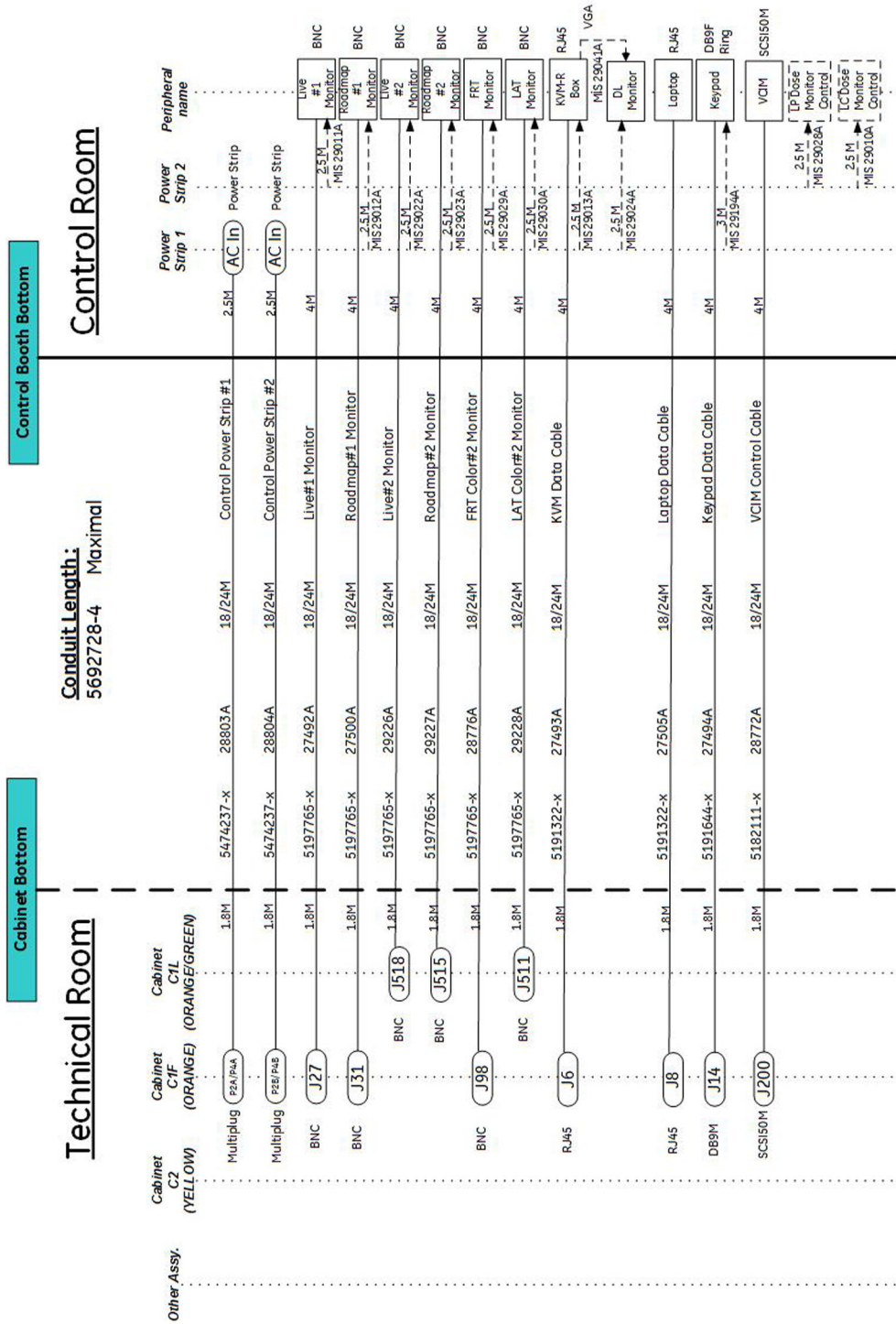

Figure 102 Cable Group - Fast Link Option

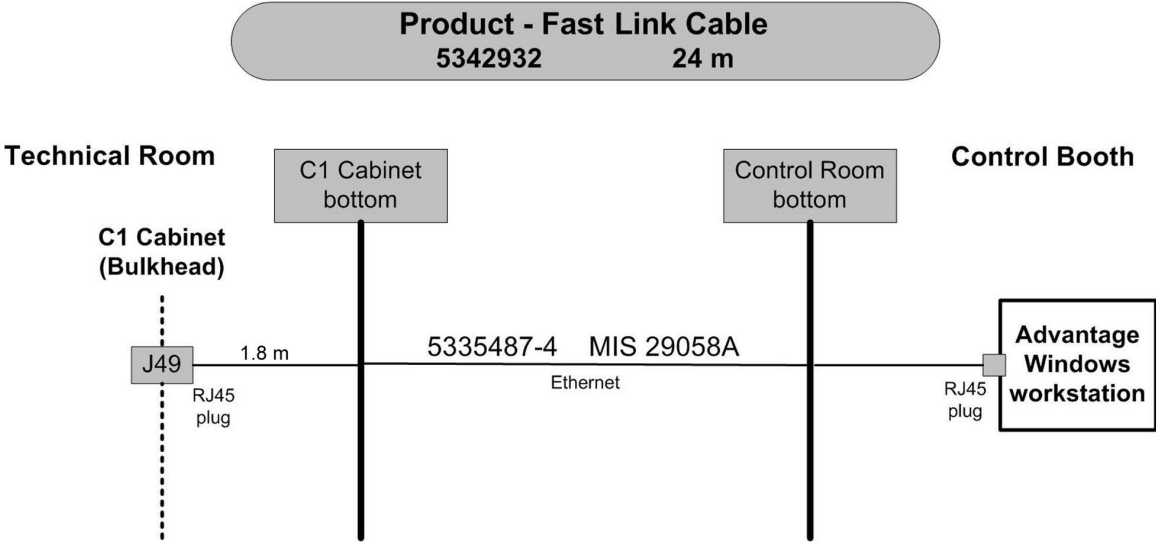

Figure 103 CABLE GROUP 3 - FROM TECHNICAL AREA TO TECHNICAL AREA

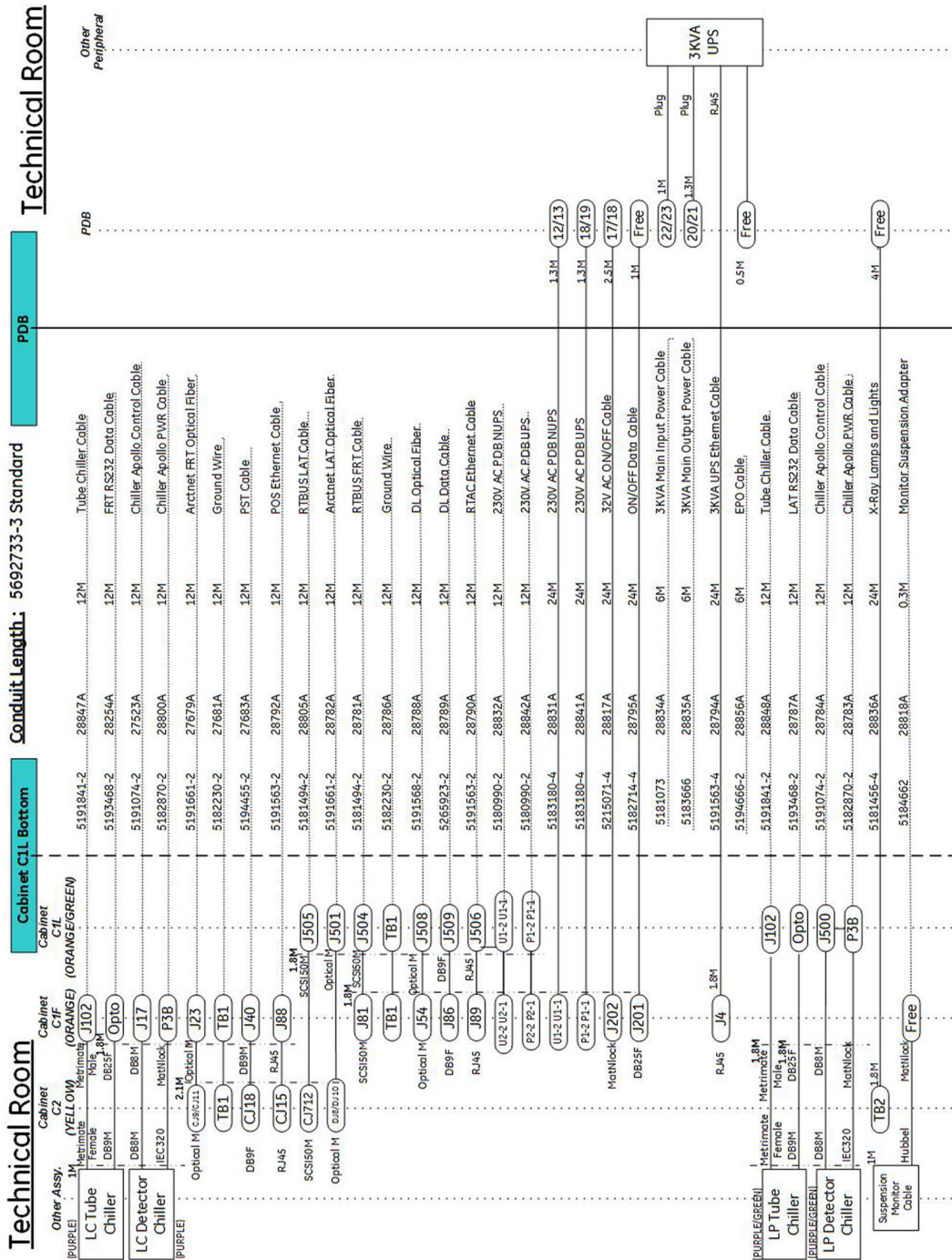

Figure 104 CABLE GROUP 4 - FROM TECHNICAL AREA TO EXAM AREA

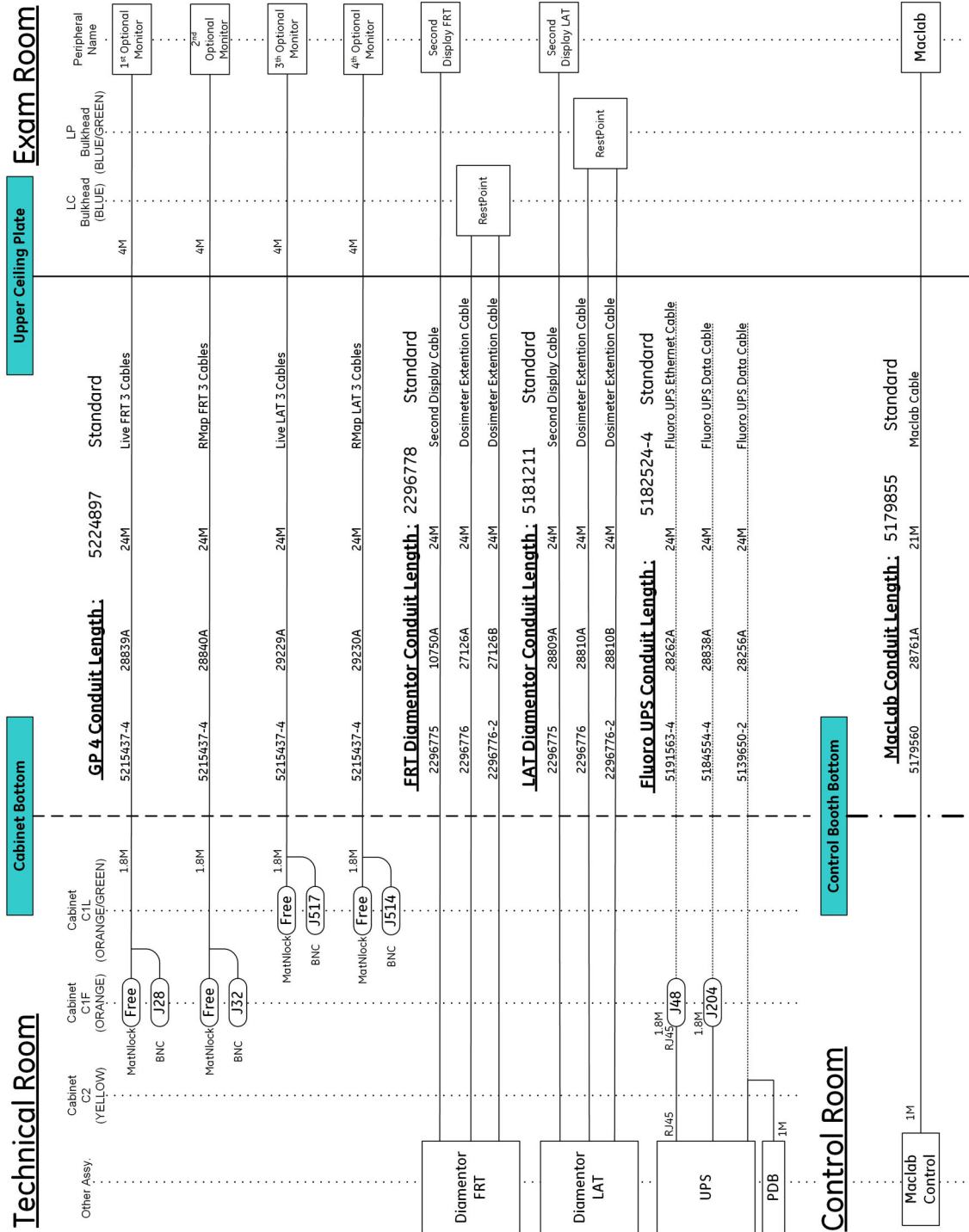
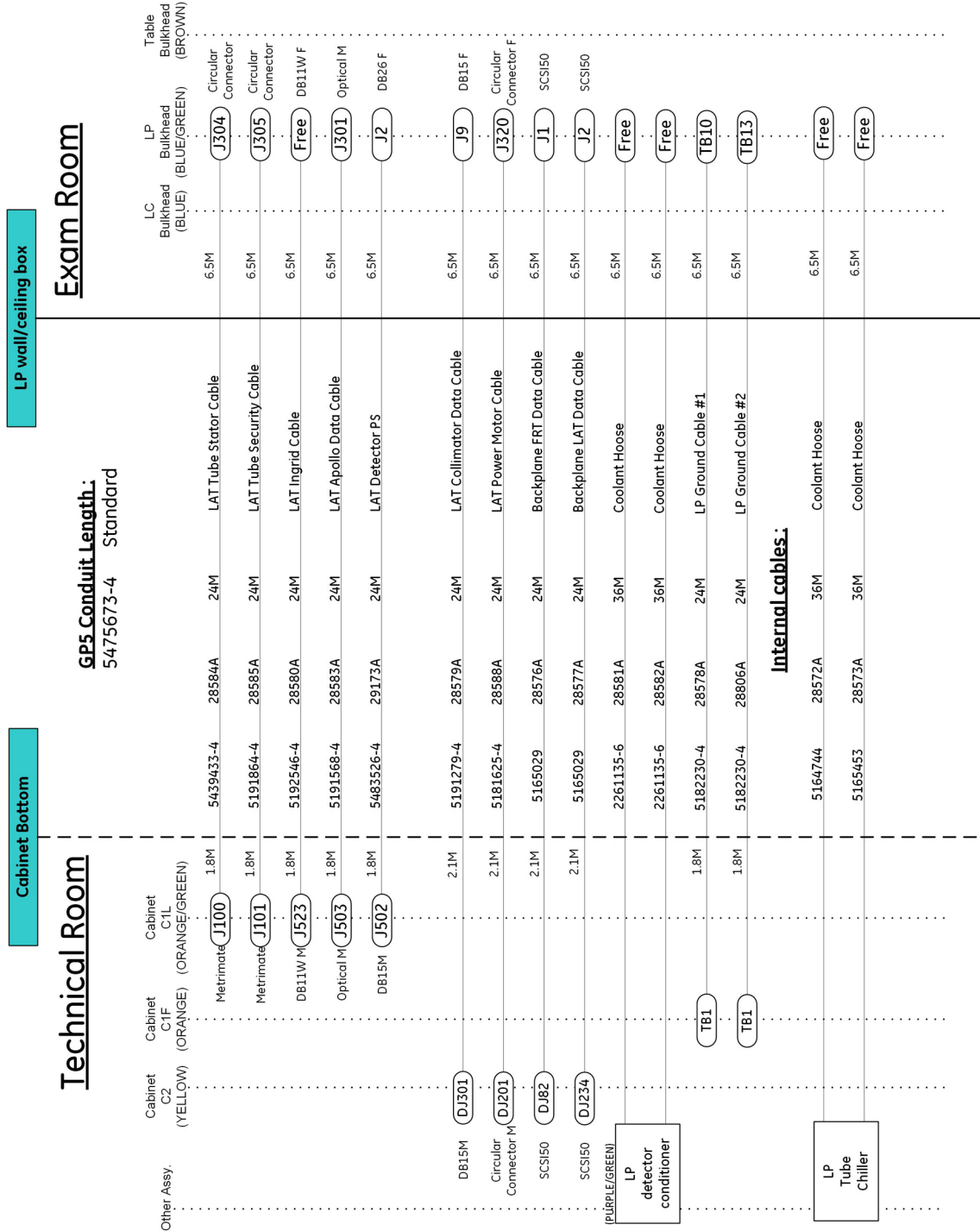

Figure 105 CABLE GROUP 5 - FROM TECHNICAL AREA TO EXAM AREA



5.4.1.2 Physical Run - System Core Detail

Table 37

MIS number	Cable Assembly	UL Style	Voltage rating (V)	Max Voltage carried (V)	Cable diameter (mm)	Connector type	Bigger Plug size (mm)
Group n°1 (From Technical Room to Exam Room)							
27468A	2258191						
27473A	2258191						
27510A	2261135	WATER HOSE					
27511A	2261135	WATER HOSE					
27512A	5191568	OPTICAL FIBER					
27567A	5191418						
27660A	2258294						
27661A	2258294						
27662A	5191563		30		7	AMP 8 pin RJ45	
27663A	5192546	2789	600		13.8	DB 11 pin	34.4
27664A	5439433						
27665A	5191864						
27666A	2352342	WATER HOSE					
27667A	2352342	WATER HOSE					
27669A	5191955						
27670A	5191279						
27671A	5191220	2789	30		10.9	Amplimite 100 pin	84.6
27672A	5191220	2789	30		10.9	Amplimite 100 pin	84.6
27673A	5191220	2789	30		10.9	Amplimite 100 pin	84.6
27674A	5191832						
28837A	5182701						
29172A	5483526	2464	300		12.7		
Group n°2 (From Technical Room to Control Room)							
27492A	5197765						

continued							
MIS number	Cable Assembly	UL Style	Voltage rating (V)	Max Voltage carried (V)	Cable diameter (mm)	Connector type	Bigger Plug size (mm)
27493A	5191322	Category 5	150		5.5	RJ45	14.1
27494A	5191644						
27500A	5197765						
27505A	5191322	Category 5	150		5.5	RJ45	14.1
28772A	5182111						
28776A	5197765						
28803A	5474237						
28804A	5474237						
29010A	5305995						
29011A	5305995						
29012A	5305995						
29013A	5305997						
29022A	5305995						
29023A	5305995						
29024A	5305995		1				
29028A	5305995						
29029A	5305995						
29030A	5305995						
29041A	5323606						
29194A	5543436	1015	600		4	IEC Connector - ring terminal	
29226A	5197765						
29227A	5197765						
29228A	5197765						
Group n°3 (From Technical Room to Technical Room)							
27523A	5191074						
27679A	5191661						

continued							
MIS number	Cable Assembly	UL Style	Voltage rating (V)	Max Voltage carried (V)	Cable diameter (mm)	Connector type	Bigger Plug size (mm)
27681A	5182230						
27683A	5194455						
28254A	5193468						
28781A	5181494						
28782A	5191661	OPTICAL FIBER					
28783A	5182870						
28784A	5191074						
28786A	5182230						
28787A	5193468						
28788A	5191568	OPTICAL FIBER					
28789A	5265923						
28790A	5191563						
28792A	5191563						
28795A	5182714						
28799A	5182561						
28800A	5182870						
28805A	5181494						
28817A	5215071						
28818A	5184662						
28831A	5183180						
28832A	5180990						
28834A	5766674						
28835A	5183666						
28836A	5181456						
28841A	5183180						
28842A	5180990						
28847A	5191841						

continued							
MIS number	Cable Assembly	UL Style	Voltage rating (V)	Max Voltage carried (V)	Cable diameter (mm)	Connector type	Bigger Plug size (mm)
28848A	5191841						
28856A	5194666						
29285A	5760830						
Group n°5 (From Technical Room to Exam Room)							
28576A	5165029						
28577A	5165029						
28578A	5182230						
28579A	5191279						
28580A	5192546						
28581A	2261135						
28582A	2261135						
28583A	5191568						
28584A	5439433						
28585A	5191864						
28588A	5181625						
28806A	5182230						
29173A	5483526						
Fast Link cable group							
29058A	5335487				5.9	RJ45	14.1
Group LDM for Biplane							
29115A	5305381						
29116A	5305381						
29117A	5305381						
29164A	5431888						
System Cables for LDM and UPS							
27678A	5409695						
29107A	5305381						

continued							
MIS number	Cable Assembly	UL Style	Voltage rating (V)	Max Voltage carried (V)	Cable diameter (mm)	Connector type	Bigger Plug size (mm)
29108A	5305381						
29109A	5305381						
29110A	5191563						
29111A	5414103						
29112A	5419212						
29158A	5427518						
29159A	5427519						
29163A	5431888						
Dispatch Cable							
27694	5487798						
28641	5341048						
29176	5487504						
Cable select live add Monitor GP4.6							
29229A	5215437						
Cable select Roadmap add Monitor GP4.7							
29230A	5215437						
Innova Diamentor Cable Set							
27126A	2296776						
27126B	2296776						
Innova Diamentor Lateral Cable Set							
28809A	2296775						
28810A	2296776						
28810B	2296776						
Innova Fluoro UPS Cable Set Standard Length							
28256A	5139650						
28262A	5191563						
28838A	5184554						

continued							
MIS number	Cable Assembly	UL Style	Voltage rating (V)	Max Voltage carried (V)	Cable diameter (mm)	Connector type	Bigger Plug size (mm)
Mac LAB Cable Standard Length							
28761A	5179560						

5.5 X-Ray ON Lamp Distribution

The fitter shall install an X-Ray On lamp in the Exam room, and in the control room if necessary, outside the patient area, so that they are connected to the equipment through connection terminals.

NOTE

Innova systems with 21 & 31 cm detector provides 24 VAC for driving X-Ray ON line.

Hospital or contractor to provide 1.5 mm² (AWG 14) wires to connect to the system.

X-Ray ON lamp is active during X-Ray exposures.



THE X-RAY ON LAMP MUST BE INSTALLED IN THE EXAM ROOM TO CONFORM TO INTERVENTIONAL STANDARD IEC/EN 60601-2-43.

SIGNAL INDICATING THE X-RAY ON SHALL BE PERCEPTIBLE BY THE OPERATOR IN ALL THE LOCATIONS DEFINED FOR THE PERSONNEL WHO MAY RECEIVE SCATTERED RADIATION.

In the control room, an additional X-Ray on light must be installed if the console (VCIM) indicator cannot be perceived by all the persons in the control room.

Figure 106 X-Ray ON cabling between C2 cabinet and PDB

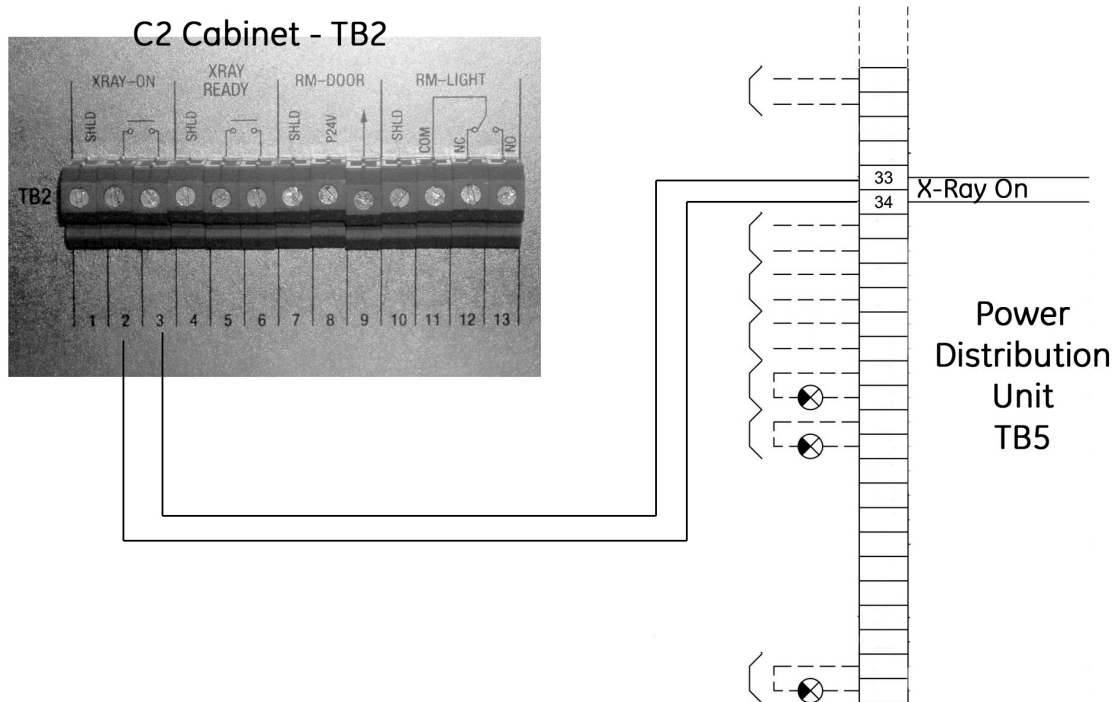

5.6 Ready For X-Ray Lamp

Innova systems with 21 & 31 cm detector provides contacts for driving a **Ready for X-Ray** lamp. These contacts are terminals 5 and 6 of TB2 bulkhead connector of the C2 cabinet.

Figure 107 X-Ray READY cabling between C2 cabinet and PDB

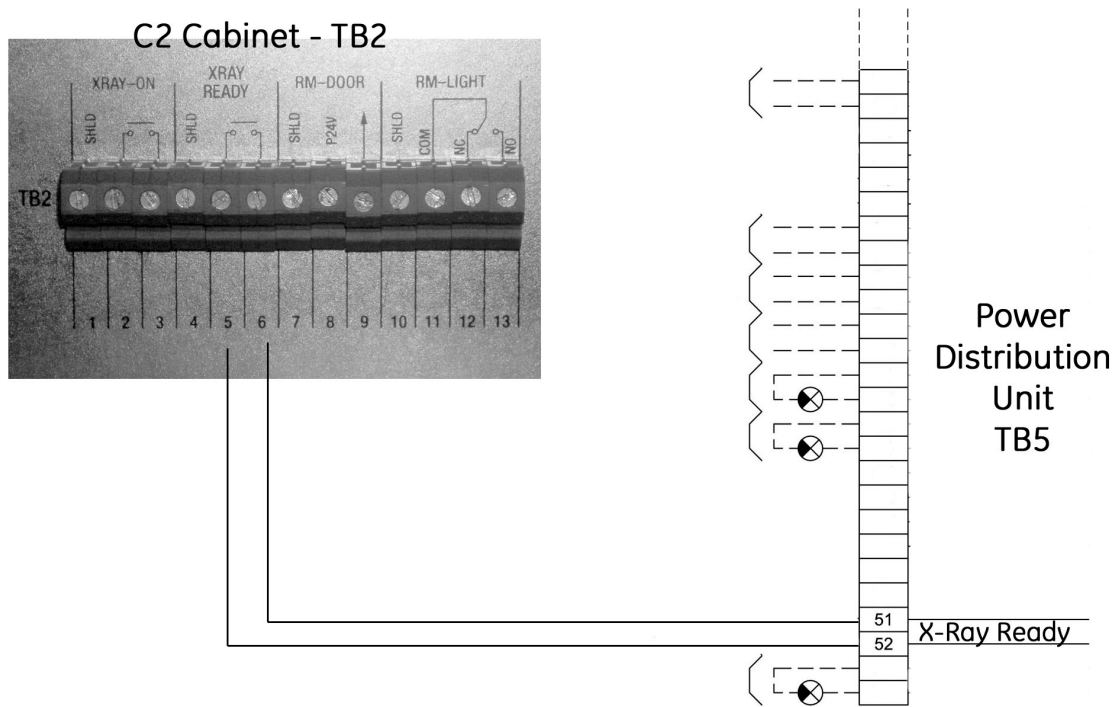

NOTE

Check local regulations if this indication is required.

If needed, the lamp needs to be provided by the hospital or their contractor.

5.7 Door Interlocks



IEC 60601-2-43 requires not to install door interlocks. It is the responsibility of the field service to check that this requirement is not in contradiction with local regulation. In case of conflict, follow local regulation. No other measures employed for radiation protection should cause the interruption of irradiation and any other disturbance of a procedure in progress.

Figure 108 C2 cabinet bulkhead RM DOOR connecting

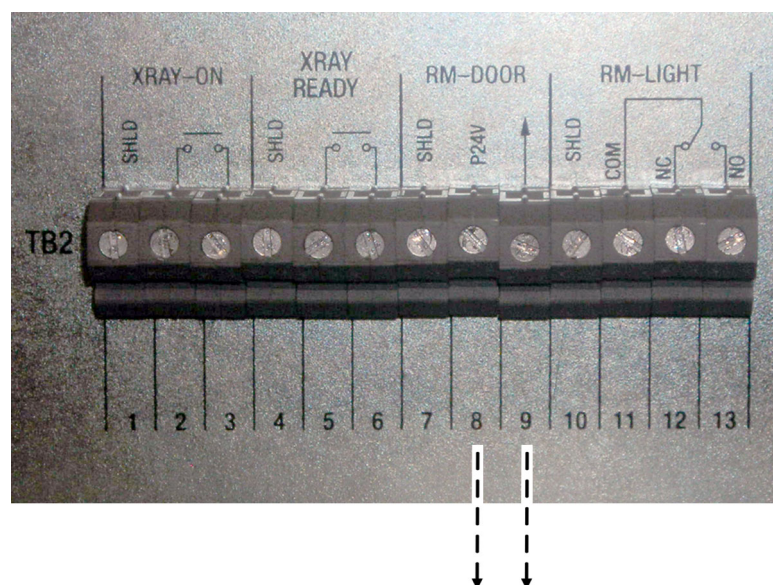

5.8 Room Speaker

The remote speaker provides the operator in the exam room, the indication of record exposure sequence (same level information as provided by the control room control panel).

The speaker must be installed in the exam room out of the patient vicinity to give easy access to the FE for maintenance operations and to medical staff to adjust the tone signal level and to be able to see the power LED indicator.

Figure 109

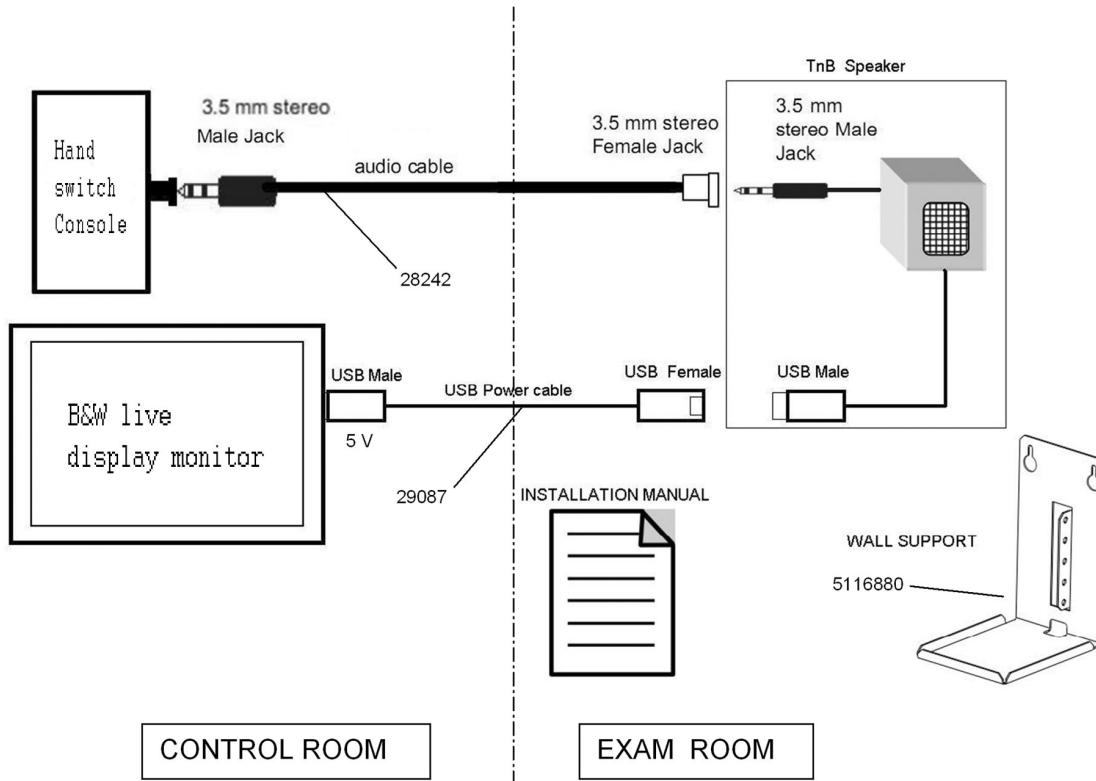

THE REMOTE SPEAKER KIT SHALL NOT BE INSTALLED IN THE PATIENT VICINITY.

Patient Vicinity Definition : see *Patient Environment Equipment* in [2.2.3 Room Layout Considerations](#) on [page 78](#)

5.9 MAC-LAB System EX

For location of MAC-LAB Acquisition Unit Floor mount kit 408431-001, refer to *Electrical Ducts* in [5.3.2 Cable Channeling](#) on [page 154](#).

For MAC-LAB System EX, refer to:

- Marquette document P/N 2000465-001 Preinstallation Guide

5.10 Advantage Windows

A power cord is supplied with Advantage Windows. It is connected to outlet fed by the main disconnect room device.

Verify that the ground between AW, AW splitter and monitors ground are equipotential (0.1 ohm equipotentiality between room ground point (busbar) and wall outlets).

**NOTICE**

To power the AW splitter, use the appropriate cable out of lot P/N 2385173.

5.11 Injectors

The injector is provided with an additional ground cable (P/N #2135737) to meet equipotentiality requirement at patient vicinity.

Injector emergency power off:

- if no emergency power off is required for the injector, the injector can be powered from a wall outlet socket.
- if emergency power off circuit must include the injector, ensure the power for the injector is via the PDB.

5.11.1 Remote Injector (rack mount)

A power cord is supplied with the injector.

110 VAC or 230 VAC are supplied from the main disconnect room device. The injector must be connected to this supply.

5.11.2 Pedestal Injector

A power cord is supplied with the injector.

In all cases (110 VAC or 230 VAC), it will be connected to a wall outlet near the operator location, fed by the main disconnect room device.

5.12 Lighting Specifications

5.12.1 Room Light Distribution

5.12.1.1 Requirements for lighting

Requirement for lighting concern the following, general, light-technique characteristics:

- Illuminator level.
- Lighting distribution.
- Preventing the operator from being dazzled by the light (by direct light sources or by reflection on bright objects).

The Illumination level must be compliant with established lighting technical rules and be as constant as possible.

Technical room, operating room and control room shall be provided with appropriate lighting in the maintenance area (maintenance area to be considered are service workplaces). It corresponds to service areas as defined for any of the product components.

The minimum required average luminance E_m shall be of 500Lx and minimum color rendering factor Ra of 80 as per IEC/EN 12464-1 (Light and lighting. Lighting of work places. Indoor work places: Illumination requirements for indoor workplaces corresponding to assembly of medium size electrical components, e.g. control panel) for the electrical industry).

5.12.1.2 Lighting Relay

Innova systems with 21 & 31 cm detector has the ability to control an external relay that applies power to the room light (dry contacts).

The relay is to be provided by the hospital or contractor.

The wire size to connect to the C2 cabinet is 1.5 mm² (AWG 14).

Relay rating is max 600 VAC

Figure 110 ROOM LIGHT cabling between C2 cabinet and PDB

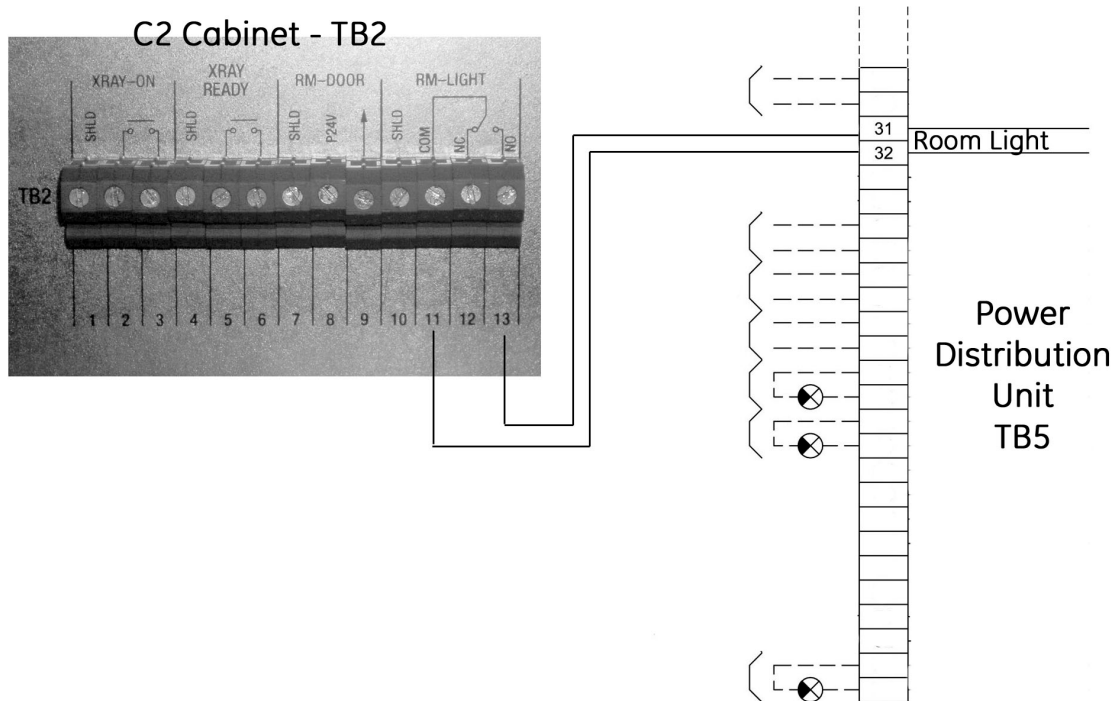

5.12.1.3 Room Lighting for System

Figure 111

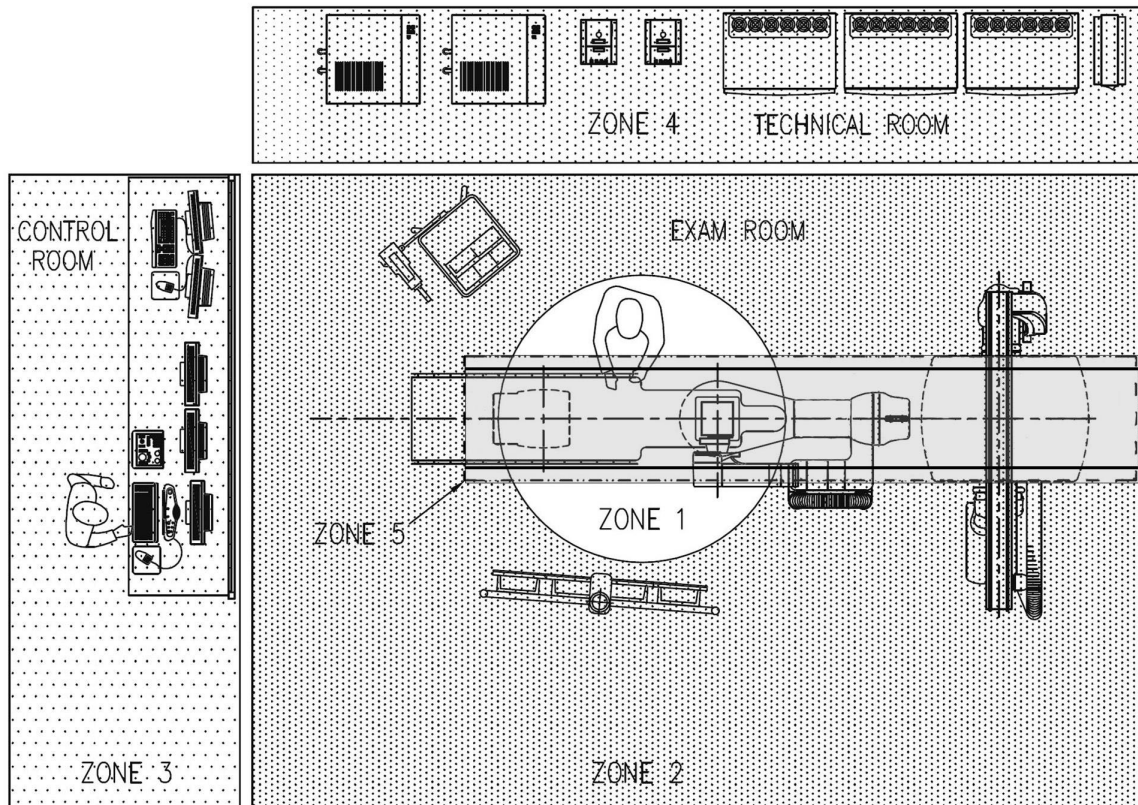

Zone 1: Intensive lighting needed by operator. Manually cut not located at false ceiling level.

Zone 2: Variable lighting without specular reflection on display and monitor screens. Indirect lighting but preferable from ceiling. Automatically cut by the Innova system.

Zone 3: Variable lighting without artifact on display and monitor screens. manually cut.

Zone 4: Normal lighting manually cut. (For maintenance).



NOTICE

Zone 5: Nothing is permitted in this zone, that means:

- no mounting hardware can protrude below the finished ceiling height (top surface of gantry stationary rails), such as Unistrut mounting bolts, support brackets, sprinklers, air vents, etc.

5.12.1.4 Windows and curtains

When the examination room has a window with an aperture outside of the controlled light area (day light, other...) a curtain has to maintain the light intensity under a limit fixed to 150 lux.

NOTE

In Germany: Ambient luminance of 100 lux maximum is required to maintain Exam Room class 2 according to DIN 6868-157.

Chapter 6 Communication Requirements

6.1 Network Requirements

6.1.1 General Information

The system is provided with a firewall unit, that allows connection to the hospital network for pushing the DICOM images or for service remote access (InSite). This firewall is compatible with 10/100/1000 (Gigabit Ethernet) networks.

The C-FRT Cabinet provides an Ethernet RJ45 plug, the hospital is responsible for providing the Ethernet cable between the system and the hospital network.

For complete descriptions of these connectivity solutions, please refer to the Broadband Solutions catalogue available through your local GEHC sales and service representative.

Connectivity Process and pre-installations checklists are available in the Broadband Connectivity PIM available through your local GEHC sales and service representative.

6.1.2 InSite Connection

InSite requires a VPN connection to the system. To create this connection, the system IP and site IT contact information, should be given to your local GEHC sale and service representative before the system installation begins. Once submitted, a member of the GEHC Broadband Solutions team will contact the site IT to set up the VPN connection.

The SupportCentral links where information from the InSite Connectivity Team or Insite Request Form can be found are:

- **Americas:** http://supportcentral.ge.com/products/sup_products.asp?prod_id=73661
- **Asia:** http://supportcentral.ge.com/products/sup_products.asp?prod_id=19181
- **Europe:** http://supportcentral.ge.com/products/sup_products.asp?prod_id=24026

6.1.3 IP Addresses

IP addresses for DL and AW PCs have to be requested to the Hospital IT at the time of pre-install to not delay the installation.

New requirements related to the Privacy and Security configurations also apply with the new system software generation. Refer to [6.2 Privacy and Security Configuration on page 179](#).

6.2 Privacy and Security Configuration

The new Privacy and Security features available with the System require to be configured according to the security policy requested by the hospital.

To ensure the installation is successful and is not delayed because of missing information, it is required to gather all needed information as part of the pre-install process.

The typical parameters are the one listed below. The complete list is provided in Tab "Security Configuration" of the document *IGS System Installation Prerequisites - DOC2024755*. See also Important Notice below.

- **Machine Account**
- **User Authentication**
- **Authorization**
- **Audit Trail**
- **Malware protection**
- **Network Security**
- **Data Transmission**
- **Other Requirements**



NOTICE

- Always refer to the detailed Checklist provided in the document *IGS System Installation Prerequisites - DOC2024755* available from MyWorkshop. Always use the last revision which will contain all mandatory updates.
- For details on the new Privacy and Security features available with this machine, refer to the document *Privacy and Security Guide - DOC1972949* available from MyWorkshop.
- Support on Privacy and Security can also be found here (USCAN only): http://supportcentral.ge.com/products/sup_products.asp?prod_id=259836.



Innova™ IGS 6