



Revolution Discovery CT

Pre-Installation Manual

This manual supports the following products:

- Revolution Discovery CT with Revolution GSI and Revolution HD configurations
- Revolution HD
- Discovery CT
- Discovery CT750 HD

5220253-1EN
Revision 22

Language Policy

DOC0371395 - Global Language Procedure

ПРЕДУПРЕЖ ДЕНИЕ (BG)	Това ръководство е налично само на китайски (ZH-CN), английски, френски, немски, японски, корейски, полски, португалски (PT-BR), руски, испански и виетнамски. Ако доставчикът на услуги на даден клиент изисква език, който е различен от тези езици, отговорност на клиента е да предостави преводачески услуги.
警告 (ZH-CN)	本手册仅提供中文 (ZH-CN)、英文、法语、德语、意大利语、日语、韩语、波兰语、葡萄牙语 (PT-BR)、俄语、西班牙语和越南语版本。如果客户的服务提供商需要其他语言，则客户有责任提供翻译服务。
警告 (ZH-HK)	本手冊僅提供中文 (ZH-CN)、英文、法文、德文、意大利文、日文、韓文、波蘭文、葡萄牙文 (PT-BR)、俄文、西班牙文及越南文版本。如客戶的服務供應商需要這些語言以外的版本，則相關客戶有責任提供有關的翻譯服務。
警告 (ZH-TW)	此手冊僅提供中文 (ZH-CN)、英文、法文、德文、義大利文、日文、韓文、波蘭文、葡萄牙文 (PT-BR)、俄文、西班牙文和越南文版本。假如客戶的服務提供者所需語言版本不在所列語言之中，客戶需自行負責提供翻譯服務。
UPOZORENJE (HR)	Ovaj je priručnik dostupan samo na kineskom (ZH-CN), engleskom, francuskom, njemačkom, talijanskom, japanskom, korejskom, poljskom, portugalskom (PT-BR), ruskom, španjolskom i vijetnamskom jeziku. Ako klijentov serviser zahtijeva jezik koji nije jedan od tih jezika, odgovornost je klijenta pružiti uslugu prevođenja.
VÝSTRAHA (CS)	Tato příručka je k dispozici pouze v čínštině (ZH-CN), angličtině, francouzštině, němčině, italštině, japonštině, korejštině, polštině, portugalštině (PT-BR), ruštině, španělštině a vietnamštině. Pokud poskytovatel služeb zákazníka vyžaduje jiný jazyk než tyto jazyky, je odpovědností zákazníka poskytovat překladatelské služby.
ADVARSEL (DA)	Denne vejledning findes kun på kinesisk (ZH-CN), engelsk, fransk, tysk, italiensk, japansk, koreansk, polsk, portugisisk (PT-BR), russisk, spansk og vietnamesisk. Hvis en kundes tjenesteudbyder kræver et andet sprog end disse sprog, er det kundens ansvar at levere oversættelsestjenester.
WAARSCHUWING (NL)	Deze handleiding is alleen beschikbaar in het Chinees (ZH-CN), Engels, Frans, Duits, Italiaans, Japans, Koreaans, Pools, Portugees (PT-BR), Russisch, Spaans en Vietnamees. Als de serviceprovider van een klant een andere taal dan deze talen vereist, is het de verantwoordelijkheid van de klant om vertaalservices te leveren.
WARNING (EN)	This manual is available in Chinese (ZH-CN), English, French, German, Italian, Japanese, Korean, Polish, Portuguese (PT-BR), Russian, Spanish, and Vietnamese only. If a customer's service provider requires a language other than these languages, it is the customer's responsibility to provide translation services.
HOIATUS (ET)	See juhend on saadaval ainult hiina (ZH-CN), inglise, prantsuse, saksa, itaalia, jaapani, korea, poola, portugali (PT-BR), vene, hispaania ja vietnami keeles. Kui kliendi teenusepakkujal on vaja juhendit mõnes muus keeles, on tõlketeenuste osutamine kliendi kohustus.
VAROITUS (FI)	Tämä opas on saatavilla vain kiinaksi (ZH-CN), englanniksi, ranskaksi, saksaksi, italiaksi, japaniksi, koreaksi, puolaksi, portugaliksi (PT-BR), venäjäksi, espanjaksi ja vietnamiksi. Jos asiakkaan palveluntarjoaja edellyttää muuta kuin näitä kieliä, käänöspalveluiden tarjoaminen on asiakkaan vastuulla.
ATTENTION (FR)	Ce manuel est disponible uniquement en allemand, anglais, chinois (ZH-CN), coréen, espagnol, français, italien, japonais, polonais, portugais (PT-BR), russe et vietnamien. Si le prestataire de services d'un client nécessite que le manuel soit rédigé dans une autre langue que celles mentionnées ci-dessus, il incombe au client de le faire traduire.
WARNUNG (DE)	Dieses Handbuch ist nur auf Chinesisch (ZH-CN), Englisch, Französisch, Deutsch, Italienisch, Japanisch, Koreanisch, Polnisch, Portugiesisch (PT-BR), Russisch, Spanisch und Vietnamesisch verfügbar. Wenn ein Dienstleister des Kunden dieses in einer anderen Sprache als die genannten benötigt, liegt es in der Verantwortung des Kunden, Übersetzungsdienstleistungen zu erbringen.

ΠΡΟΕΙΔΟΠΟΙΗΣΗ (EL)	Αυτό το εγχειρίδιο είναι διαθέσιμο μόνο σε Κινεζικά (ZH-CN), Αγγλικά, Γαλλικά, Γερμανικά, Ιταλικά, Ιαπωνικά, Κορεατικά, Πολωνικά, Πορτογαλικά (PT-BR), Ρωσικά, Ισπανικά και Βιετναμέζικα. Εάν ο πάροχος υπηρεσιών ενός πελάτη απαιτεί γλώσσα που δεν συμπεριλαμβάνεται σε αυτές τις γλώσσες, αποτελεί ευθύνη του πελάτη να παρέχει υπηρεσίες μετάφρασης.
FIGYELMEZTETÉS (HU)	Ez a kézikönyv az alábbi nyelveken érhető el: angol, francia, japán, kínai (ZH-CN), koreai, lengyel, német, olasz, orosz, portugál (PT-BR), spanyol és vietnámi. Ha az ügyfél szolgáltatója ezektől eltérő nyelvű kézikönyvet szeretne, akkor az ügyfél feladata, hogy gondoskodik a megfelelő fordításról.
AÐVÖRUN (IS)	Þessi handbók er aðeins fánleg á kínversku (ZH-CN), ensku, frönsku, þýsku, ítölsku, japönsku, kóresku, pólsku, portúgölsku (PT-BR), rússnesku, spænsku og víetnömsku. Ef þjónustuaðili viðskiptavinar þarfnast annars tungumáls en þessara tungumála er það á ábyrgð viðskiptavinarins að veita þýðingarþjónustu.
AVVERTENZA (IT)	Questo manuale è disponibile solo in lingua cinese (ZH-CN), inglese, francese, tedesco, italiano, giapponese, coreano, polacco, portoghese (PT-BR), russo, spagnolo e vietnamita. Qualora un fornitore di servizi del cliente richieda una lingua diversa dall'inglese, sarà responsabilità del cliente fornire il servizio di traduzione corrispondente.
警告 (JA)	このマニュアルは、中国語 (ZH-CN)、英語、フランス語、ドイツ語、イタリア語、日本語、韓国語、ポーランド語、ポルトガル語 (PT-BR)、ロシア語、スペイン語、およびベトナム語のみで提供されています。お客様のサービスプロバイダがこれらの言語以外の言語を必要とする場合は、お客様の責任において翻訳サービスを提供してください。
경고 (KO)	이 설명서는 중국어(중국어-중국), 영어, 프랑스어, 독일어, 이탈리아어, 일본어, 한국어, 폴란드어, 포르투갈어(포르투갈어-브라질), 러시아어, 스페인어, 베트남어로만 제공됩니다. 고객의 서비스 제공자가 이 언어를 제외한 다른 언어를 요구하는 경우, 번역 서비스를 제공하는 것은 고객의 책임입니다.
BRĪDINĀJUMS (LV)	Šī rokasgrāmata ir pieejama tikai ķīniešu (ZH-CN), angļu, franču, vācu, itāliešu, japāņu, korejiešu, poļu, portugāļu (PT-BR), krievu, spāņu un vjetnamiešu valodā. Ja klientu apkalpošanas speciālistam ir nepieciešama cita valoda, kas atšķiras no šeit norādītajām, klienta pienākums ir nodrošināt tulkotājas pakalpojumu.
ĮSPĖJIMAS (LT)	Šis vadovas pateikiamas tik kinų (ZH-CN), anglų, prancūzų, vokiečių, italų, japonų, korėjiečių, lenkų, portugalų (PT-BR), rusų, ispanų ir vietnamiečių kalbomis. Jei klientų paslaugų teikėjui reikalinga kita nei šios kalba, už vertimo paslaugų suteikimą atsako klientas.
ADVARSEL (NO)	Denne håndboken er bare tilgjengelig på kinesisk (ZH-CN), engelsk, fransk, tysk, italiensk, japansk, koreansk, polsk, portugisisk (PT-BR), russisk, spansk og vietnamesisk. Hvis en kundes tjenesteleverandør krever et annet språk, er det kundens ansvar å levere en oversettelsestjeneste.
OSTRZEŻENIE (PL)	Niniejsza instrukcja jest dostępna wyłącznie w języku chińskim (ZH-CN), angielskim, francuskim, niemieckim, włoskim, japońskim, koreańskim, polskim, portugalskim (PT-BR), rosyjskim, hiszpańskim i wietnamskim. Jeśli usługodawca klienta wymaga języka, który nie został wymieniony powyżej, obowiązkiem klienta jest zapewnienie usług tłumaczeniowych.
ATENÇÃO (PT-BR)	Este manual está disponível somente em chinês (ZH-CN), inglês, francês, alemão, italiano, japonês, coreano, polonês, português (PT-BR), russo, espanhol e vietnamita. Se o prestador de serviços de um cliente necessitar de um idioma diferente dos mencionados, o fornecimento dos serviços de tradução é de responsabilidade do cliente.
ATENÇÃO (PT-PT)	Este manual está disponível apenas em alemão, chinês (ZH-CN), coreano, espanhol, francês, inglês, italiano, japonês, polaco, português (PT-BR), russo e vietnamita. Se o fornecedor de serviços de um cliente necessitar de um idioma diferente dos listados aqui, é da responsabilidade do cliente assegurar os serviços de tradução.
ATENȚIE (RO)	Acest manual este disponibil numai în limbile chineză (ZH-CN), engleză, franceză, germană, italiană, japoneză, coreeană, poloneză, portugheză (PT-BR), rusă, spaniolă și vietnameză. Dacă furnizorul de servicii al unui client solicită o limbă diferită față de aceste limbi, este responsabilitatea clientului să furnizeze servicii de traducere.

ОСТОРОЖНО! (RU)	Настоящее руководство доступно только на китайском (ZH-CN), английском, французском, немецком, итальянском, японском, корейском, польском, португальском (PT-BR), русском, испанском и вьетнамском языках. Если поставщику услуг заказчика требуется руководство на каком-либо другом языке, перевод руководства на необходимый язык осуществляется стороной заказчика.
UPOZORENJE (SR)	Ovaj priručnik dostupan je samo na kineskom (ZH-CN), engleskom, francuskom, nemačkom, italijanskom, japanskom, korejskom, poljskom, portugalskom (PT-BR), ruskom, španskom i vijetnamskom jeziku. Ako korisnik kao pružalac usluge zahteva neki drugi jezik od navedenih, njegova je dužnost da obezbedi prevod.
UPOZORNENIE (SK)	Táto príručka je dostupná len v nasledovných jazykoch: čínština (ZH-CN), angličtina, francúzština, nemčina, taliančina, japončina, kórejščina, poľština, portugalčina (PT-BR), ruština, španielčina a vietnamčina. Ak poskytovateľ služieb daného zákazníka požaduje iný ako tieto jazyky, za poskytnutie prekladateľských služieb zodpovedá zákazník.
ATENCIÓN (ES)	Este manual está disponible solo en chino (ZH-CN), inglés, francés, alemán, italiano, japonés, coreano, polaco, portugués (PT-BR), ruso, español y vietnamita. Si el proveedor de servicios de un cliente requiere un idioma distinto de estos idiomas, es responsabilidad del cliente proporcionar los servicios de traducción.
VARNING (SV)	Den här manualen finns endast tillgänglig på kinesiska (ZH-CN), engelska, franska, tyska, italienska, japanska, koreanska, polska, portugisiska (PT-BR), ryska, spanska och vietnamesiska. Om en kunds tjänsteleverantör behöver ett annat språk än dessa är det kundens ansvar att ordna med översättningstjänster.
OPOZORILO (SL)	Ta priročnik je na voljo v kitajščini (ZH-CN), angleščini, francoščini, nemščini, italijanščini, japonščini, korejščini, poljščini, portugalščini (PT-BR), ruščini, španščini in vietnamščini. Če kupčev ponudnik storitev potrebuje drug jezik, mora za prevod poskrbeti kupec.
DİKKAT (TR)	Bu kılavuz yalnızca Çince (ZH-CN), İngilizce, Fransızca, Almanca, İtalyanca, Japonca, Korece, Lehçe, Portekizce (PT-BR), Rusça, İspanyolca ve Vietnamca dillerinde mevcuttur. Müşteri servis sağlayıcısı bu dillerden başka bir dil talep ederse çeviri hizmeti sağlamak müşterinin sorumluluğundadır.
ЗАСТЕРЕЖЕННЯ (UK)	Цей посібник доступний лише китайською (ZH-CN), англійською, французькою, німецькою, італійською, японською, корейською, польською, португальською (PT-BR), російською, іспанською та в'єтнамською мовами. Якщо постачальник послуг замовника використовує мову, яку не вказано у цьому переліку, послуги з перекладу має забезпечити замовник.

Revision History

The information in this manual applies to the following systems:		
<ul style="list-style-type: none"> • Revolution Discovery CT with Revolution GSI and Revolution HD configurations • Revolution HD • Discovery CT • Discovery CT750 HD 		
Rev	Date	Reason for Change
22	20-August-2025	<p>Chapter 1: Update Pre-Installation Checklist per DOC1809666_r9.</p> <p>Chapter 6: Delete incorrect ceiling height information in Table 6-1 based on Feedback7374. Add AVIMOS Camera in Patient Environment.</p> <p>Chapter 7: Update the length of Table to maximum extension head end with extender from Center line in Table 7-1 and Figure 7-1.</p> <p>Chapter 8: Update the Figure 8-7: Center of Gravity (CG) for Boom-in-Room Kit- (B7877RU kit) Add cable length in Figure 8-24 RCK-AVIMOS Schematics Diagram. Add floor strength information. Update Figure 2106573 (8 in.) Anchor Bolt and 5487992-2 / 5874830-2 (7 in.) Anchor Bolt (lock ring only for Gantry).</p> <p>Chapter 9: Add EMC 4.1 information based on DOC2947691.</p> <p>Chapter 12: Update grounding description according to HPM feedback. Update Feeder wires size based on DOC3061766, based on feedback5833.</p> <p>Chapter 13: Update wires size based on DOC3061766, based on feedback5833. Delete BEVCO information based on feedback6092, FE can refer DOC2058932 from SIMS. update "Scan Room Warning Light and Door Interlock" based on feedback14133.</p> <p>Chapter 14: Add a note about Fork-lift Truc. Update lifting description per SPRHCSDM00720264.</p> <p>Chapter 15: Update Flat-bed Truck Removal, Tilting not approved for Flat-bed Truck. Common issue, follow TaiX to update.</p>

21	20-June 2022	<p>Chapter 3: Update tilt bed truck to forklift</p> <p>Chapter 8: Update GE Site CAD Drawing with Alignment tool (5824714) Add warning under the figure 8-5 and figure 8-11 Add B7877RU kit ceiling information add Ceiling Requirement for Auto Patient Positioning Depth Camera add Ceiling Requirement for AVIMOS Camera Update Gantry/Table anchoring information</p> <p>Chapter 9: Update EMI information</p> <p>Chapter 11: Added Digital Service and Connectivity Requirements</p> <p>Chapter 14: Update tilt-bed truck to forklift</p>
20	24-Sep-2020	<p>Update Pre-Installation Checklist</p> <p>Chapter 6: Update console notice according to SPR HCSDM00627199</p> <p>Chapter 8: Update Ceiling requirement</p> <p>Chapter 13: Update cable length according to SPRHCSDM00602307 Update A1 and UPS Information according to system PCM</p>
19	10-July 2019	<p>Chapter 8: Updated Illustration 8-12 Seismic Anchor for PDU Updated Illustration 8-16 Seismic bracket for Z8G4 Updated Illustration 8-19 Table Center of Gravity</p>
18	07-March 2019	<p>Chapter 7: Added Z8G4 information</p> <p>Chapter 8: Added Z8G4 information</p> <p>Chapter 9: Added EMC4.0 information on section 1.6</p>
17	28-April 2018	<p>Chapter 12: Updated Table 12-1 Minimum Recommended Circuit Pro- Protection Rating value according to SPRHCSDM00473698</p> <p>Chapter 13: Added new A1 information</p>

16	28-June 2017	<p>Chapter 5: Updated Table 5-2</p> <p>Chapter 6: Updated description on Room Layout B</p> <p>Chapter 7: Add the open console information on section 1.2</p> <p>Chapter 8: Add the open console information on section 1.4, Table 8-2</p> <p>Chapter 14: Add the open console information on section 1.5</p>
15	23-May 2016	<p>Chapter 9: Updated section 1.2 cooling requirement for NIOHD64 console</p>
14	04-Dec 2015	<p>Chapter 1: Updated name of system to Revolution Discovery CT.</p> <p>Chapter 8: HCSDM00319779: Updated Table 8-2 Gantry Weight for Gantry with covers_LCD Panel</p> <p>Added new anchor information (5487992-2) on Table 8-3, Table 8-4. Added Illustration 8-7 Gantry and Table Anchoring with 5487992-2 anchor bolt</p> <p>Chapter 14: Added Rigging statements</p>
13	April 2014	<p>Chapter 1: Updated name of system to Discovery CT Series. HCSDM00184991: Updated Pre-Install Checklist on optional storage cabinet.</p> <p>Chapter 6: Updated Room Sizes Increased minimum room sizes. IEC Compliance information changes and grammatical errors.</p> <p>Chapter 7: Added illustration 7-3 Front Cover with Service Dolly Dimensions (Gantry with LCD Panel)</p> <p>Chapter 8: Updated Gantry Weight information on Table 8-2, add illustration 8-11Center-of-Gravity Gantry with LCD Panel Updated GT Table Weight information on Table 8-2</p>

12	11-Apr., 2013	<p>Chapter 1: Added Action Item for optional storage cabinet to <i>Pre-Install Checklist</i>. HCS DM00184991 - Chapter 1: Indicated optional modem applies to GOC6 and earlier consoles. HCS DM00194542 - Chapter 3 Sec 1.3.3: Reworded floor system tolerance. Chapter 6: Updated room sizes in Table 6-1. Chapter 14 Sec. 1-6: Updated temperature range and maximum humidity values. Chapter 5 Sec. 1.5: Changed wording from “Storage Cabinet” to “Service Equipment Storage”; added information related to optional storage cabinet. HCS DM00174690 - Chapter 9: Updated equipment room temperature limits. HCS DM00118272 - Chapter 12: Updated system power requirements. Chapter 13: Removed references to UPS Long Cables in Table 13-7 (now Table 13-9). Per HCS DM00165236, added console Long Cable Collector info and new Table 13-4 and Table 13-6 to support this collector. Per HCS DM00186521, updated cable lengths for runs 100, 101, 102, and 103. Per HDe3 NPI, added references to alternate audible x-ray on alert.</p>
11	9-August 2012	Corrected typo in Chapter 6 - Minimum Room Size.
10	Nov 28, 2011	HCS DM00108552 HCS DM001044557 HCS DM00096594
9	17-May, 2011	HCS DM045978 - Chapter 9 Sec 5.1 Units of measure updated. HCS DM036708 - Anchor Measurements updated.
8	12-Oct., 2010	FCTge53185 - Table 9-3. FCTge59350 - Added Boom Assembly Clearance statement
7	29-Oct., 2009	PS #52 - EMI Clearance Chapter 9, Sec 5.3 and Fig 9-3 FCTge50539 new clearances, front cover removal and elimination of egress specifications Chapter 4 Sec 1.2 Fig 4-1 Table 4-4 Sec 2.0 Chapter 5, Fig 5-1, Sec 2.1 Chapter 6 Sec 1.2.1 Appendix A FCTge51303 - REmoved Seismic Option Kit R4390JC, Chapter 8 Sec 6.1 Per Program Updates: kVA updates - Chapter 9, Table 9-3 and Chapter 12 Sec 2.2. and 3.3.
6	24-Aug., 2009	Finding 53 (Powersuite), New language updates, surface penetration permit to check list, Chapter 7 added ceiling to floor clearances, Chapter 8 added warnings.
5	19-May, 2009	Per NPi Program, removed all references to VCT.
4	19-Nov., 2008	FCTge43607 - <i>Floor Vibration Specifications</i>
3	8-Oct., 2008	Updated per FCTge40232, and per FCTge41654.
2	20-Aug., 2008	Updated cover art, name, tables, Interconnect drawings, cooling requirements, and service clearance requirements. Added new languages in Precautions. Completed updates to make this document compatible for LightSpeed VCT w/ GOC6 and Discovery CT750 HD. Chapter 5, Section 1.0: Updated measuring service clearances. Chapter 14, Section 3.2: Updated GE Healthcare supplied cables (long).
1	17-March 2008	Initial Release for NPI.

Page intentionally left blank

Contents

Chapter 1 Introduction	13
1.1 Introduction.....	13
1.2 Pre-Installation Checklist.....	16
Chapter 2 Installation Type	17
2.1 Installation Types	17
Chapter 3 System Siting Requirements.....	21
3.1 System Siting Requirements.....	21
Chapter 4 Regulatory Requirements.....	27
4.1 Regulatory Requirements	27
4.2 Regulatory Clearances	28
Chapter 5 Service Clearance Requirements.....	29
5.1 Service Clearance Requirements.....	29
Chapter 6 Room Sizes	35
6.1 Room Sizes	35
Chapter 7 System Component Dimensions.....	43
7.1 System Component Dimensions	43
Chapter 8 Structural and Mounting Requirements.....	57
8.1 Structural and Mounting Requirements.....	57
Chapter 9 Environmental Requirements.....	107
9.1 Environmental Requirements.....	107
Chapter 10 Radiation Protection Requirements.....	123
10.1 Radiation Protection Requirements.....	123
Chapter 11 Network Requirements	127
11.1 Network Requirements	127
Chapter 12 Power Requirements.....	131
12.1 Power Requirements.....	131
Chapter 13 Interconnection Data	137
13.1 Interconnection Data	137
Chapter 14 Delivery and Storage Requirements.....	151
14.1 Delivery and Storage Requirements.....	151
Chapter 15 Handling Requirements.....	159
15.1 Handling Requirements	159

Appendix A Regulatory Clearances for US 161

- A.1 Regulatory Clearances161
- A.2 Minimum Regulatory Workspace Clearances by Major Subsystem162
- A.3 How to Measure.....164

Appendix B Alternate Cover Removal Option..... 167

Chapter 1 Introduction

1.1 Introduction

Using the Pre-Installation Manual

This manual is the official source of prerequisites to install a General Electric (GE) Computed Tomography (CT) system. Topics covered are site planning, site preparation, and the system requirements. This manual is divided into requirements for the customer, the system, the environment and on-site construction. It also includes the importance of addressing the local and national regulatory requirements, which may be specific to your location.

A GE Project Manager (PM) will be available for specific questions or concerns. The PM's primary responsibility is to assist the customer with the siting requirements. This manual is a guide toward the preparation for your GE CT system. Prior to any construction or installation, GE Headquarters Architectural Planning must approve the completeness of all preliminary concepts, site plans, and final working drawings.

Pre-installation includes the procurement and installation of required materials, and services necessary for the installation and startup of a CT system.

Assigning a Site Project Coordinator

It is the customer's (purchaser's) responsibility to assign a site project coordinator. The site project coordinator is the primary contact and liaison between with the construction planners, architects, contractors, and any other site administrative personnel for all site related functions; reporting to the purchaser.

The primary responsibility of the site project coordinator, working closely with GE , is to ensure the purchaser upholds all requirements outlined in this manual. To ensure a successful installation, it is recommended that the site project coordinator manage the entire project from pre-install to final startup and be familiar with all phases of pre-installation and installation of similar medical device construction projects. The site project coordinator should read and understand the contents of this manual and be familiar with the installation procedures.

Customer Responsibility

It is the responsibility of the customer to prepare the site in accordance with all the specifications provided in this manual and be familiar with site-specific drawings and applicable regulations. Consideration should be taken for future expansion during the design phase of the site. It is essential to verify all aspects of the site configuration before construction has begun, as subsequent changes can be costly or impractical.

Pre-Install Checklist A detailed pre-installation checklist is provided in this manual, see Customer Pre-Installation Checklist. It is the responsibility of the customer to ensure all requirements on the checklist are fulfilled and that the site conforms to all specifications and requirements detailed in this manual.

Planning and Design Work The customer will select the location of the site. All architectural, mechanical, and electrical drawings associated with the design and planning of the site are the responsibility of the customer. Any alterations or modifications to the drawings or to products not specifically included in the sales contract are the customer's responsibility. The customer shall provide

the site project coordinator, a clean and safe work environment including proper lighting. All floors, walls and ceiling should be in a finished state prior to installation, and all site-construction renovation completed.

Regulatory Compliance The customer shall be solely responsible for all regulatory compliance. All work shall comply with national, state and local regulatory and building codes for the location in which the installation occurs. This includes but is not limited to: permits, inspections, radiation licensing, fire control devices, earthquake regulations, international building codes, service, structural, flooring, vibration, HVAC, electrical, IT network, radiation protection, operational clearance requirements, and all applicable codes.

Electrical Requirements The customer shall be solely responsible for providing all electrical material and service required as outlined and illustrated in this publication. This includes but is not limited to: Installation of all properly-sized junction boxes, outlets with covers, line safety switches, and fittings installed at the locations specified in the site design. Supplying electrical power of the required voltage, all necessary power supply cables and grounds, all necessary power cables and grounds to the PDU, and an Emergency-Off switch in the scan room.

**NOTE**

GE does not provide or install conduits, junction boxes, or ducting illustrated in this publication. GE only supplies part of the wires in this publication and customers have to supply the rest of wires.

Accessory Installation Accessories ordered for use on the CT system come with their own service manual and installation instructions provided by the OEM (non-GEHC) supplier. For items not installed by GE Service, the customer must ensure that the accessory is installed per OEM specifications. For ceiling, wall or floor mounted accessories ensure the item is mounted properly and will not be a hazard to users. GE is not responsible for the contents and accuracy of the non-GEHC supplied OEM installation manual.

For items installed by GE Service but for which the pre-installation is under customer responsibility, customer must ensure that the pre-installation work is performed per OEM specifications. For any ceiling, wall or floor support structure part of the pre-installation requirement, the customer must ensure those structures have been validated by a mechanical engineer. GE is not responsible for the contents and accuracy of the non-GEHC supplied OEM installation manual.

Roles and Responsibilities

- **Customer** : Also known as Buyer or Purchaser or End User. This is the entity that has entered into contract with GE to buy the product.
- **GE Salesperson** : Responsible for completing the customer order process. They coordinate the completion of customer order as desired by the customer, for the customer. They are responsible for correcting incorrect orders. Changing orders, coordinating any replacement of damage in shipment items and for resolving missing in shipment issues.
- **GE Project Manager (PM)** : Responsibilities include the overall project coordination and site planning of GE products; manages activities cross-functionally with sales, customer, customer contractors, and local field teams to ensure customer site is designed and prepared to accept and install product in the facility.
- **GE Field Engineer** : GE field personnel responsible for the actual assembly, installation, calibration of the product and verification of the proper operation and configuration of the GE product. This may include the physical movement of the system and its subcomponents from the point of delivery to the scan suite.

- **Mechanical Installer** : Individuals trained to perform all the tasks to mechanically install the system subcomponents. These individuals may be GE personnel or 3rd party contractors hired by and trained to perform these tasks by GE.
- **Zone Broadband Specialist** : GE personnel responsible for providing IT expertise and maintaining records of specific network IT connectivity parameters that are required to properly configure the products' connection to the broadband connection provided by the customer.
- **Network IT Personnel** : Dedicated on site personnel affiliated with or contracted by the customer. Responsible for providing IT expertise necessary to ensure successful network IT connectivity between the GE product and the facility.
- **Qualified Electrician** : Also known as Electrical Contractor. Qualified (Certified by a regulatory agency), In-House individual or entity contracted by the customer. Responsible for electrical connections between customer power source and up to and including the final connection to the GE product.
- **Architectural Engineer** : Dedicated on site personnel affiliated with the customer or contracted by the customer to manage the details of the construction parameters defined by regulatory agencies and as defined by parameters in the GE Pre-installation manual for the proper installation of the GE product.
- **Structural Engineer** : Dedicated on site personnel affiliated with the customer or contracted by the customer to manage the details of the structural parameters defined by regulatory agencies and as defined by the structural parameters provided in the GE Pre-installation manual for the proper installation of the GE product.
- **HVAC Design Engineer** : Dedicated on site personnel affiliated with the customer or contracted by the customer to manage the details of the air conditioning and air handling parameters defined by regulatory agencies and as defined by parameters in the GE Pre-installation manual for the proper installation of the GE product.
- **Independent Contractor** : Person or entity who contracts to do work for another person according to his or her own processes and methods; the contractor is not subject to another's control except for what is specified in a mutually binding agreement for a specific job. Can be contracted by GE personnel or by the customer for a unique or special task as part of the GE product installation process.
- **Customer provided Project Coordinator** : Dedicated contact person that works with GE Project Manager (PM). Acts as the single point of contact for the customer. Coordinates with all persons or entities contracted by the customer for the successful installation of a GE product.
- **Rigger** : Person, persons or entity hired as an Independent Contractor to perform a specific task related to the movement of GE product from the point of delivery to the scan suit where it will be installed.

Installation Forms

It will be the responsibility of the PM to ensure the following forms are filled out completely and correctly by the proper personal and submitted prior to the end of the installation of the machine.

Form	Description
System Installation Checklist	Used for capturing Customer Information and Hospital System details. More detailed information maybe required than this form provides, and can be added to the form as needed. Printable for use.
Mechanical Installation Completion Check-list	This check list captures all steps required for Mechanical completion.

e4879 Installation Form	The e4879 form is an internal GE form and must be submitted globally every time a system is installed or certified component is replaced. This is not a regulatory form but is required by GE Healthcare. This form is an Excel worksheet and includes Four (3) parts, located on the tabs in Excel. The three parts to be completed are: <ul style="list-style-type: none"> • COMPLIANCE • MECHANICAL INSTALL • ELECTRICAL INSTALL
GE FORM—System Chassis Leakage Test Form (DOC0594445)	A “working” document that can be printed. All information is required to be transcribed to the e4879 Form
Floor Levelness Measurement Form (DOC1766027)	Used for PM to record the floor levelness measurement prior to the installation

1.2 Pre-Installation Checklist

To ensure the latest revision is used, locate DOC2949059 on SIMS Content Viewer.

Chapter 2 Installation Type

2.1 Installation Types

How to Determine the Best Installation Type for Your Site

Discuss installation options with your PMI to determine which of the installation types listed below best fits your site and schedule.

- [Typical Installations on page 17](#) Typical Installations
- [Construction Site Installations on page 17](#) Construction Site Installations
- [Re-locatable Building Installations on page 18](#) Re-locatable Installations
- [Upgrade Installations on page 19](#) Upgrade Installations
- [Quick Installations on page 19](#) Quick Installations
- [Two-Step \(Temporary\) Installations on page 19](#) Two-Step (Temporary) Installations

Typical Installations

Typical installations occur at established sites with finished, dust-free, occupancy-ready scan suites. The rooms range from suggested to minimum room sizes, and have NO ongoing construction on-site. A typical installation allows customers flexibility for room upgrades and site improvements. Upgrades and improvements may require additional planning prior to system delivery, especially when involving:

- Seismic approval
- Floor structural improvements
- HVAC improvements
- Electrical improvements
- Review of scan room shielding requirements by a qualified radiological health physicist.

As with any installation, the final site design for a typical installation must meet all service and regulatory requirements detailed in this manual.

Construction Site Installations

A *construction installation* describes installation at sites without an occupancy permit, often with ongoing construction. In general, construction sites fail to meet the recommended specifications for delivery of the system. GE Healthcare does not recommend construction installations, as they can result in delays, increased costs, and possible damage to the system. When construction-site delivery proves unavoidable, the installation falls into one of two categories.

- Full construction site with completed radiology area.
- Full construction site with limited delivery access.

Review the following categories to determine which most closely matches the condition of the planned installation site.

Full Construction Site with Completed Radiology Area

This type of site consists of a finished, dust-free, occupancy-ready radiology suite. While there is no remaining construction in or around the scan suite area, there may be ongoing construction in other areas. At the time of delivery such sites feature:

- Dust control measures deployed in the radiology suite area.
- Scan suite access limited to a single entrance. See [Figure 2-1 Full construction site with completed radiology area. on page 18.](#)
- Radiology suite sealed off from the remaining construction area.
- Operational HVAC, with a positive air pressure within the radiology suite.

In addition the radiology suite at such a site REMAINS in a dust-free, occupancy-ready state after delivery and throughout the remaining construction phase.

Figure 2-1 Full construction site with completed radiology area.

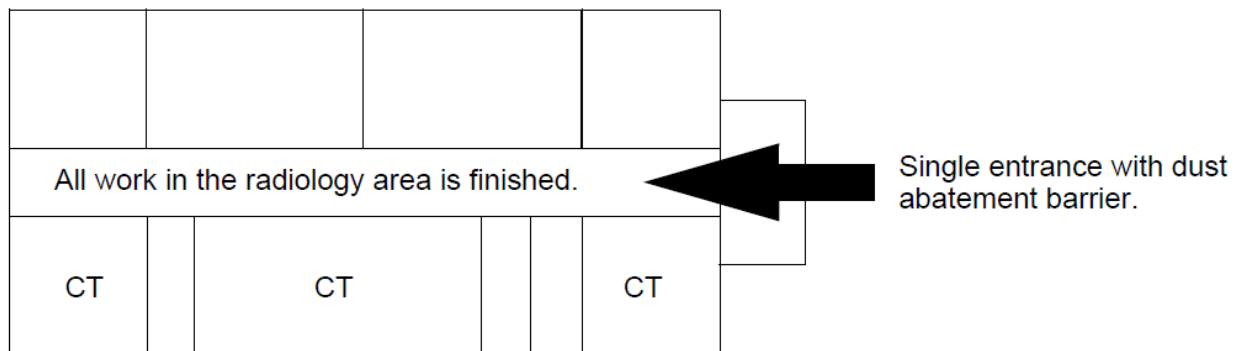

Full Construction Site with Limited Delivery Access

This type of site allows delivery during ongoing construction of the radiology suite area. At such sites, delivery occurs prior to site completion, but the product remains stored until a finished, dust-free, occupancy-ready radiology suite area is ready. This type of site requires the CT scanner to be delivered in a sealed package with dollies. Delivery to the storage area may require a lift truck or riggers. Installation work begins only when the site reaches the completed, dust-free, occupancy-ready radiology suite requirement.



NOTE

If delivery requires vertical or horizontal lifting, the PMI adds the necessary identifier to the order.

Re-locatable Building Installations

A re-locatable building is made in a factory and delivered to the site of its permanent location. Re-locatable buildings qualify as fixed sites and must satisfy all of the requirements of a fixed site. The gantry and table must be mounted on a solid concrete floor. Any other floor type installations must be designed by the customer's structural engineer and meet all GE Healthcare's specifications listed in this manual.

Refer to the *Structural and Mounting Requirements* in this manual.

Upgrade Installations

Upgrade installations occur after the installation of another system. A change in the customer's needs requires the installation of additional equipment at the same site. For example, adding a PET system to an existing CT system.

To proceed with an upgrade installation, the customer's room size must be large enough to accommodate the new product without violating the regulatory and service requirements of the new product. When planning for an upgrade installation, siting requirements of the new equipment may exceed those of your existing system. Requirements needing additional consideration include:

- Floor thickness
- Room shielding
- Additional electrical capacity
- Increased cooling capacity
- Scan room shielding requirements

The final site design must include a room layout showing the equipment room with the recommended room size dimensions. All upgrade installations must meet all service and regulatory requirements detailed in the manual.

Quick Installations

Quick Installations involve sites requiring minimum room improvements. These installations typically consist of a weekend de-installation and room preparation completion, with a next business day delivery and installation.

Requirements: A site must meet a number of requirements to qualify for a Quick Installation, including: electrical, structural, and HVAC requirements outlined in this manual. Also, the suite must meet all regulatory and minimum size requirements, as well as, the scan room shielding requirements. The facility must accommodate delivery and meet all delivery requirements. Consult this manual for details of the requirements and your PMI for information about any additional requirements your installation must meet.

Restrictions: Quick Installations require a new room print that accurately reflects the rooms targeted for upgrade. You **CANNOT** re-use existing floor anchors. Check with your PMI regarding floor anchor re-use. New floor anchors must be a minimum of 102 mm (4 in) from any existing floor penetrations. Rooms not meeting the minimum requirements for the final product must undergo an upgrade/enlargement prior to the installation.

Two-Step (Temporary) Installations

The two-step installation is a temporary installation of one system in a site, with the intention of upgrading the site to another system in a near future date. All two-step installations must comply with ALL siting requirements necessary for the upgraded or final system. This includes the recommended room size and all electrical, structural, and HVAC requirements. All System Siting Requirements apply to these types of installations. The customer is responsible for verifying compliance with all requirements. Rooms not meeting minimum requirements for the final product must undergo sufficient upgrading/enlargement.

**NOTE**

Temporary installations include all systems installed at a site for a period ranging from two weeks to six months.

Chapter 3 System Siting Requirements

3.1 System Siting Requirements

The requirements listed in this manual apply to all fixed-site customer installations, including installation within re-locatable buildings. The following requirements represent the **MINIMUM** that a site must meet before beginning **ANY** new or replacement system installation. All parties should review these requirements to ensure that the site meets all of the following:

- Service requirements
- Regulatory requirements
- Minimum structural, flooring, and vibration requirements
- Minimum HVAC requirements
- Minimum Electrical requirements
- All network requirements
- All radiation protection requirements
- All operational clearances
- All finished doors, floors, windows, ceilings, walls, and all plumbing and cabinets are installed.
- Does not have ANY continuing construction in the scan room OR neighboring suite areas.
- Conforms to the final GE Healthcare site print, which must be kept ON-SITE and must show all items intended for the finished room.



NOTE

Each site should receive a CT scanner quick start kit from the PMI. Use the Pre-Installation Checklist in this manual to confirm that the site meets all of the requirements listed above. GE Healthcare recommends completing all work to meet these requirements PRIOR to starting installation.

GE HEALTHCARE RESPONSIBILITY The Project Manager (herein referred to as PM or PMI) assists the purchaser in meeting all system siting requirements.

The PMI also performs the following pre-installation delivery tasks:

- Determines the delivery type: ground, dock.
- Determines if the delivery requires tilt dollies or riggers; orders dollies and lifting crates, as needed.
- Determines if the delivery requires the use of floor protection.
- Determines if the ground delivery requires the use of a forklift, and informs GE Transportation of the need for a forklift.

Site Review with Customer A site-ready visit should occur prior to the delivery date. This visit verifies that the site meets all system siting requirements and confirms that installation can proceed. During the site-ready visit, a GE representative confirms that the site meets all of the required site-ready conditions including floor levelness, and delivery route readiness. Lifting options and construction site packaging must be ordered prior to delivery and cannot be added on-site.

CUSTOMER RESPONSIBILITY Listed below is the breakdown of the customer tasks crucial for ensuring proper site preparation, regardless of whether planning for a replacement system at an existing site, or designing a new scan room for a first time.

Installation cannot proceed until verification of site-readiness occurs. A site is ready **ONLY** when it meets ALL delivery, regulatory, system, network, radiation protection, and operational requirements, as well as, requirements for any options. The purchaser is responsible for completing all work necessary to install the system, and includes:

- Completion of all structural items (recommended before installation begins.)
- PMI verification that ALL items on the Pre-Installation Checklist are completed.
- Review and preparation of all site-ready items.

To ensure timely delivery and installation, GE Healthcare recommends that the customer complete all necessary work and schedule a site-ready visit prior to the delivery date. To confirm that the site meets all requirements, you may need to employ these and other contractors: Structural Engineer and/or Architect, HVAC Contractor, Electrical Contractor, Qualified Radiological Health Physicist, Cleaning Services.

NOTICE

An improperly prepared site—one that is in a state of construction—can result in a delayed installation date and/or damage to the system.

Regulatory Requirements

The room must meet all regulatory clearance requirements.

The room must meet all minimum size requirements.

The site print is on-site, reflects actual room size and layout, and has received final approval.

No grounded walls are found in regulatory clearance areas.

The room meets all local codes.

Electrical

Install the correct size junction boxes with covers at locations shown in the installation plan.

Install appropriate conduits and duct work for system cables. If the suite houses additional components, determine the necessary considerations and complete the connections.

Install a power supply of correct voltage output and adequate kVA rating.

Install local disconnects, including proper over-current protection. This includes the A1 main disconnect with Lock-out and Tag-out (LOTO) installation.

Structural

Install “steelwork” or other suitable support work for mounting equipment from walls or ceilings.

Review structural requirements such as floor vibration, floor levelness, floor thickness, and any seismic considerations.

Complete all suite and room renovations and modifications prior to delivery.

Dust and Air Quality

Ensure that the scan suite area is free of all dust, and not subject to ANY ongoing construction, including the installation of cabinets, hanging doors, and ceiling tiles.

NOTICE

SERVICE NOTICE: Because the CT scanner's air intake is near the bottom of the gantry and draws in air through a filter in the gantry heater assembly, fine dust—like that created during room construction or renovation— can clog this and other filters found on the DAS, tube, and operator console. If this occurs, dust may become deposited throughout the gantry, table, operator console and PDU electronics. Once inside the unit, removal becomes impossible, resulting in potential **DAMAGE** to electronic components and **EARLY SYSTEM FAILURE**. Consequently, the scanner is the last item installed in the scan suite area.

TYPES OF DUST TO AVOID Ensure that **NO** construction occurs in or immediately around the scan suite area that results in:

- concrete dust
- drywall dust
- ceiling tile dust
- wood sawdust or shavings
- dust tracked into the CT suite from adjoining rooms

Failure to take appropriate precautions to protect the system against these types of dust may result in **DAMAGE** to the system and early **SYSTEM FAILURE**.

Environmental Influences Consider

CT systems are designed with commercial components that are sensitive to air contaminants like sulfide, chloride and nitrates. It is the responsibility of the purchaser to ensure that the levels of these contaminants are low (Class1). See IEC60654-4 for air quality guidelines.

Finished Floor Requirements

Installation requires a finish floor in the scan and control rooms. The floor surface in the scan room directly under the gantry and table must be level. The floor flatness tolerance of the floor surface that the gantry and table will rest on is 6 mm (1/4 in) over a 3000 mm (118.0) distance. Shims should not be used to compensate for a floor that does not meet this requirement. Eight or more floor covering openings that are 101.6 mm (4 in) in diameter are made to ensure the table and gantry rest on a solid surface. These floor penetrations can be sealed if required. These requirements apply to all installation types.

Finished Floor Exception 1 For sites replacing their scan room floor covering after the table and gantry are installed, the floor can be clean-finished with dust free concrete. The finish floor in the scan room requires no dust-producing operations when applying final floor covering.

Finished Floor Exception 2 Facilities under new construction that have a finished radiology area with a single controlled-access and dust abatement barrier, can have a finished concrete floor in the scan room. The finished concrete floor in the scan room requires no dust-producing operations when applying final floor covering.

Finished Walls Requirements

Finished walls inside the scan and control rooms must be painted at the time of installation. This requirement applies to all installation types. A finished walls exception is made for new construction and upgraded facilities. A primer coat of paint is acceptable for equipment installation. However, the final coat of paint must be applied using a brush of some type (roller, or bristle). The final coat of paint cannot be applied using a spray method.

Radiation Protection

A qualified radiological health physicist should verify that the scan room's radiation shielding provides adequate radiation protection for the planned system.

Environmental

Review HVAC requirements, including system environmental controls and patient comfort needs. Make sure the site provides an HVAC system capable of maintaining the recommended temperature and humidity specifications at the time of installation.

Options

Confirm that all customer installation options are reviewed and final locations determined.

All GE supplied installation options are reviewed and final locations determined.

The laser camera should be on site at the time of system installation.

Clearances

Review operational clearances to verify whether daily use items fit (e.g. beds, carts).

Consider clearances for emergency medical equipment.

Ensure that all storage cabinets and sinks appear on the site print in their proper locations.

Confirm that adequate space exists in the scan suite for delivery and installation of all replacement parts following installation of the system.

Network

Ensure that network communication is in place and active.

Chemical Contamination

Never install wet film processors in the same room as the scanner, as this may result in possible contamination of scanner components. Chemicals utilized by such processors can contribute to increased equipment failures and downtime, and decreased reliability.

When siting this equipment, consider the effects that contact with these chemicals and the resulting fumes might have on human subjects in proximity to them. In addition, film processor equipment installation must meet all manufacturer requirements (e.g. ventilation specifications) as well as all applicable local, state, and national codes.

Delivery

Determine room dimensions and verify that doorways adequately accommodate the system.

Verify the existence of an accessible dust-free non-construction zone route to the scan suite that accommodates delivery.

Identify elevators, doorways and hallways that can accommodate delivery.

Provide floor protection, if needed.

Request rigging, if needed.

Page intentionally left blank

Chapter 4 Regulatory Requirements

4.1 Regulatory Requirements

Regulatory Terms and Definitions

CLEARANCES Clearances are the clear space or distance between or around objects and equipment, governed by all applicable safety, service and regulatory requirements and representing the lowest margin of freedom permissible for equipment siting.

DIMENSIONS The length, width, depth and height of equipment.

EGRESS An area of clear space to allow safe evacuation of personnel.

NOTICE

The maps and dimensions shown in this manual depict the required clearances for proper equipment operation and service only. The customer is responsible for federal, state, and local codes regarding facility egress and related facility requirements.

PRE-INSTALLATION ESCALATION Pre-installation escalation is the process used to consult CT Engineering, the Design Center, or Environmental Health and Safety (EHS) to resolve pre-installation issues related to siting concerns and requirements.

GROUNDING WALL A grounded wall is any wall with electrical conductivity to earth. Conductive materials generally found in walls include masonry, concrete, and tile. These should also be treated as grounded, additional elements commonly found in walls, including but limited to the following:

- medical gas ports and plates
- metal doors and window frames
- water sources and metallic sink structures
- metallic wall mounted cabinets
- A1 main disconnect panel
- Equipment Emergency Off panels
- industrial equipment (such as air conditioners and vents)
- expansion joints
- surface raceway
- exposed wall conduits
- floor outlet boxes
- floor HVAC boxes
- floor medical gas

Common wall components **NOT** constituting grounded elements include:

- standard wall outlet

- light switches
- telephones
- communication wall jacks
- ceiling tile grids

HEAD CLEARANCE Head clearance represents the height dimension of the work-space, measured from the floor at the front edge of the equipment to the ceiling or any overhead obstructions. It requires a minimum of 1981 mm (78 in) of the height of the equipment, whichever is greater.

MINIMUM Minimum indicates the lowest limit permitted by law or other authority.

SERVICE ACCESS WIDTH Service access width refers to the width of the working space in front of the equipment, and requires a minimum of 762 mm (30 in) or the width of the equipment, whichever is greater.

WORK-SPACE The work-space represents a three dimensional box of space required for safe inspection or service of energized equipment. It consists of depth, width, and height, with the depth dimension measured perpendicular to the direction of access. US regulation requires a minimum depth of 914 mm (36 in). Additional conditions can increase the minimum requirement. For example, GE Healthcare defines work-space as the envelope of the component superstructure, measured for the NGPDU with the front panel removed, and measured for the gantry and table with the extended covers removed.

4.2 Regulatory Clearances

Refer to [Appendix A Regulatory Clearances for US on page 161](#) for United States (US) installations.

Chapter 5 Service Clearance Requirements

5.1 Service Clearance Requirements

The service envelopes defined in [Figure 5-1 Minimum Service Clearances on page 30](#) provide enough space to safely allow CT system service to be performed. Refer to the appendix for alternate cover removal options and room configurations.

System servicing requires sufficient space to remove the covers from the system. It also requires one service engineer to be able to accomplish all service component replacement tasks without the need for special tools or equipment. ALL room layouts must provide service space and access around the table to the gantry right side. This is needed for replacement procedures which require components that ship in large boxes, such as the tube, detector and HV tank.

Table 5-1 CT Components in Illustration

Item	Description
A	Gantry with covers installed
B	Table cradle footprint, coverage as extended in both directions
C	Front gantry cover removed with dolly
D	Back gantry cover removed with dolly

Figure 5-1 Minimum Service Clearances

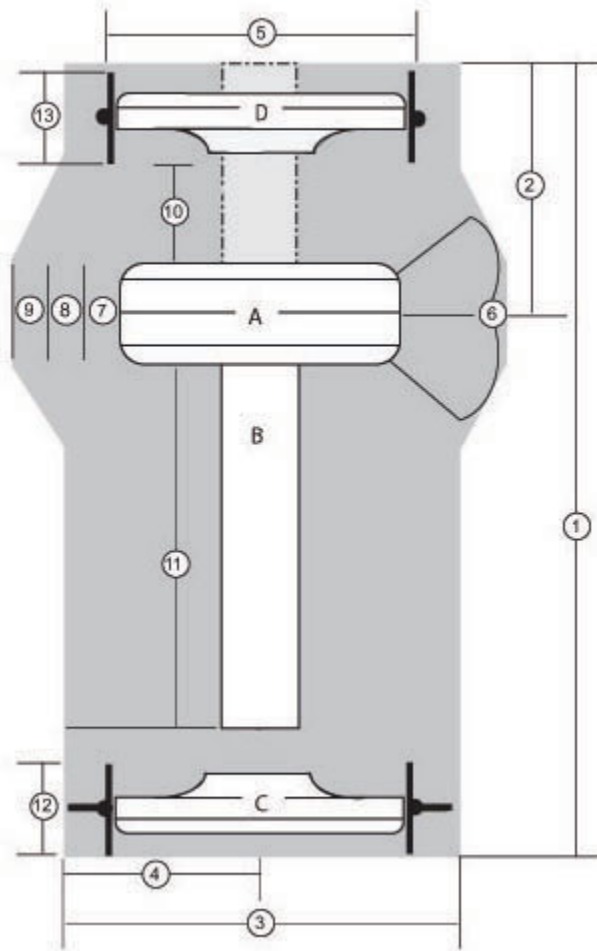

NOTE

When calculating service clearances refer to this table, [Table 5-2 Minimum Clearances Reference Definitions on page 30](#), for all service clearance needs.

Table 5-2 Minimum Clearances Reference Definitions

Item	Dimension
1 VT1700 VT2000	5842 mm (230 in) 6452 mm (254 in) (travel distance of table)
2 VT1700 VT2000	2108 mm (83 in) (cover with dolly)
3	3200 mm (126 in)
4	1600 mm (63 in)
5	2362 mm (93 in)
6	914 mm (36 in) minimum
7	356 mm (14 in)

Table 5-2 Minimum Clearances Reference Definitions (Table continued)

Item	Dimension
8	711 mm (28 in)
9	914 mm (36 in)
10	914 mm (36 in)
11	2794 mm (110 in)
12	686 mm (27 in)
13	495 mm (19.5 in)

Gantry Service Clearance

Specifications for Boom Assembly clearance arc are defined in [Figure 5-2 Boom Assembly Clearance](#) on page 31. The boom assembly is used during tube and detector replacement. The minimum ceiling height within the clearance radius is 2286 mm (90 in).

Figure 5-2 Boom Assembly Clearance

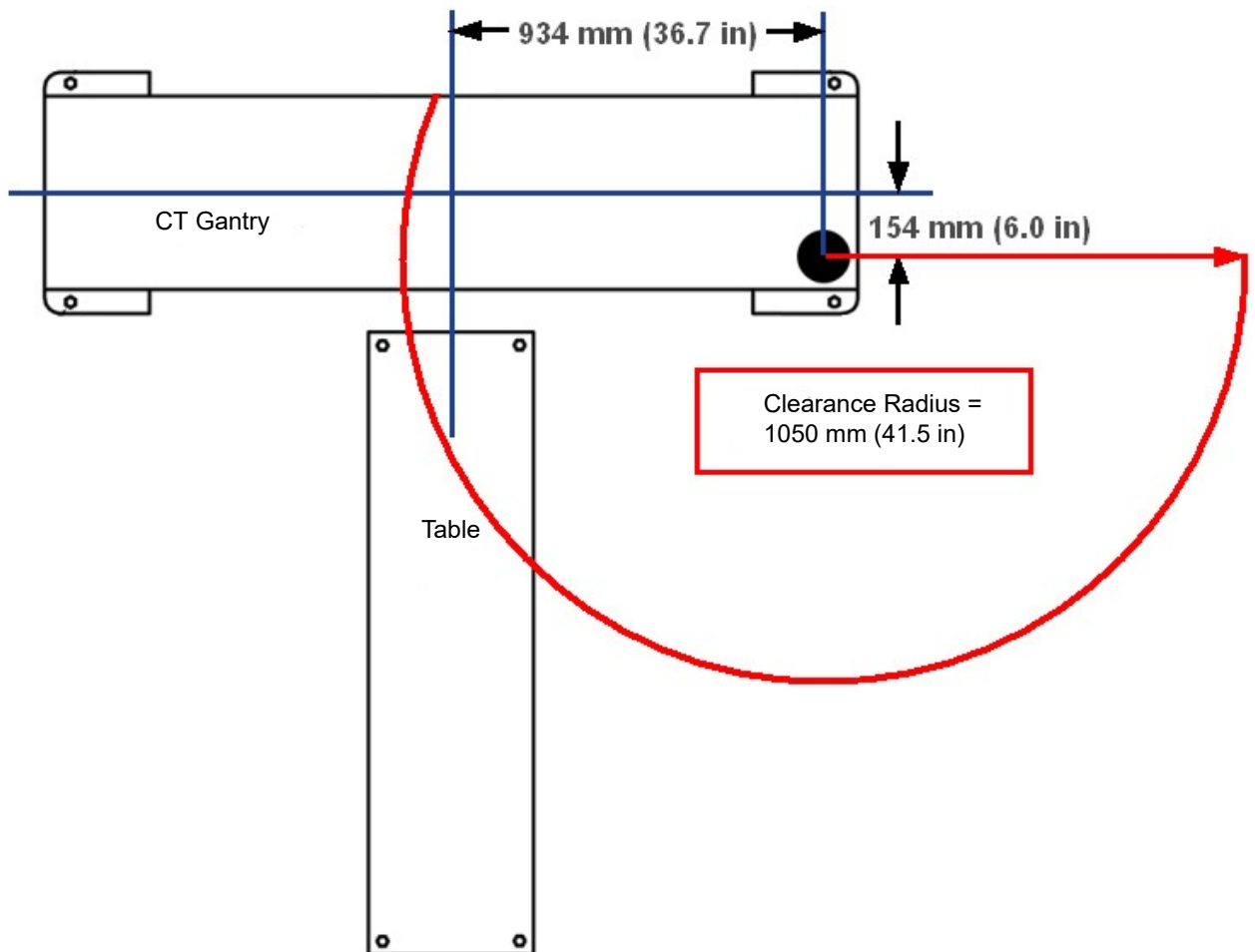

Cover Removal



NOTE

The cover dollies are designed for use with one field engineer. If two field engineers are present the covers can be placed on the dollies and moved outside the scan room to allow for minimum service requirement space.

Gantry front cover removal requires the use of the tilting cover dollies and a minimum clearance space of 3200 mm (126 in) to maneuver the cover as shown in [Figure 5-1 Minimum Service Clearances on page 30](#). The dollies allow the service engineer to separate the cover from the gantry, tilt it 90 degrees, roll it to the foot end of the table, and then tilt it an additional 90 degrees, so that it is upside-down relative to its normal system-mounted condition. After removal, the service engineer must then move the gantry front cover to a position that satisfies the minimum regulatory clearances.

The gantry rear cover, with service dollies installed, required a clearance width of 2388 mm (94 in) and depth of 914 mm (36 in) for removal, as shown in *Typical Room Layout* section of this manual. Sufficient space to allow the service engineer to move the cover either straight back or to one side of the table to satisfy the minimum service clearances, shown above, must be maintained. The rear cover with dollies cannot extend past the allowable clearance space within the room. If the system is not sited straight (positioned diagonally) in the room, full service space is still required. The PMI and customer should discuss this consideration and make the necessary provisions.

Refer to the appendix for alternate cover removal options and room configurations.

The scan room must offer sufficient space to allow adequate egress during service operations that require both front and rear cover removal. If the customer and PMI have any concern that site will not provide adequate space for egress under these conditions, they should discuss these requirements and make the necessary provisions to accommodate this event.

After cover removal, a single service engineer can safely perform service on the system or table. Ensure sufficient clear space to maintain egress clearances with the table/cradle covers or gantry covers removed.

A tube change box is 1524 mm (Length) x 737 mm (Width) x 640 mm (Height) (60 x 29 x 25 in.) with the handles extended. The box rolls like a wheelbarrow and must have access to the right side of the gantry. It is the PMI's responsibility to demonstrate that the tube change box can be positioned in the tube change area next to the gantry and that the front and rear covers can be removed.

Power Distribution Unit (NGPDU)

When positioning the Power Distribution Unit, consider regulatory compliance as defined in this manual under *Regulatory Clearances*.

Console

The operator console does not present an exposed live parts hazard. However, the site shall maintain a working space at all times with a minimum depth of 1219 mm (48 in) extending the full width of the operator console for service activity. The console is on wheels. As some service activity requires access to the rear of the console, be sure to maintain sufficient space for moving the console to allow rear service access. See section on *Typical Room Layout*.

Service Equipment Storage

A storage cabinet or defined storage space is required to store service equipment purchased with the system. If the optional storage cabinet has not been ordered with the system (See Pre-Install Checklist— Site Planning Requirements) adequate space must be provided to store this equipment. GE

Healthcare recommends that the storage of the service equipment be located as close as possible to the scan suite.

The minimum dimensions for a storage space or storage cabinet is nominally: 610.0 mm (24 in) deep by 914.0 (36.0 in) Wide by 1067.0 mm (42.0 in) high.

**NOTE**

The service equipment is the property of the customer and shall NOT be removed from the site and/or stored off-site by GE Healthcare personnel.

Table 5-3 Equipment stored in the storage cabinet

Item	Size	Weight metric (US)
QA Phantom (water filled)	20 X 15 cm (7.9 X 5.9 in)	5.5 kg (12 lb)
35CM Phantom	35 X 7 cm (13.8 X 2.8 in)	8.2 kg (18 lb)
Phantom Holder	25 X 25 cm (9.8 X 9.8 in)	3.6 kg (8 lb)
FE Box (purple)	30 X 38 X 30 cm (11.8 X 15 X 11.8 in)	6.8 kg (15 lb)
Rear cover dollies	158 X 82 cm (62.2 X 32.3 in)	11.4 kg (25 lb)
Front cover dollies	85 X 20 cm <i>and</i> 85 X 15 cm (33.5 X 7.9 in) <i>and</i> (33.5 X 5.9 in)	15.9 kg (35 lb)
Install Support Kit (box)	30 X 30 X 38 cm (11.8 X 11.8 X 15 in)	9.1 kg (20 lb)
3 Piece Tube Hoist Assembly	77 X 8 cm <i>and</i> 38 X 15 cm (30.3 X 3.1 in) <i>and</i> (15 X 5.9 in)	9.1 kg (20 lb)
Balance weight kit		33 kg 73 lb

Page intentionally left blank

Chapter 6 Room Sizes

6.1 Room Sizes

Room Dimensions

Table 6-1 Suggested Room Size Dimensions

System Configuration	Suggested Room Size (Note 1)	Minimum Room Size (Note 2)
System with VT 1700 Table	6710 X 4270 mm (22' 0" X 14' 0")	6100 X 3560 mm (20' 0" X 11' 8")
System with VT 2000 Table	7320 X 4270 mm (24' 0" X 14' 0")	6710 X 3560 mm (22' 0" X 11' 8")
Note 1: All service/regulatory requirements apply.		
Note 2: All service requirements apply, with the addition of no energized left-side service.		

Suggested Room Size The suggested room configuration offers the most flexibility for future upgrades. It provides both ample work-space and space to add millwork and still meet all regulatory requirements. When local regulations require a sink in the scan room, this room size also provides sufficient space for a sink. This room size accommodates the needs of larger hospitals and medical teaching facilities, where patients may require transportation to the scan area in beds, gurneys, and larger wheelchairs and where they may require the assistance of larger medical care teams. Likewise, this room offers adequate access for crash carts and other emergency medical equipment on both sides of the table. The suggested size supports all service activities, including tube change, and accommodates all future two-step installations.

Minimum Room Size The minimum room configuration represents the smallest functionally acceptable space for this product and represents the type of room often found at doctor's offices and smaller clinics and outpatient facilities.



NOTE

The dimensions shown for the minimum room size assume a room configuration in which the front and rear gantry covers are removed and stored straight back. See *Service Clearance Requirements*. Refer to the appendix section for alternate cover removal options and room configurations.

Due to its limited size, and to functional and regulatory requirements, the minimum room usually provides only LIMITED work-space, and leaves NO space to add in-room millwork and sinks and still meet the necessary regulatory and service requirements. This room can accommodate the transportation of patients into the scan area using wheelchairs, and provides access for crash carts and other emergency medical equipment on only one side of the table. Sites considering a minimum room size may not have been designed with the structural requirements necessary to support the system and consequently may require upgrading prior to installation.

Customer considering a minimum room size should discuss their work-space requirements and future upgrade plans with their PMI, as the size and layout of these rooms often eliminates them from any future upgrade considerations and offers NO compatibility with future two-step installations.

If using the square meters (square footage) to determine regulatory compliance, please note that the front and rear cover clearances are wider than the regulatory clearance along the table length, and that the cover park position is behind the table in the home position.

**NOTE**

Site must provide sufficient space to allow the removal of the rear cover, which is on wheels, from behind the gantry during service operations.

CAUTION

OPERATIONAL CAUTION: IN A MINIMUM ROOM LAYOUT THE CUSTOMER SHOULD CONSIDER WORKFLOW, CUSTOMER ACCESS FOR PATIENT CARE, AND CRITICAL-CARE OPERATIONS SPACE REQUIREMENTS.

Additionally, this room provides only limited equipment access on the gantry left side when loading patients.

And also when positioning patient equipment in the room between the gantry and the wall.

Suggested Room Layouts

The illustrations below show the recommended and typical room layouts, both with and without in-room cabinets. You need to know the locations for medical gas, surface duct work, or other items that make a grounded wall.

**NOTE**

Your room layout may meet the recommended or typical room requirements but appear different than what is shown here. Your salesperson can provide a detailed room layout for your site.

Figure 6-1 Room Layout with Cabinets

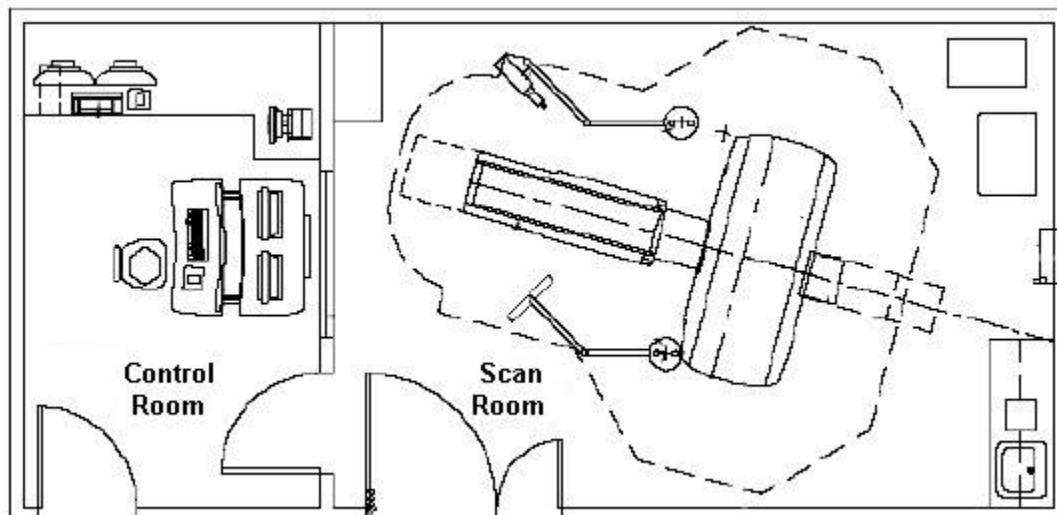
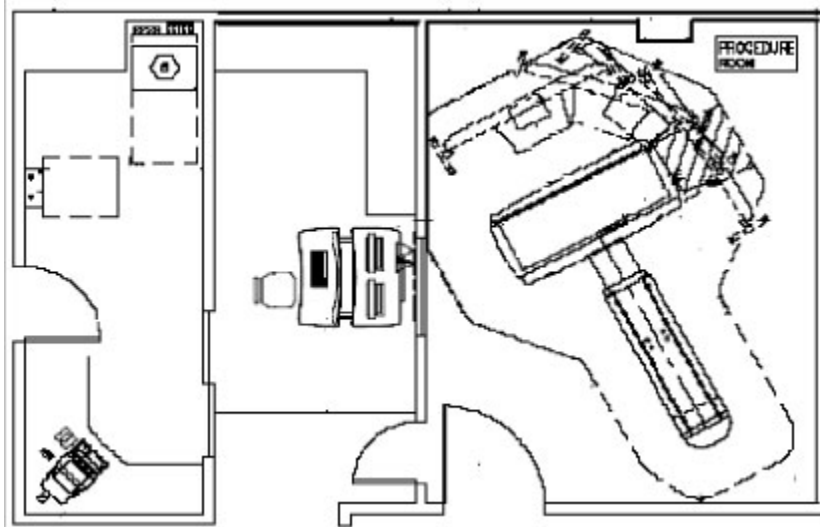

Figure 6-2 Room Layout without Cabinets**NOTE**

The room in [Figure 6-2 Room Layout without Cabinets on page 37](#) without Cabinets shows ample space for the removal of both front and rear covers.

The enclosure (Patient Touch) Leakage Envelope, as detailed in [Figure 6-3 Leakage Envelope on page 38](#), defines a zone in the Scan Room only, where the enclosure leakage must be tested. Areas that fall outside of this envelope DO NOT need to be tested. The intent of this graphic is to provide the PM with a view of potential electrical devices, plumbing fixtures, hospital gas outlets, and metal surfaces that may fall within this scan room envelope, which may require additional grounding prior to customer turnover. [Height of envelope from floor-to-ceiling: IEC-2 = 2286.0 mm (7.5 Ft.), IEC-3 = 1829.0 mm (6.0 Ft.). UL60601-1 (2.12.20 DV Addition) and GE Healthcare requirement.]

**NOTE**

The enclosure leakage envelope has nothing to do with Regulatory Work Space Clearance or Safe Egress requirements for Service Personnel (NFPA 70E).

Figure 6-3 Leakage Envelope

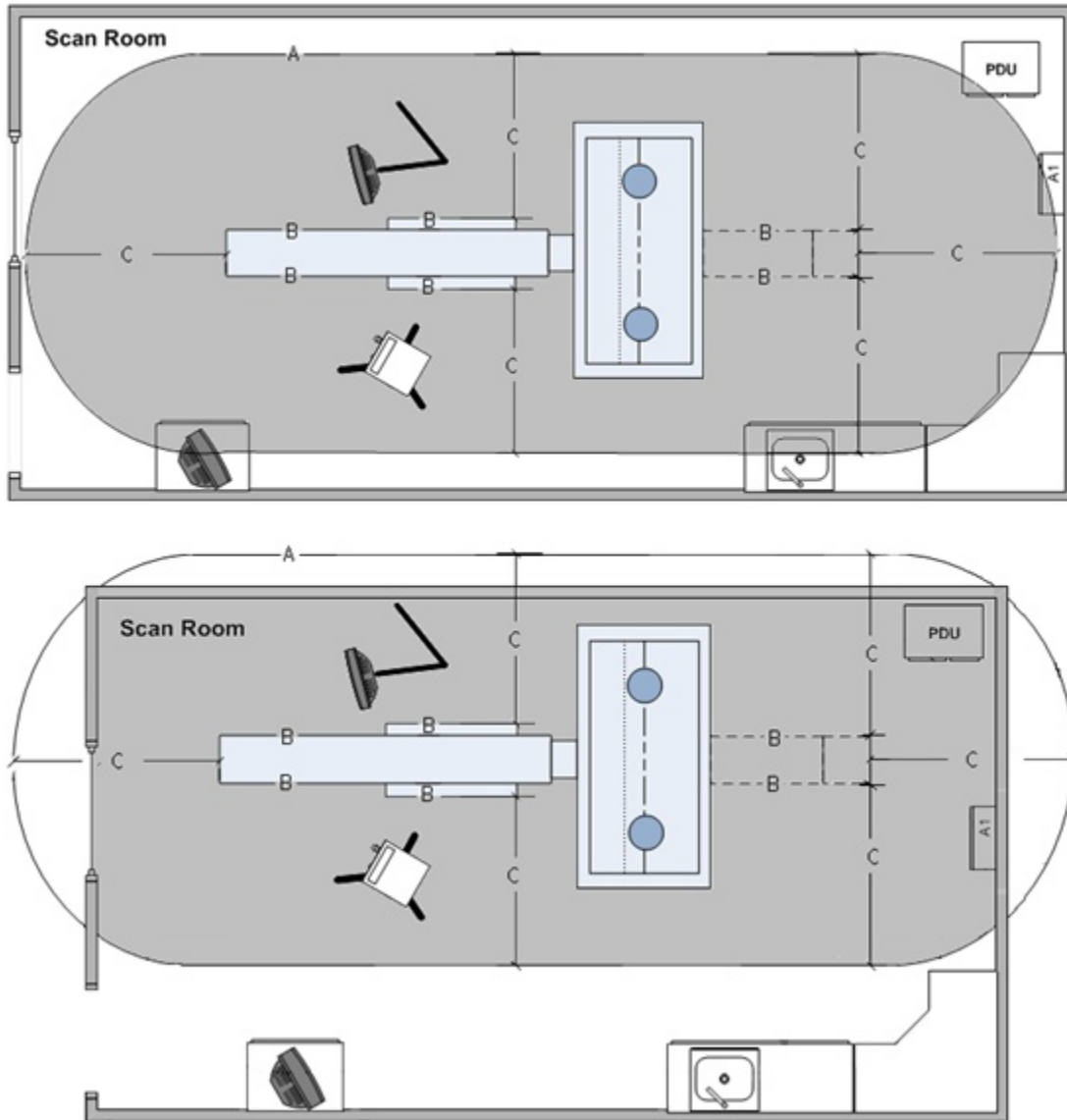

A = Patient Care Perimeter Envelope, B = Equipment Perimeter, C = Width and Height		
Reference	Dimension [C]	
	Width	Height
IEC Ed 2	1829.0 mm (6.0 Ft.)	2286.0 mm (7.5 Ft.)
IEC Ed 3	1829.0 mm (6.0 Ft.)	1829.0 mm (6.0 Ft.)

Minimum Room Layout



NOTE

If the room size does not meet the suggested room layouts, but meet the minimum room layouts, you don't have to submit the concession

The minimum room layout shown in [Figure 6-4 Minimum Room Size - Layout A on page 39](#) **Room Layout A** provides less than 914 mm (35 in) - but greater than 711 mm (28 in) of space, measured from covers to left-side wall. It offers sufficient service, egress and work-space around the gantry.

**NOTE**

The intent of minimum room size drawings is to provide a minimum space requirement needed to install and service the system. Always consult local regulatory agencies which may impact final siting of the room.

Figure 6-4 Minimum Room Size - Layout A

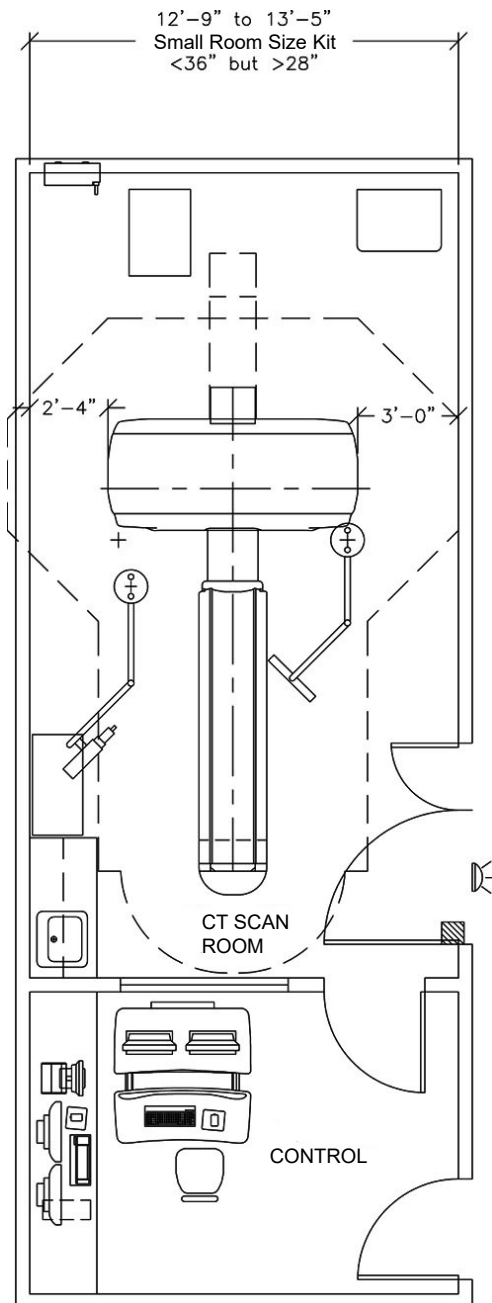

The minimum room layout shown in [Figure 6-5 Minimum Room Size - Layout B on page 40](#) **Room Layout B** provides less than 711 mm (28 in) but greater than 256 mm (14 in) of space on the gantry left side, measured from covers to left-side wall, compromising service, egress, and work-space on the gantry's left side.

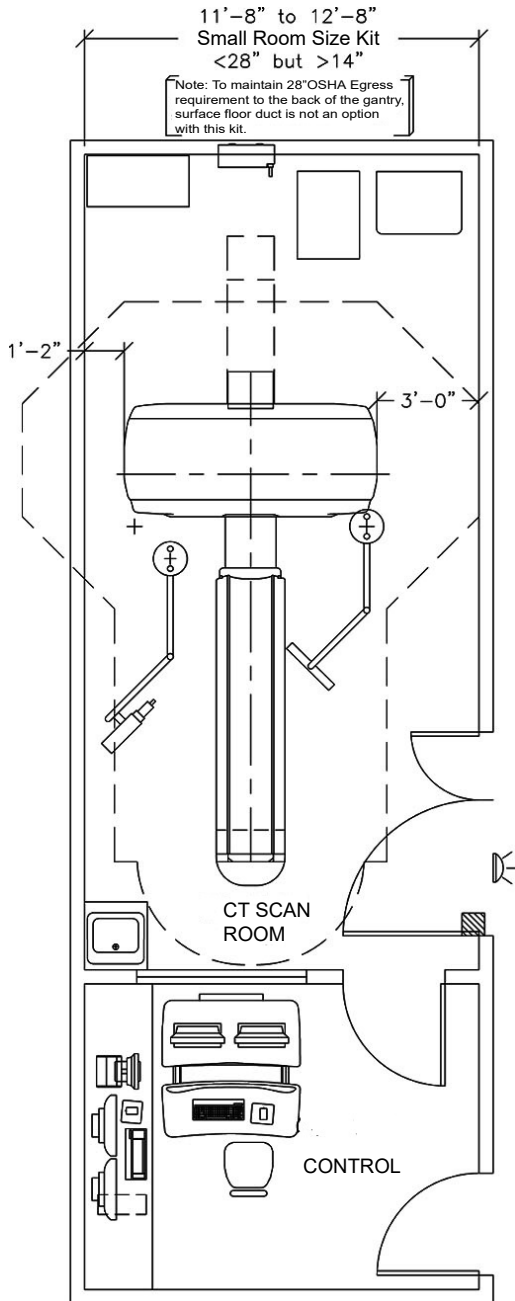
Figure 6-5 Minimum Room Size - Layout B

Control Room Considerations

The control room must provide an operating environment suitable for the operator console electronics and the operator's working comfort. The operator console must remain in the same configuration as shipped. Do not dismantle the console, or remove or rearrange its components. Do not position the monitor desktop or user desktop components on a counter-top or mount the operator console cabinet remotely.

Cable lengths must remain as shipped (cables cannot be cut or extended to mount the monitor on the customer's counter).

As the console requires adequate venting, maintain 152 mm (6 in) of clear, unobstructed space on all sides of the console to allow the four fans located on the rear of the console to exhaust air to both the

left and right. Provide a suitable work area within reach of the operator console for the placement of the injector control. Injector controls differ in dimensions depending on the brand selected.

A PACS, workstation, image printer, or filming device may appear in the operator console control room area. These devices or other components, though having a direct link to the operator console via network or Ethernet cable, shall NOT receive power from the CT operator console. If you are using additional devices or components, consider additional room power and network connections when reviewing the operator console work-space.

Figure 6-6 Typical Control Room Layout

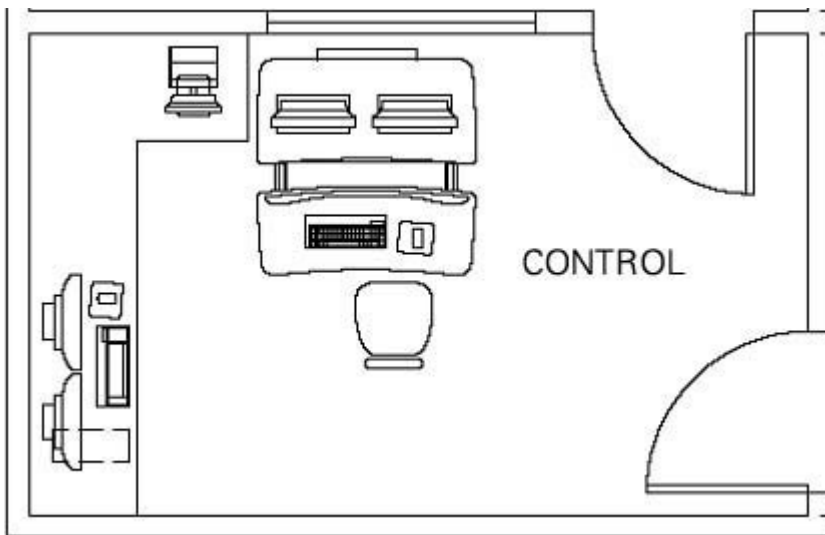

Console Long Cable Option

Console cabinet can be placed approximately 3 meters away from LCD monitor, GSCB and keyboard by using Console Long Cable Option.

Refer to Console Long Cable Option Installation Manual (Direction 5456816-1EN) for the details.

Notice for Console

NOTICE

When install the Console Cabinet in the scan room, do not place it within the patient environment. Refer to [Patient Environment on page 41](#) for the details.

Patient Environment

The patient environment is defined as the following picture.

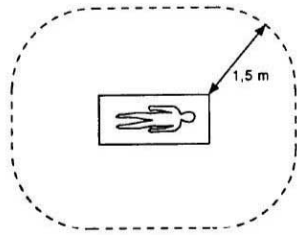
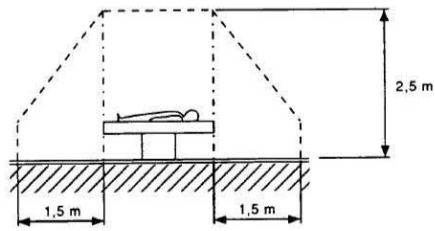

IEC 2513/2000

Only Scanning Gantry, Patient Table components and the following options can be placed in this area.

- Advantage 4D
- In room monitor
- SmartStep
- Extream Injector
- AVIMOS Camera

Chapter 7 System Component Dimensions

7.1 System Component Dimensions

Minimum Operating Clearances

Ceiling Pedestal Mount Installation The distance from the floor to the lowest point of the ceiling pedestal mount for the injector or monitor CANNOT measure LESS than 2134 mm (84 in). Refer to the installation guides of those components for the length of the mounting post.



NOTE

The down post or ceiling mounted pedestal used to mount injectors, remote monitors or other devices shall not be installed within the tube crane area. See Gantry Service Clearance.

NOTICE

Failure to maintain a distance of at least 2134 mm (84 in) from the floor to the lowest point of the injector or monitor ceiling pedestal mount may pose a safety hazard. For installations with a finished ceiling height that is less than suggested, consideration should be given to utilizing floor mounted components, or attaching the mounting plate in the overhead (for example, above dropped ceiling tiles).

Injector Control Installation Minimum dimensions and clearances include the following requirements for the injector control:

- Provision of suitable work area for placement of the injector control, within reach of the operator console.
- Wall mounted, ceiling mounted, and pedestal units require routing of cables from the gantry area to the operator console area. The supplied cable measures 15.2 m (50 ft).
- Injectors require an AC power source that is powered from the console. The IEC power cord is supplied with the injector.
- Available mounts come in several different lengths and configurations. Refer to the injector documentation for detailed installation instructions.



NOTE

The down post or ceiling mounted pedestal used to mount injectors, remote monitors or other devices shall not be installed within the tube crane area. See Gantry Service Clearance.



NOTE

For GOC6 and GOC6.5 console systems, the console requires IEC power plugs to power GE approved options. All options used with the system must be powered using the console or gantry power plugs. For systems using any NEC power plugs, options (DASM Modems, video splitters, etc.) must be plugged inside the console power strip using the IEC power plug configuration.

System Operational Clearances The clearances listed in the table below govern system operation; be sure the site maintains each of these clearances.

Table 7-1 Minimum Dimensions and Operational Clearances

System Operation	Clearance	
Optional pedestal ceiling mount	2134 mm	84 in
Lowest point on mount to finished floor:		
Finished ceiling to floor (suggested)	2743 mm	108 in
Finished ceiling to floor (minimum)	2286 mm	90 in
Table to maximum extension head end with extender from Center line	2126 mm (GT2000/GT2000x)	84 in
	1826 mm (GT1700)	72 in
Table extension head end with extender to obstruction	152 mm	6 in
Table in lowest position, with cradle at home position to Center line	3700 mm (GT2000/GT2000x)	145.7 in
	3157 mm (GT1700)	124.3 in
Back of Console to wall	152 mm	6 in
Back of PDU to wall	152 mm	6 in

Component Dimensions

Figure 7-1 System Dimensions without the cover

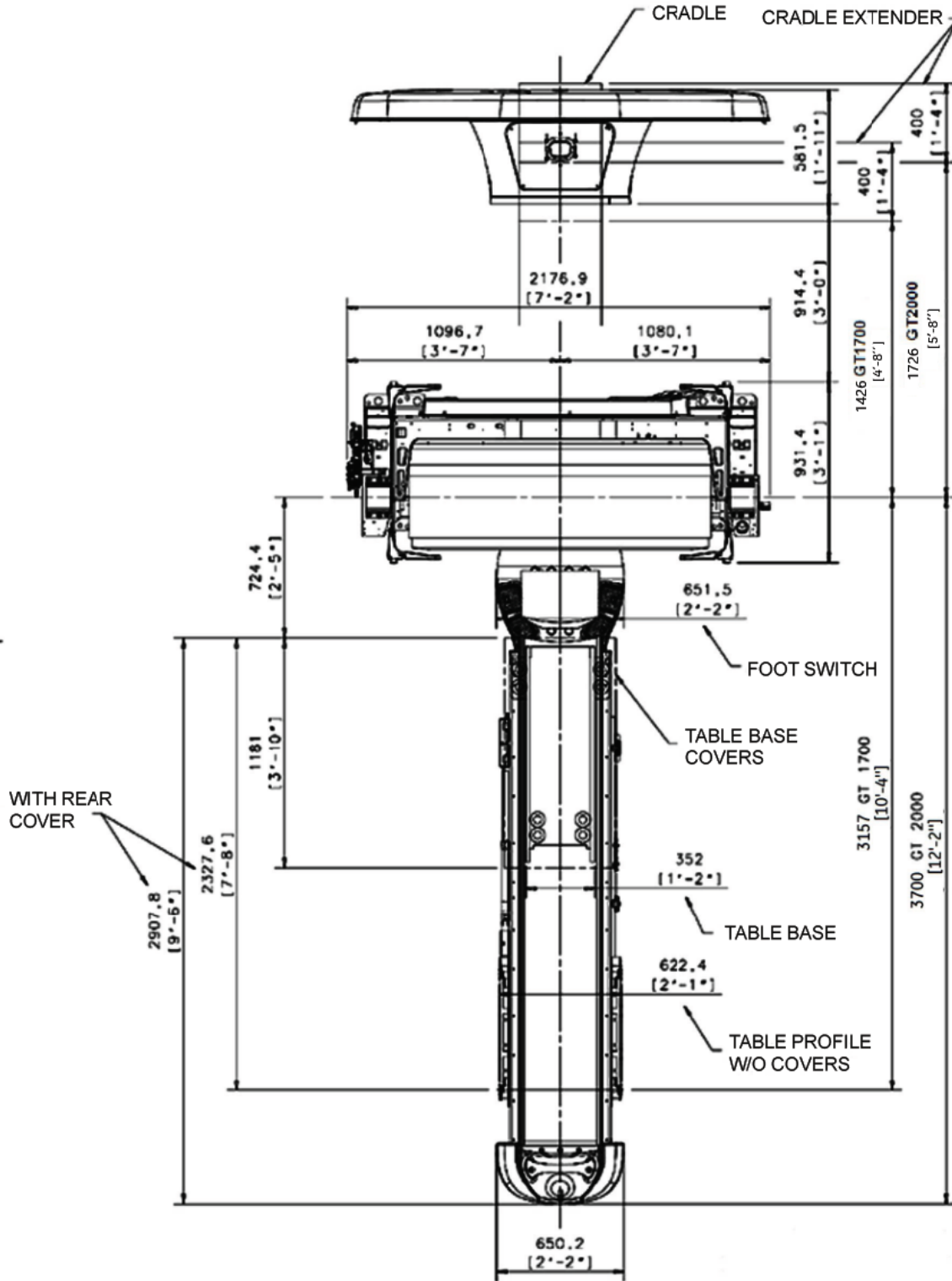

NOTE

Table is located in the farthest position of mechanical limit.



NOTE

There are two types of Gantry Front covers. The Front cover shown in [Figure 7-2 Front Cover with Service Dolly Dimensions - Discovery CT750 HD on page 46](#) is applied to Discovery CT750 HD Gantry, which is equipped with LED display panel.

The Front cover shown in [Figure 7-3 Front Cover with Service Dolly Dimensions \(Gantry with LCD Panel\) - Discovery CT and Revolution Discovery CT on page 47](#) is applied to Discover CT and Revolution Discovery CT, which are equipped with LCD display panel.

Please identify the Discovery CT750 HD from others based on the display panel.

Figure 7-2 Front Cover with Service Dolly Dimensions - Discovery CT750 HD

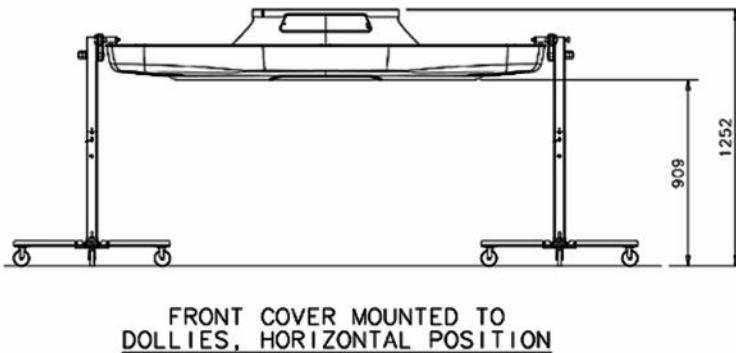
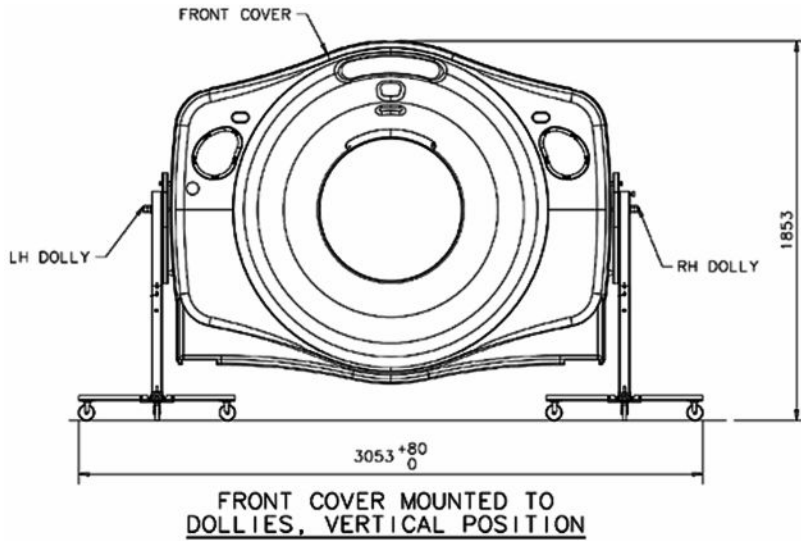

Figure 7-3 Front Cover with Service Dolly Dimensions (Gantry with LCD Panel) - Discovery CT and Revolution Discovery CT

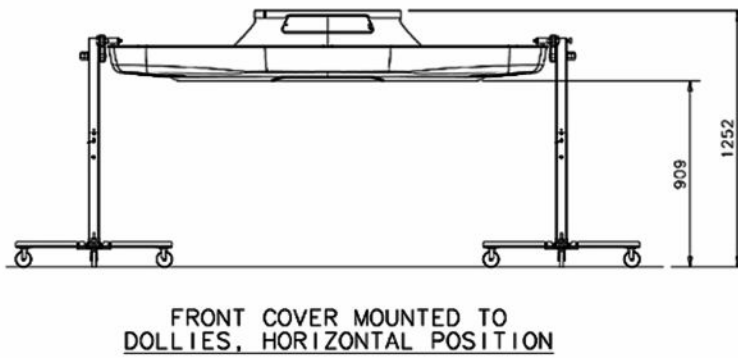
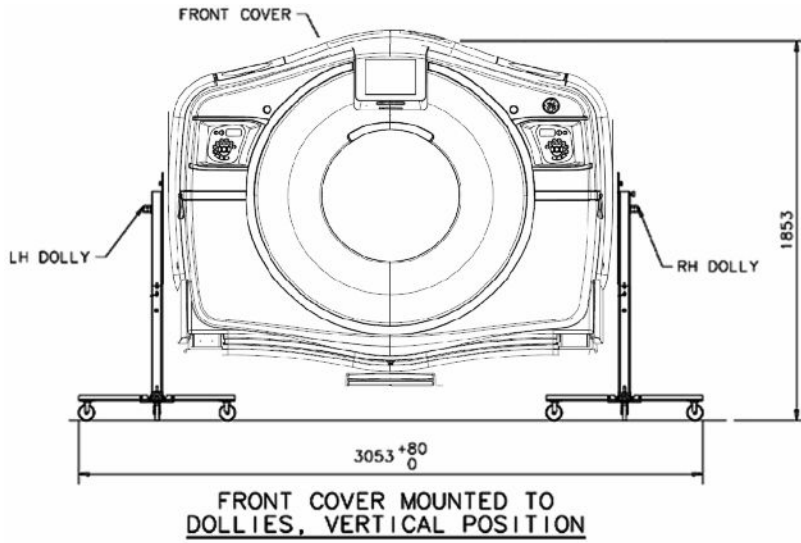

Figure 7-4 VT 1700 and VT 2000 Table and Gantry (Side View)

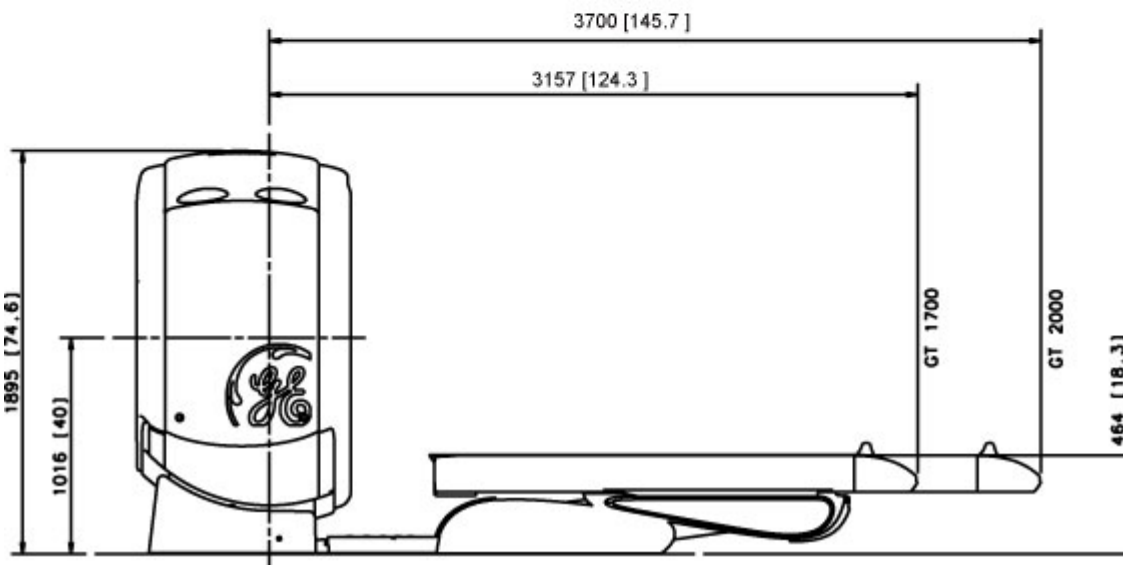
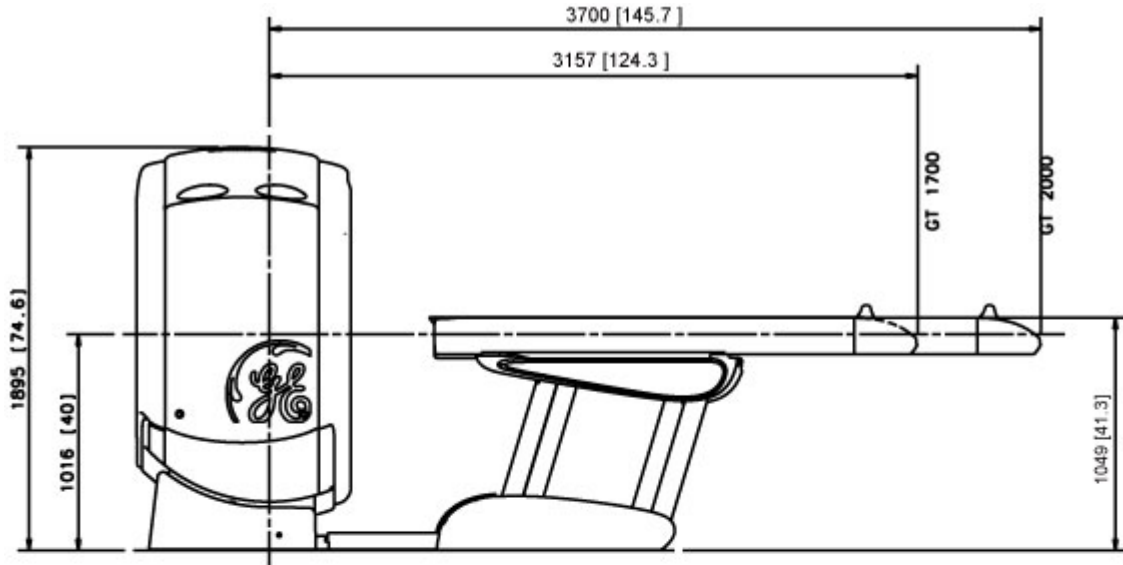

Figure 7-5 Revolution Discovery CT Gantry tilted +30° (top) and -30° (bottom) VT 1700 and VT 2000 Table Options

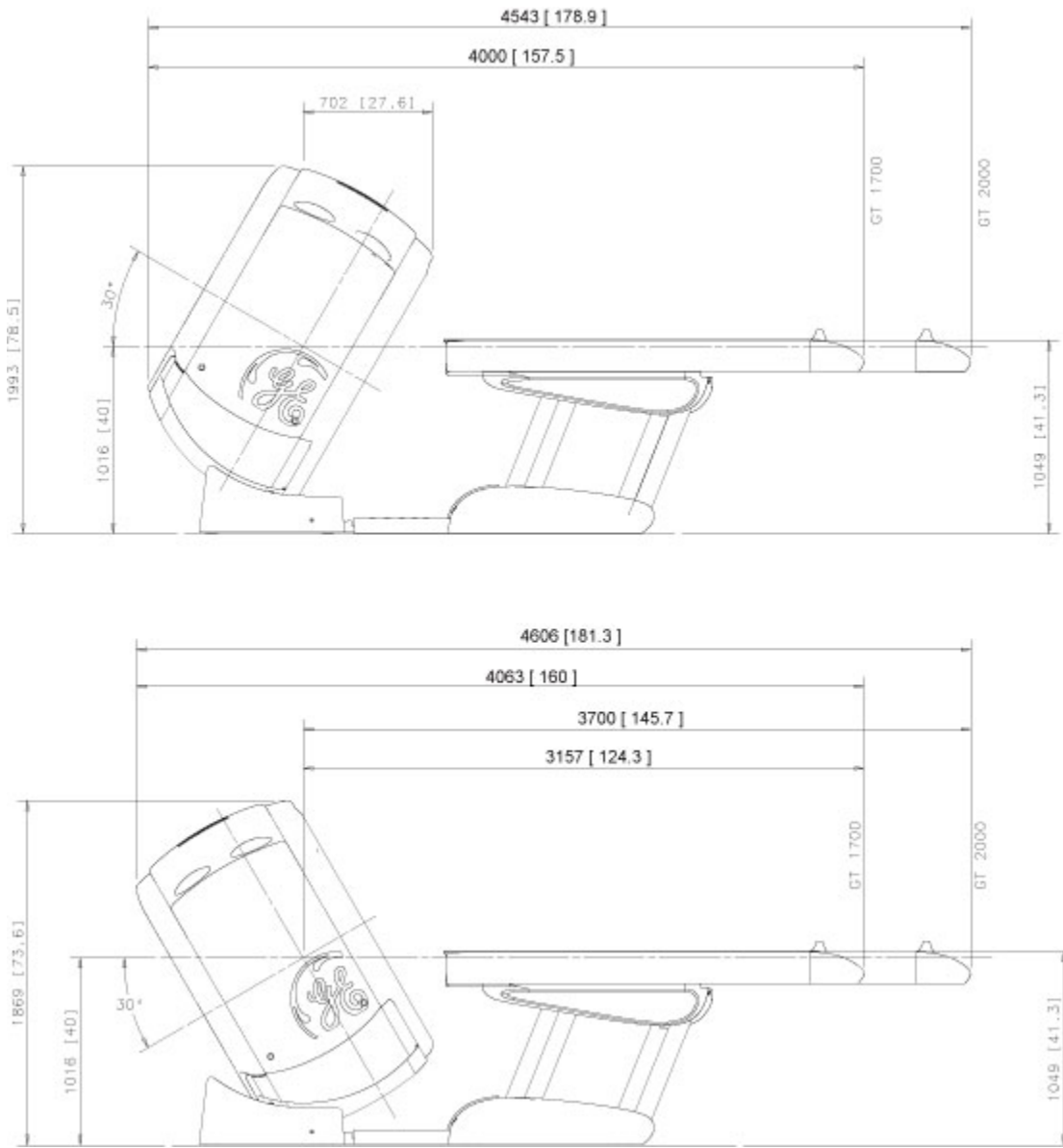

Figure 7-6 Power Distribution Unit Dimensions (NGPDU-6)

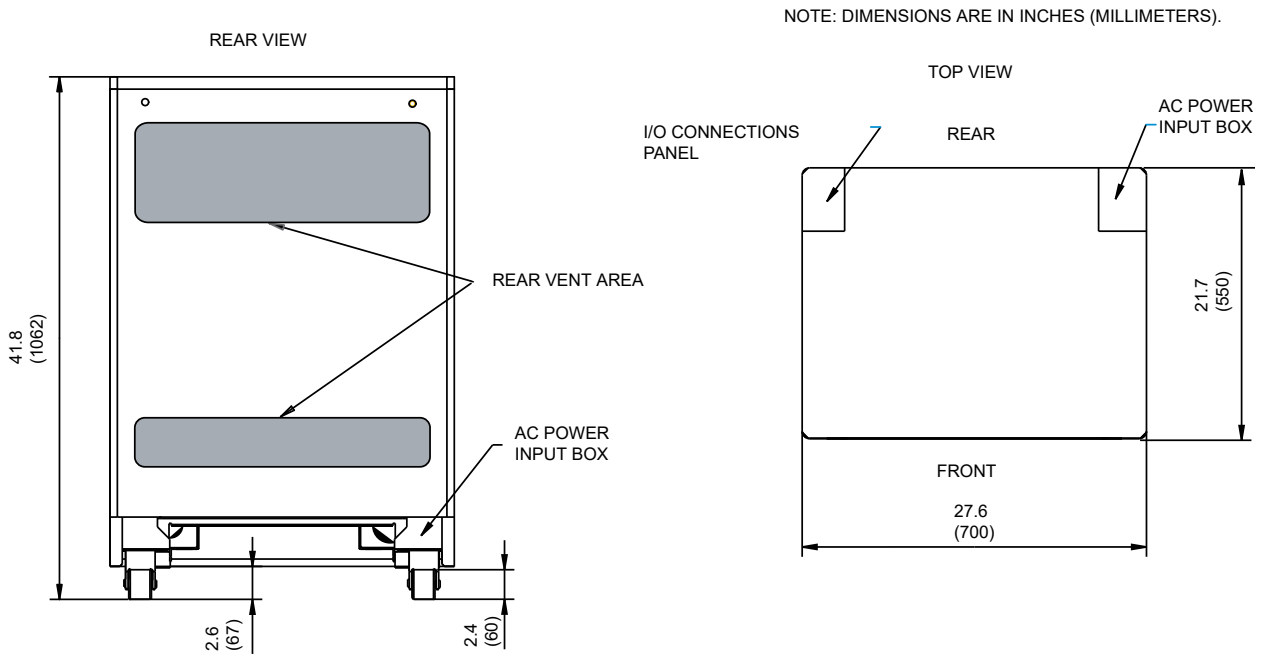

Figure 7-7 Power Distribution Unit Air intake and service areas

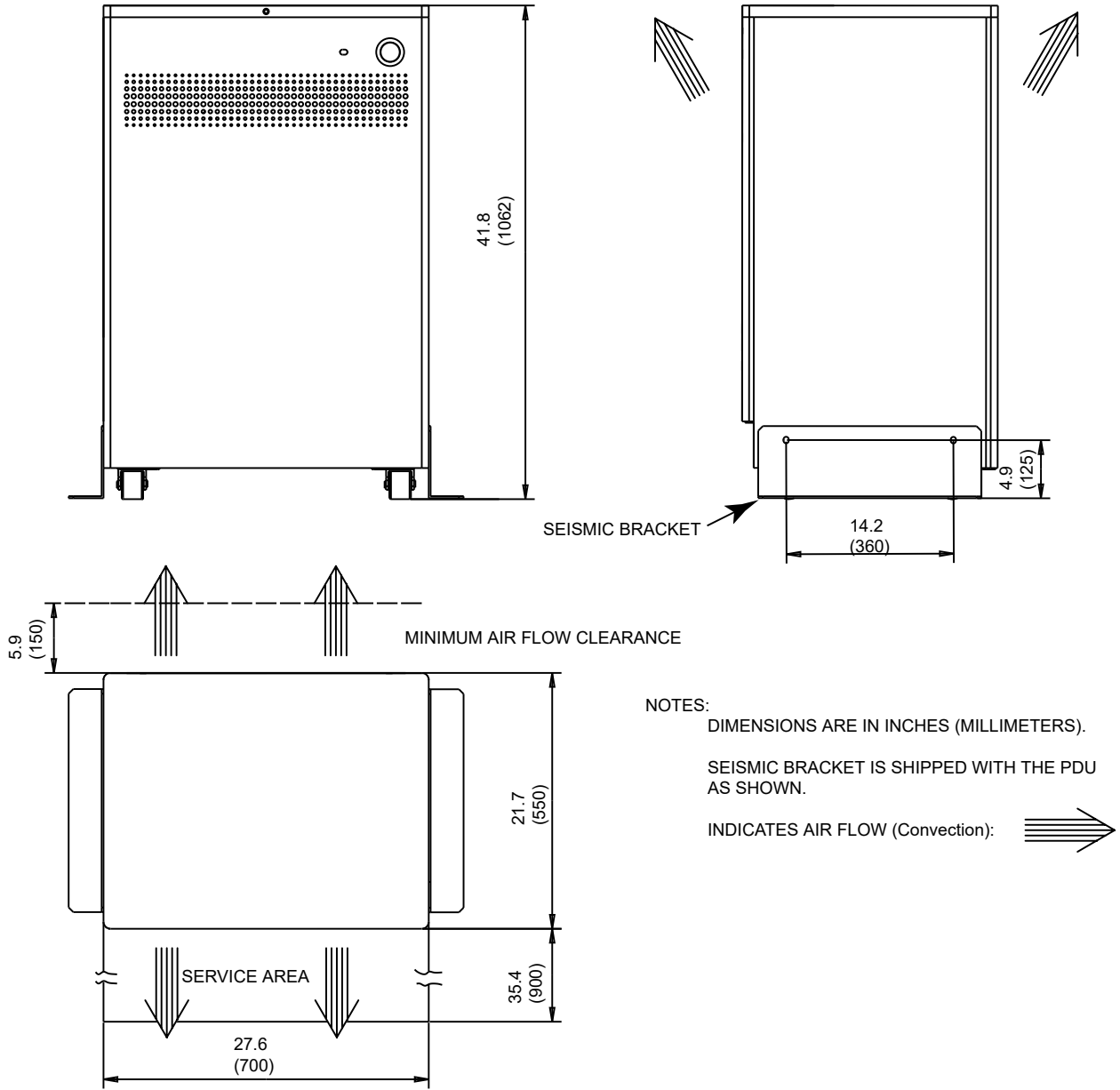

Figure 7-8 Operator Console GOC6.X

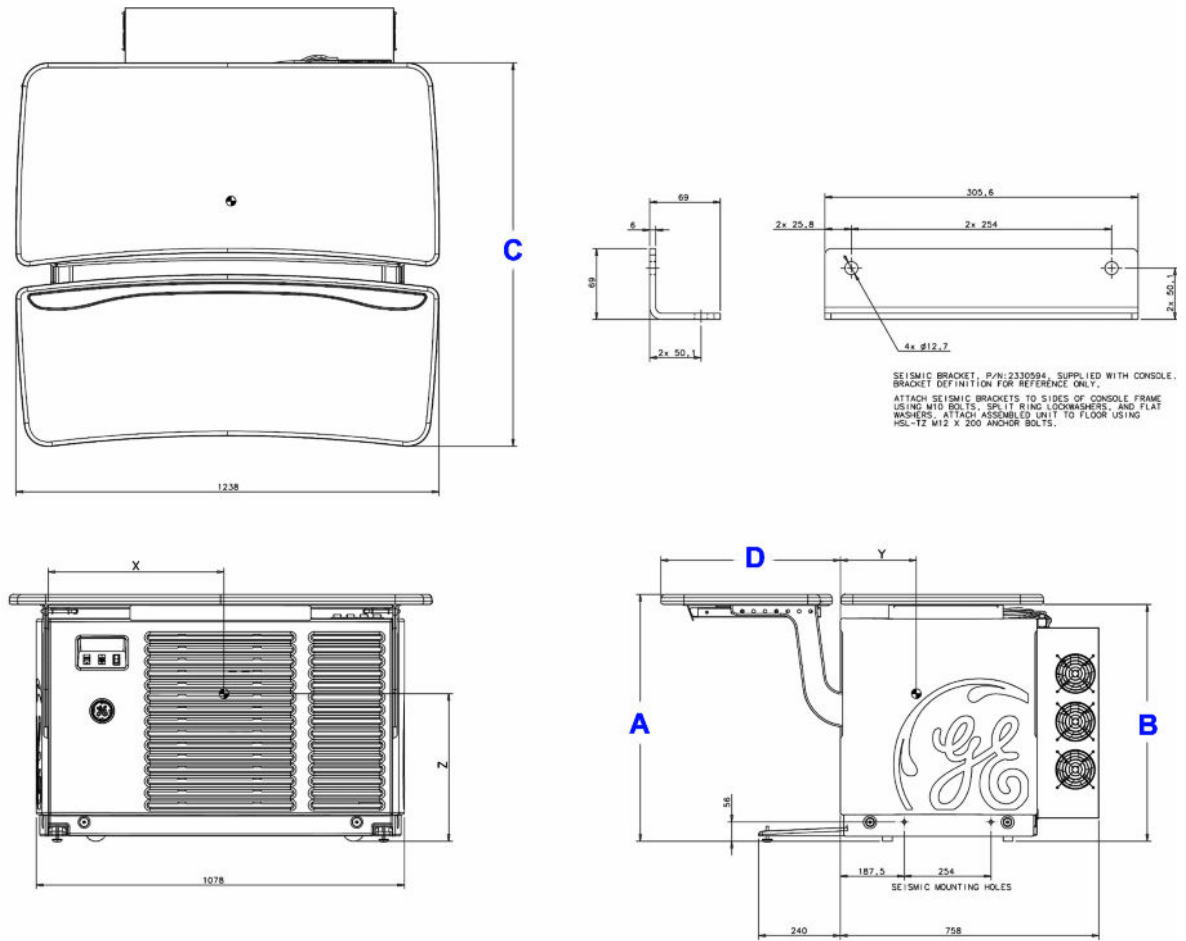

Table 7-2 Console Dimensions from Illustration above

Dimension	Minimum - mm (in)	Maximum - mm (in)	Clearance
A	680 mm (26.7 in)	883 mm (34.7 in)	Minimum clearance between the backside of the console and the wall is 52 mm (6 in) .
B	680 mm (26.7 in)	807 mm (31.7 in)	
C	1020 mm (40.1 in)	1228 mm (48.3 in)	
D	426 mm (16.7 in)	634 mm (24.9 in)	

Table 7-3 Dimensions of Accessories

Description	Width	Depth	Height
Remote Color Monitor (LCD)	413 mm (16.5 in)	203 mm (8 in)	406 mm (16 in)

Figure 7-9 Operator Console NIOHD64

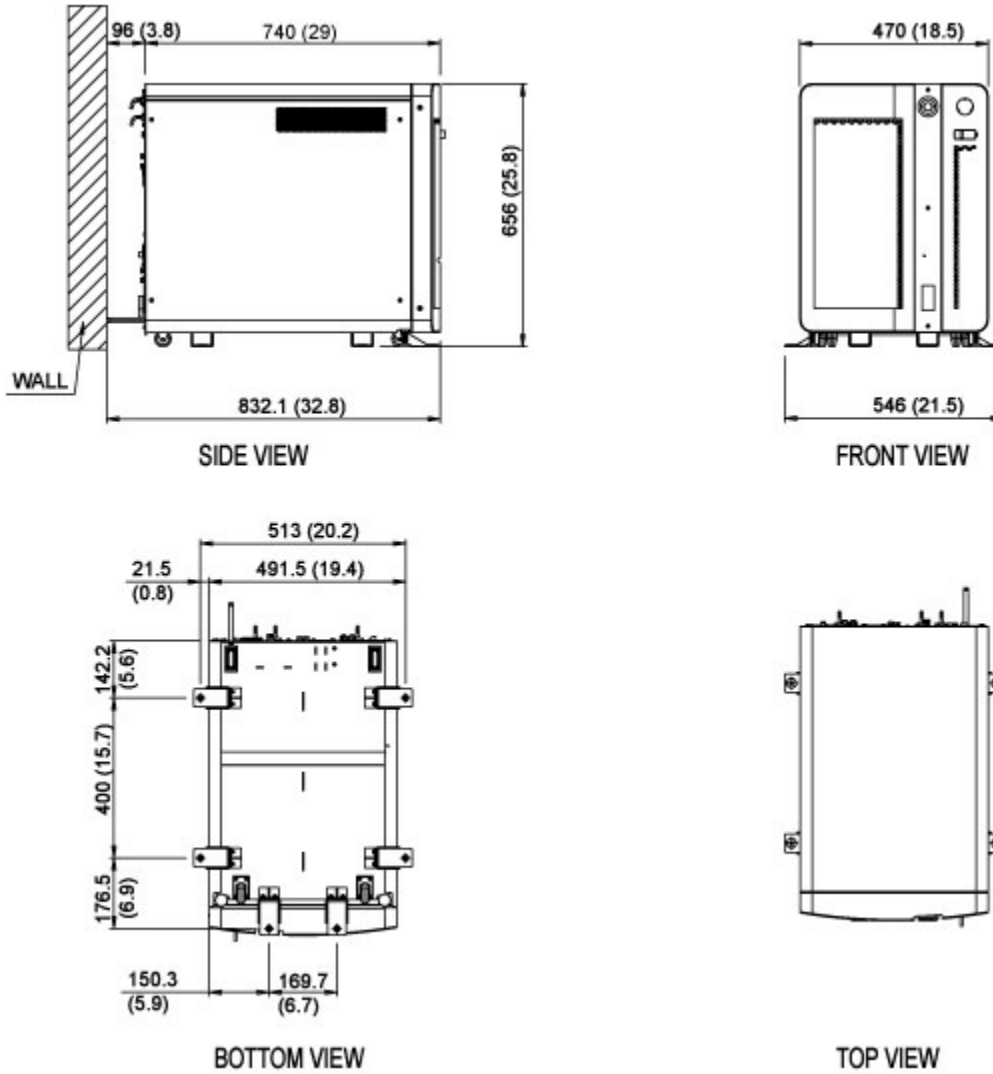

Table 7-4 Dimensions of NIOHD64 Console

Description	Width	Depth	Height	Weight
NIOHD64 Operator Console	470 mm (18.5 in)	738 mm (29 in)	655 mm (25.8 in)	71.2 kg (156.8 lb) (without package) 97.5 kg (214.8 lb) (with package)

Figure 7-10 Open Console with Z840 Host PC

Unit: mm (in)

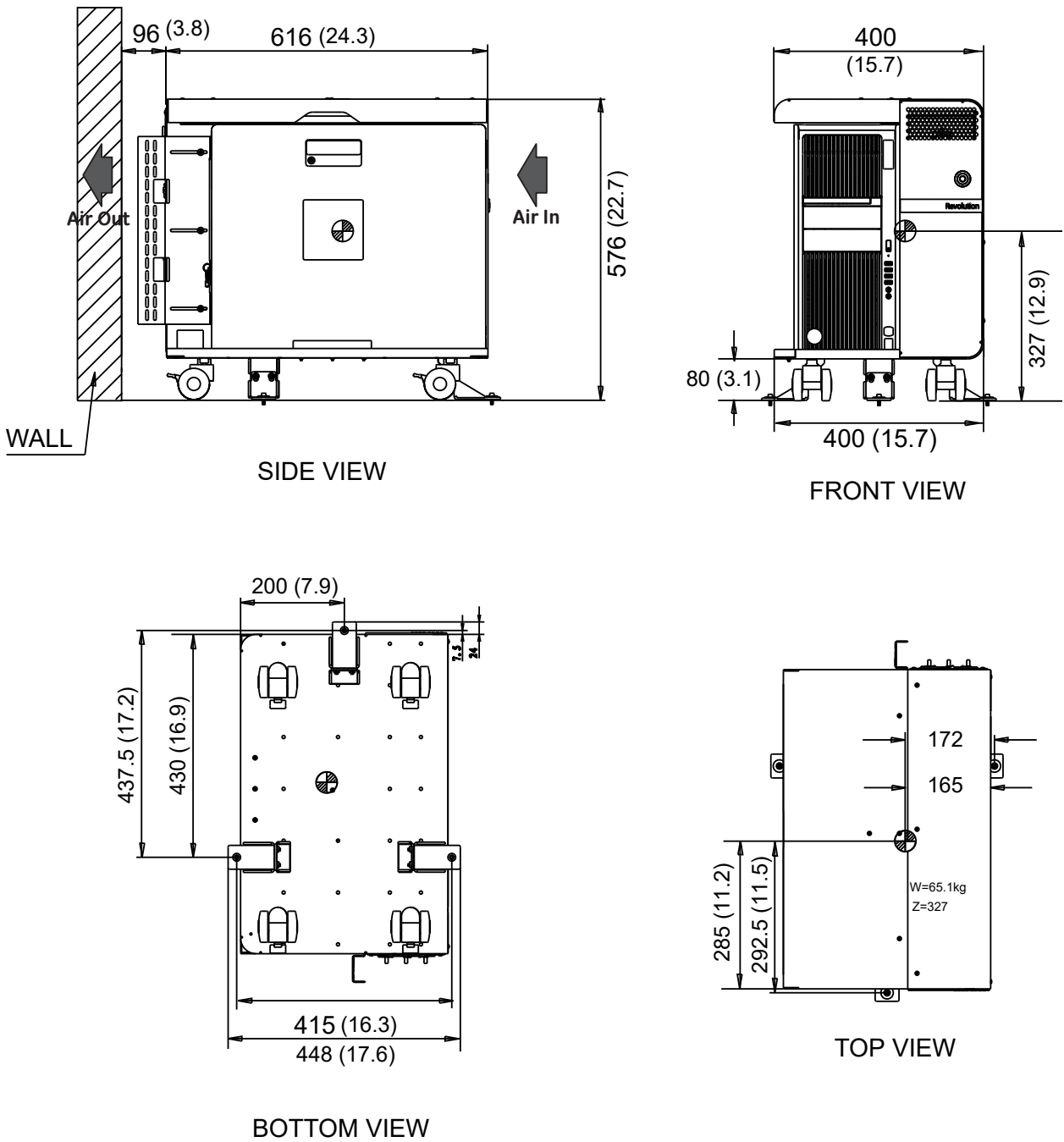

Table 7-5 Dimensions of Open Console with Z840

Description	Width	Depth	Height	Weight
Open Console	400 mm (15.7 in)	672 mm (26.5 in)	576 mm (22.7 in)	65.1 kg (143.4 lb) (without package)
				91 kg (200 lb) (with package)

Figure 7-11 Open Console with Z8G4 Host PC

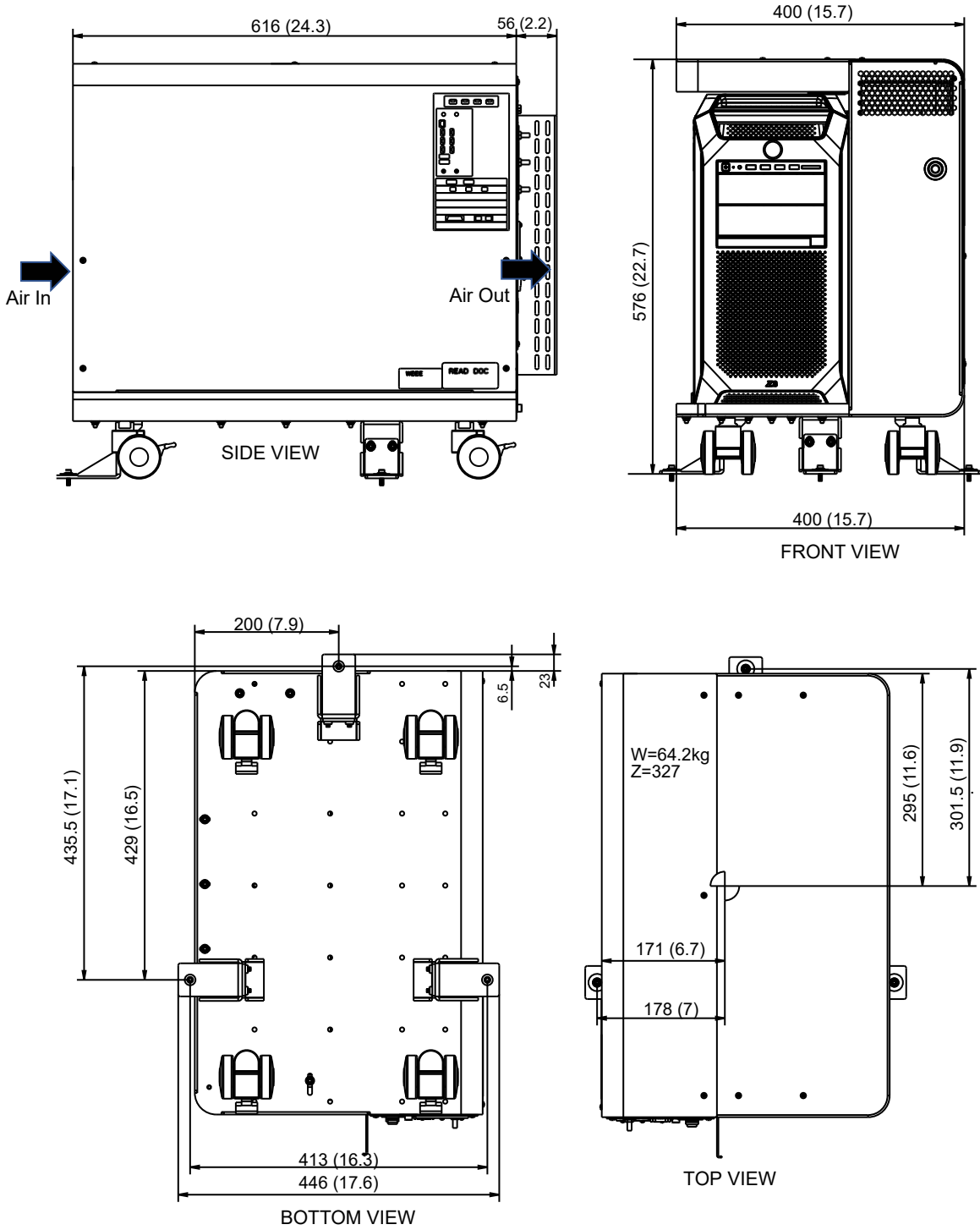

Table 7-6 Dimensions of Open Console with Z8G4

Description	Width	Depth	Height	Weight
Open Console with Z8G4	400 mm (15.7 in)	672 mm (26.5 in)	576 mm (22.7 in)	64.5 kg (142.2 lb) (without package)
				90.5 kg (199.5lb) (with package)

Figure 7-12 Smart Workspace Desk (SWS)

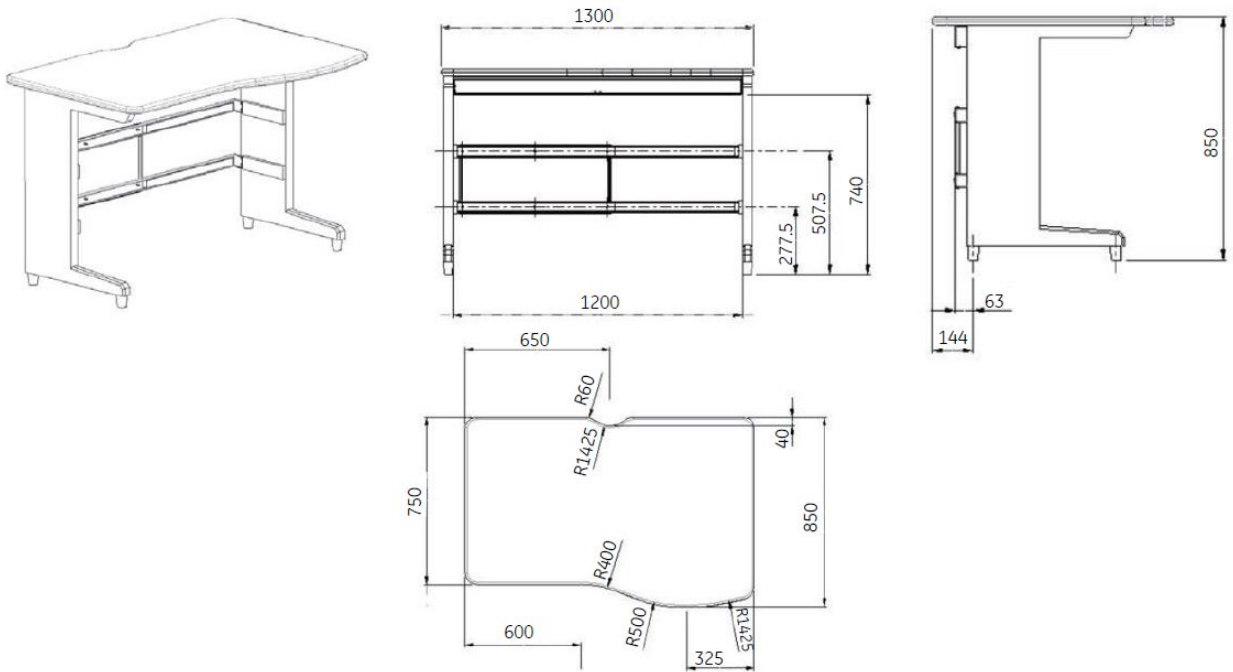

Table 7-7 Dimensions of Smart Workspace Desk

Description	Width	Depth	Weight
Smart Workspace Desk	1300 mm (51 in)	850 mm (33 in)	40 kg (88 lb)

Chapter 8 Structural and Mounting Requirements

8.1 Structural and Mounting Requirements

Importance of meeting structural requirements

System performance specifications require close consideration of the customer's floor properties. The information in this chapter provides critical information and guidelines that the customer or PMI should communicate to the architect, structural engineer, and contractor prior to construction or renovation. Failure to properly evaluate the customer's floor and ceiling properties may result in limited performance and possible safety hazards.

Levelness, Vibration, and Floor Loading All floors, whether configured to use the recommended GE-supplied anchoring system or an equivalent anchoring method, must meet the requirements for levelness, vibration, and floor loading listed in this chapter.

Seismic Loading Local laws and building codes in some areas may require the customer's contractor and structural engineer to consider seismic loads. This chapter provides the information necessary for the customer's contractor and structural engineer to complete the proper seismic calculations.

Anchoring All the information is listed in this chapter that is necessary for the customer's contractor and structural engineer to properly implement the GE-supplied anchoring system, if appropriate for the site. Please note that local laws, building codes, seismic considerations, and building or structural limitations may require the use of anchoring methods other than the GE-supplied anchoring system. In such cases, responsibility for providing an equivalent anchoring method rests solely with the customer's contractor or structural engineer.

Consult your architect, structural engineer, contractor, or PMI to resolve any questions.

NOTICE

Responsibility for providing an approved support structure and mounting method for all floor types, other than those listed in this chapter, rests with the purchaser. General Electric accepts no responsibility for any failure of the support structure or anchoring method, including seismic mounting and anchoring. General Electric accepts no responsibility for methods other than those listed.

Ceiling Requirement

Regulatory Requirements

For systems with Suspension Options (Boom-in-Room or Depth Camera etc...), the overhead suspension shall be installed by strictly following the GEMS installation instruction. The system manufacturer specifically disclaims any and all liability arising out of or relating to the use or performance of the suspension (including cables), including, without limitation, any liability or claims relating to patient injury, death, or the reliability of such suspension.

Where a Junction Plate is supplied and installed by the Purchaser of the system, the installation plate should comply with the applicable Regulation enforced in the country.

 **WARNING**

The customer's architect is responsible for designing and installing the Junction Plate. The system manufacturer will NOT inspect and test that the Junction plate meets the loading capacity specified (recommend a 6x safety factor).

Ceiling Requirement for Boom-in-Room (B7710LN)

The minimum ceiling height above the table and gantry shall measure at least 2286 mm (90 in) or the minimum distance allowed by local laws and codes, whichever is greater, when measured from the floor to the finished ceiling. The purchaser or their contractor shall complete the installation of all pedestals for ceiling mounted components. The PMI will provide the necessary bolt hole information upon request.

The support structure for a ceiling mounted option using a Mavig pedestal, requires a flush ceiling mounting plate. This flush ceiling mounting plate must be designed by a structural engineer and installed by a qualified contractor prior to the system installation.

Ceiling Mounted Devices

If a ceiling mounted injector, remote monitor or other device is installed, it should be mounted in a position that allows for adequate patient and site personnel access to the table and gantry. It should not obstruct access to the gantry operator controls or interfere with patient loading. Refer to the table entitled **Minimum Dimensions and Operational Clearances** in *System Component Dimensions* chapter for minimum clearance requirements between the lowest points of the fixed ceiling mounted device and finished floor. The installation of any ceiling mounted device not specifically installed by GE Healthcare personnel shall be completed by the purchaser or their contractor. The GE Healthcare Project Manager will provide the necessary bolt hole information upon request.

**NOTE**

If a ceiling mounted boom-in-room monitor, it should NOT be mounted another arm with equipment (like injector etc..) on the same pedestal ceiling.

Pedestal Mounting Plate (Supplied by Customer)

The pedestal ceiling mount requires a flush ceiling mounting plate that is structurally supported to handle the weight of the load as shown in the illustration below. You can order a Mavig-designed ceiling plate (p/n E8007PJ / E8004NG). This 356 mm x 356 mm (14 in x 14 in) plate has pre-drilled 1/2 in mounting holes in each of the four (4) mounting corners.

Figure 8-1 Center of Gravity for Boom-in-a-Room Kits, shown on the site print

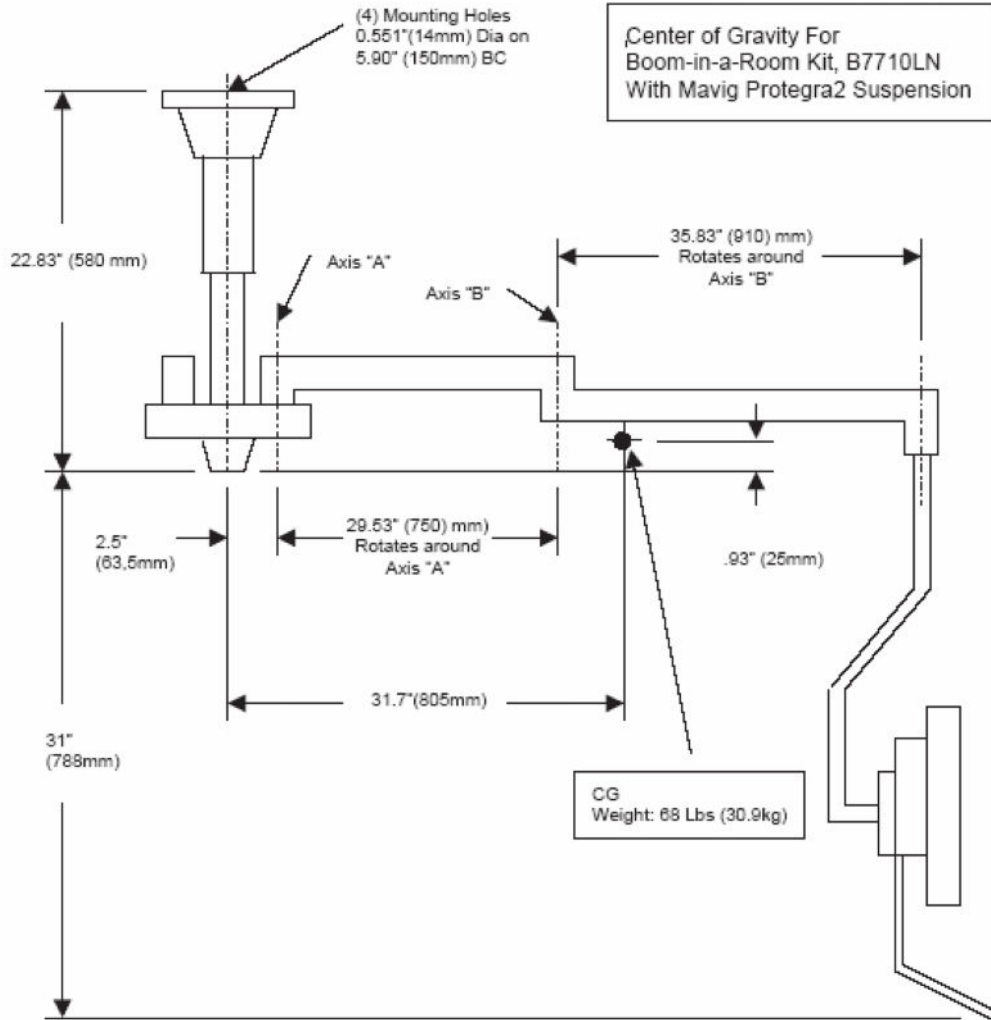

Mounting Plate for Boom-In-Room

If a structural contractor designed an equivalent plate, use the supplied template to drill the required four 0.39 in holes in a pattern as shown in the illustration below. An additional hole (0.32 in) is required for the pedestal ceiling mount safety chain.

Detailed instruction for hole size and a template is available from Mavig or in their Portegra Installation Manual.

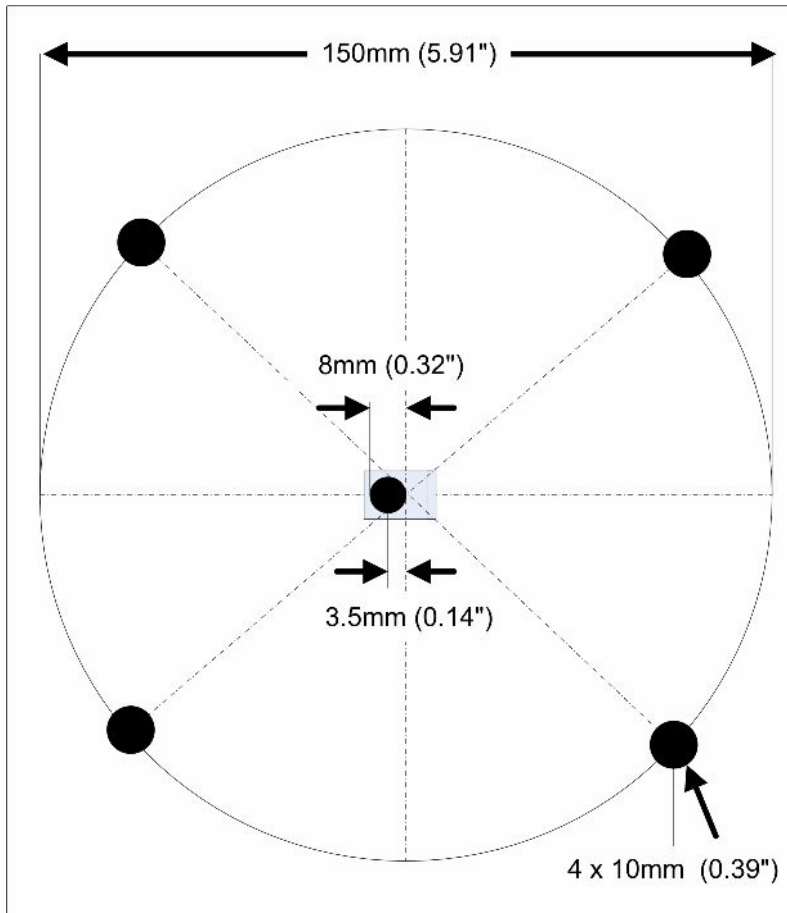
Figure 8-2 Mounting hole pattern for Mavig ceiling pedestal base**Pedestal Height Requirement**

The pedestal ceiling mount assembly must be installed at least 2134 mm (84 in) from the lowest point to the finished floor.

Junction Box Mounting Plate for Boom-In-Room

A 152 mm x 152 mm x 102 mm (6 in x 6 in x 4 in) or equivalent ceiling box is required to be flush mounted next to the ceiling plate. There should be two (2) conduits exiting into the box and the box grounded to the mounted plate. The electrical box cover plate must be flush mounted to the finished ceiling and with provision to add a 102 mm x 102 mm (4 in x 4 in) centered GE-supplied electrical cover plate.

**NOTE**

Additional mounting information is available on the Mavig website. Seismic information is also available on the same website.

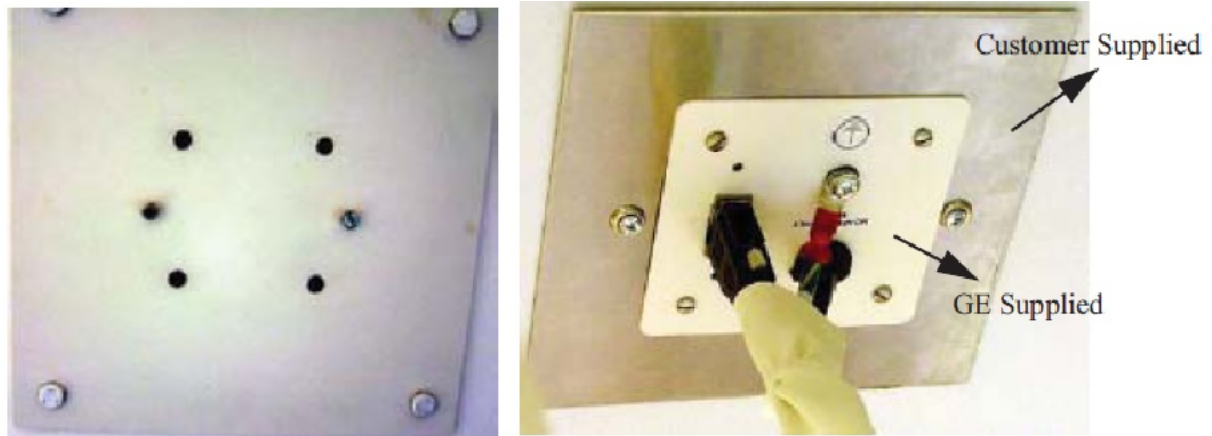
Figure 8-3 Junction Box Mounting/Ceiling Plate

Ceiling Requirements for Boom-in-Room Kit (B7710AN/B7877RU)

If customer has purchased Boom-in-Room kit (**B7710AN with Junction Box**), please refer to **Monitor-In-Room Boom Installation Manual (5620471-1EN)** from SIMS Content Viewer for details.

If customer has purchased Boom-in-Room kit (**B7710AN without Junction Box**), please refer to **Monitor-In-Room Boom Installation Manual (5914981-1EN)** from SIMS Content Viewer for details.

If customer has purchased Boom-in-Room kit (**B7877RU**), please refer to **Monitor-In-Room Boom Installation Manual (5914980-1EN)** from SIMS Content Viewer for details.

The minimum ceiling height above the table and gantry shall measure at least 2286 mm (90 in) or the minimum distance allowed by local laws and codes, whichever is greater, when measured from the floor to the finished ceiling. The purchaser or their contractor shall complete the installation of all pedestals for ceiling mounted components. The PMI will provide the necessary bolt hole information upon request.

The support structure for a ceiling mounted option using a Mavig pedestal, requires a flush ceiling mounting plate. This flush ceiling mounting plate must be designed by a structural engineer and installed by a qualified contractor prior to the system installation.



NOTE

A finished ceiling is required.

Ceiling Mounted Devices

If a ceiling mounted injector, remote monitor or other device is installed, it should be mounted in a position that allows for adequate patient and site personnel access to the table and gantry. It should not obstruct access to the gantry operator controls or interfere with patient loading. Refer to the table entitled **Minimum Dimensions and Operational Clearances** in *System Component Dimensions* chapter for minimum clearance requirements between the lowest points of the fixed ceiling mounted device and finished floor. The installation of any ceiling mounted device not specifically installed by GE Healthcare personnel shall be completed by the purchaser or their contractor. The GE Healthcare Project Manager will provide the necessary bolt hole information upon request.



NOTE

If a ceiling mounted boom-in-room monitor, it should NOT be mounted another arm with equipment (like injector etc..) on the same pedestal ceiling.

Boom Installation Typical Layout

Figure 8-4 Boom-in-Room Cables Routing with Junction Box

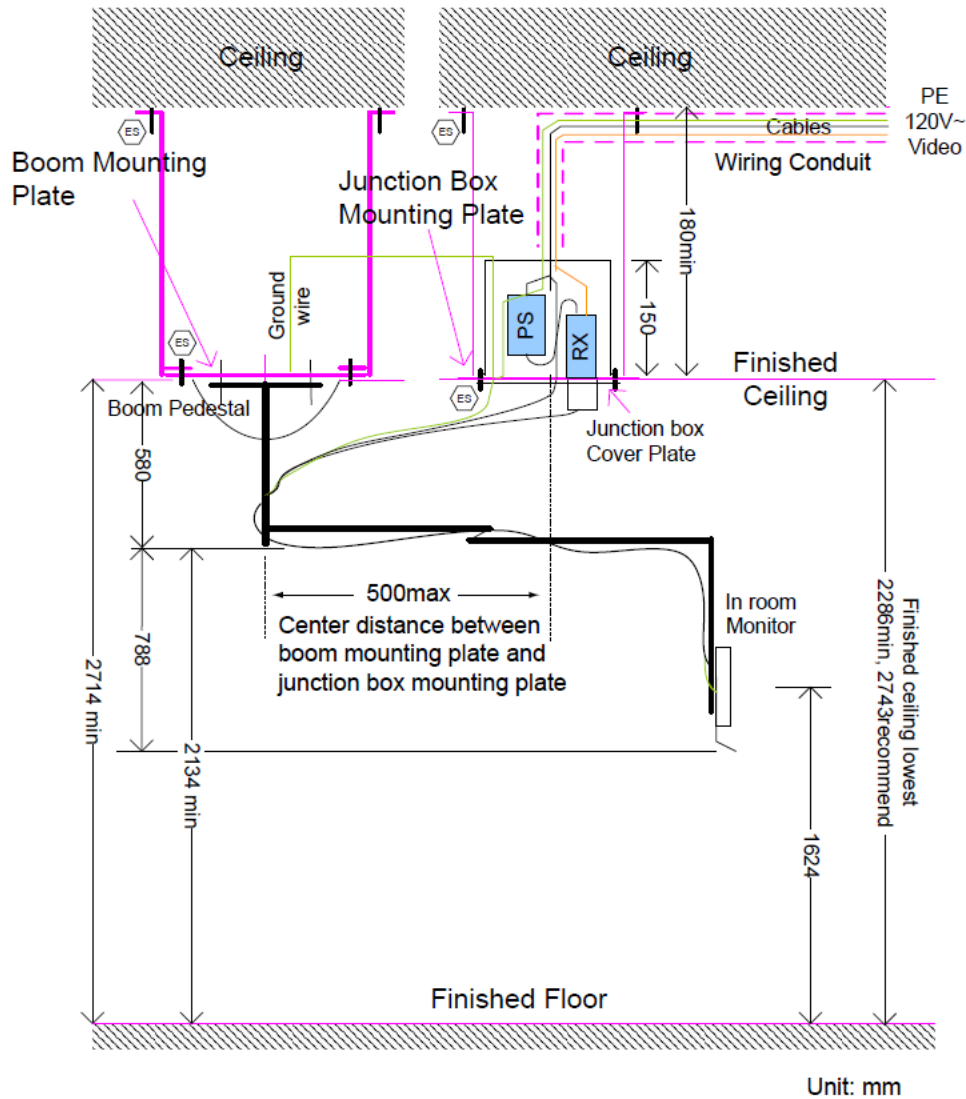

⚠ WARNING



The ceiling-mounted components should NOT touch any electricity conductive structures which are connected with power or grounding other than CT system's power and grounding, to avoid unexpected short circuit/arcing hazard.

Figure 8-5 Boom-In-Room Typical layout without Junction Box

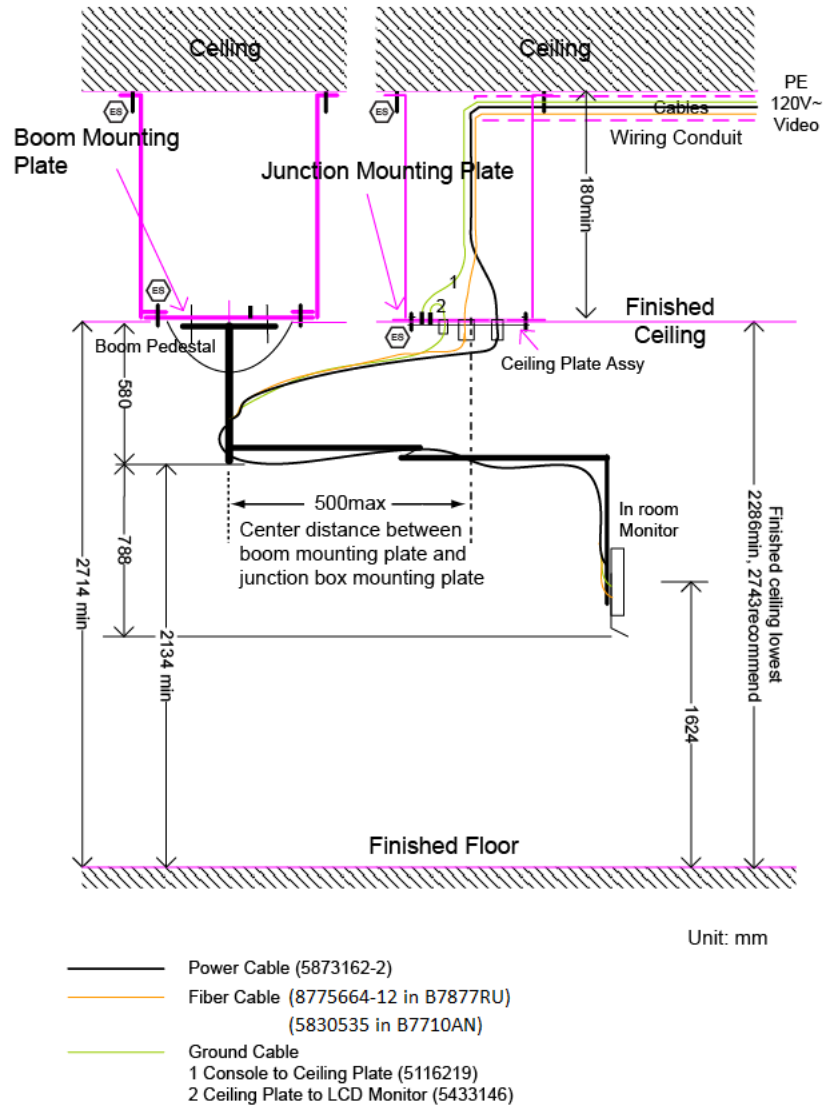

WARNING



The ceiling-mounted components should NOT touch any electricity conductive structures which are connected with power or grounding other than CT system's power and grounding, to avoid unexpected short circuit/arcing hazard.

Pedestal Mounting Plate (Supplied by Customer)

The pedestal ceiling mount requires a flush ceiling mounting plate that is structurally supported to handle the weight of the load as shown in the illustration below.

Some options may required different option plates that those listed below. Refer to the options install manual to determine which plate is required.

Figure 8-6 Center of Gravity for Boom-in-a-Room Kits - (B7710AN kit)

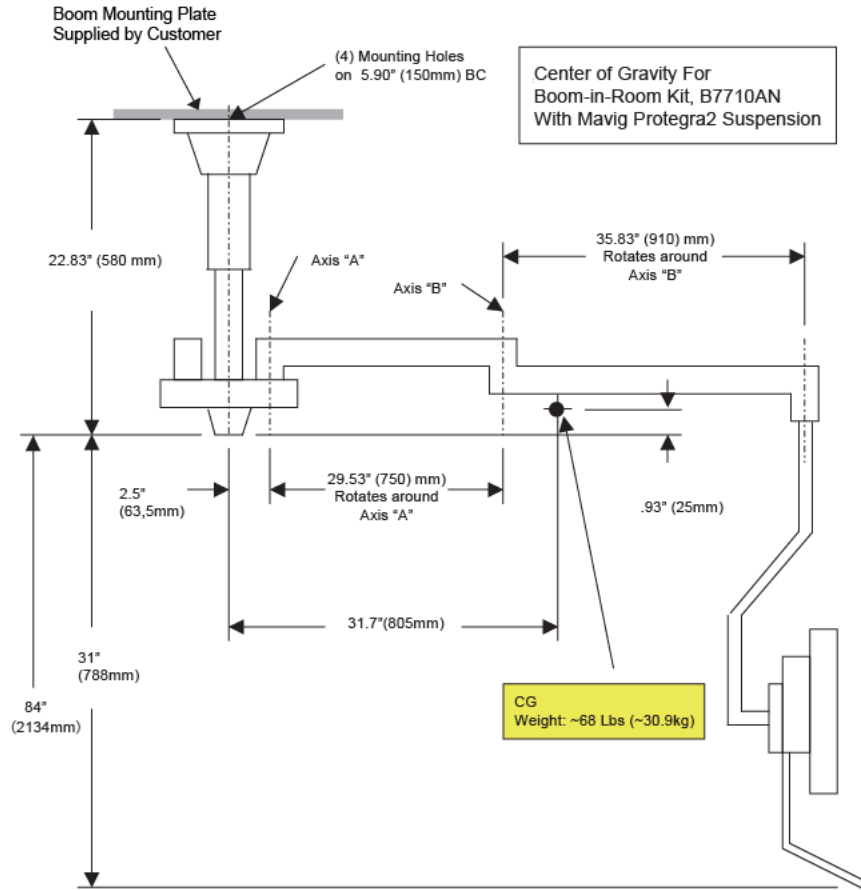
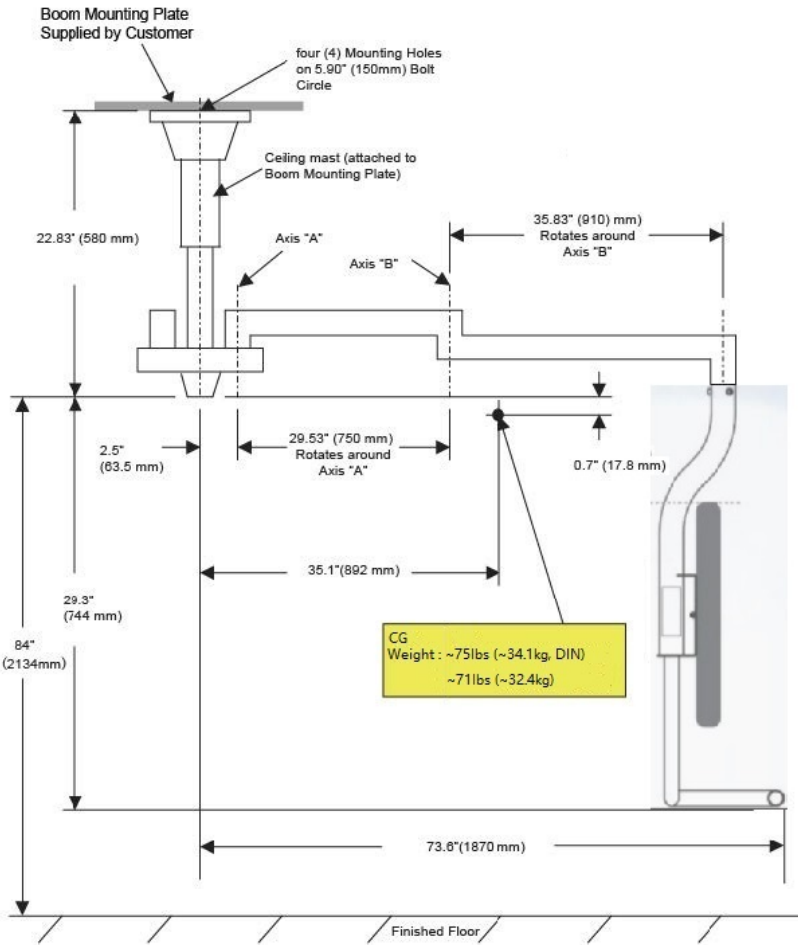

Figure 8-7 Center of Gravity (CG) for Boom-in-Room Kit- (B7877RU kit)



Mounting Plate for Boom-In-Room

If a structural contractor designed an equivalent plate, four (4) $\Phi 14$ (0.55 in.) mounting holes are required to anchor the boom pedestal (with flat washer, lock washer and hex nut) to the boom mounting plate and one M8 (0.32 in.) hole is used to anchor the safety chain bracket assembly. One $\Phi 15$ (0.59 in.) hole is used for the ground cable connection

Detailed instruction for hole size and a template is available from Mavig or in their Portegra Installation Manual. Refer to below illustration.

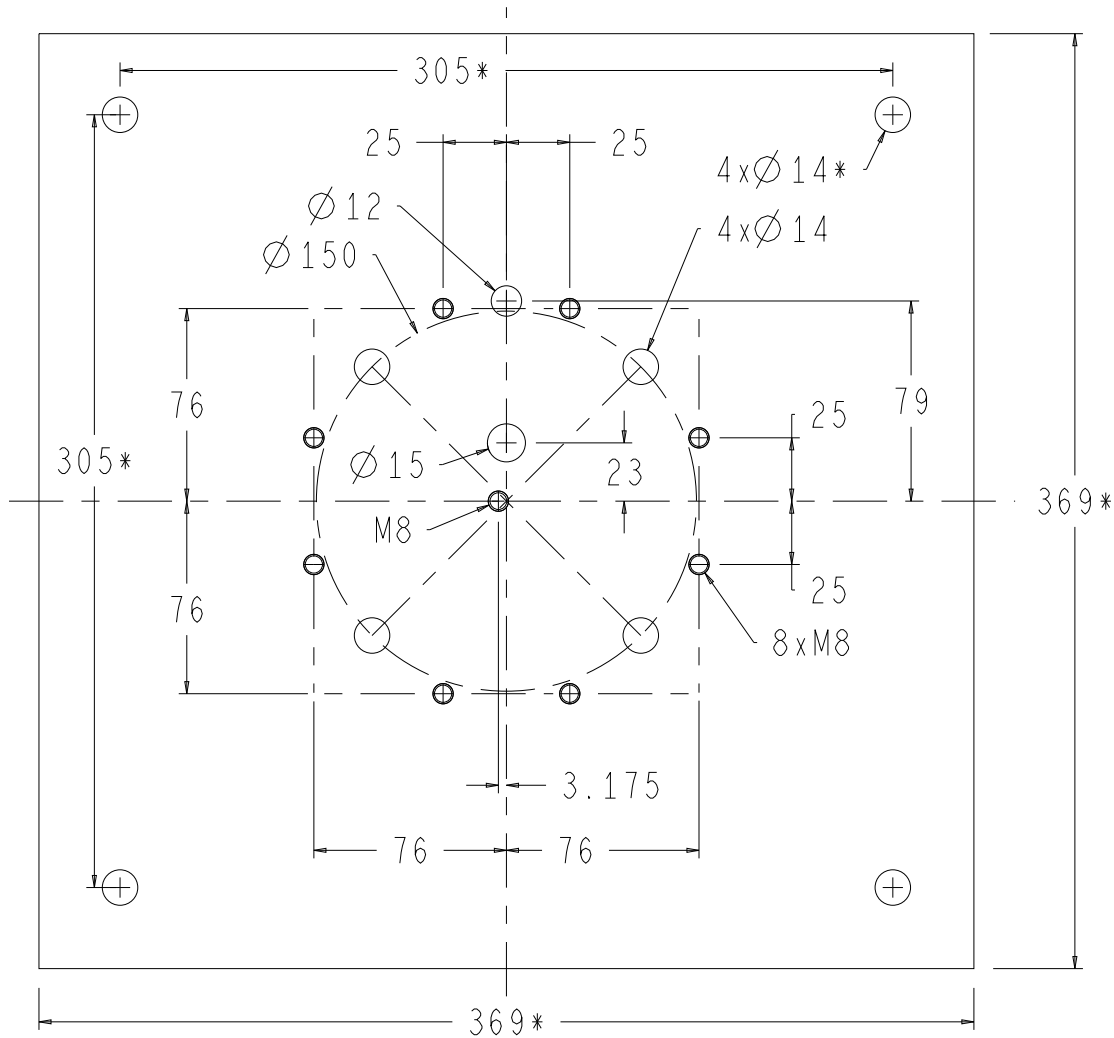
Figure 8-8 Boom pedestal mounting plate dimension**Pedestal Height Requirement**

The pedestal ceiling mount assembly must be installed at least 2134 mm (84 in) from the lowest point to the finished floor.

Junction Box / Junction Mounting Plate

A 200 mm x 200 mm x 150 mm (7.9 in x 7.9 in x 5.9 in) or equivalent junction box is required to be flush mounted next to the ceiling plate. There should be two (2) conduits exiting into the junction box and the box grounded to the mounted plate. The junction box cover plate assembly must be flush mounted to the junction box mounting plate, it's a 240 mm x 240 mm (9.4 in. x 9.4 in.) centered GE-supplied electrical cover plate assembly.

**NOTE**

Additional mounting information is available on the Mavig website. Seismic information is also available on the same website.

Figure 8-9 Junction Mounting Plate Dimension

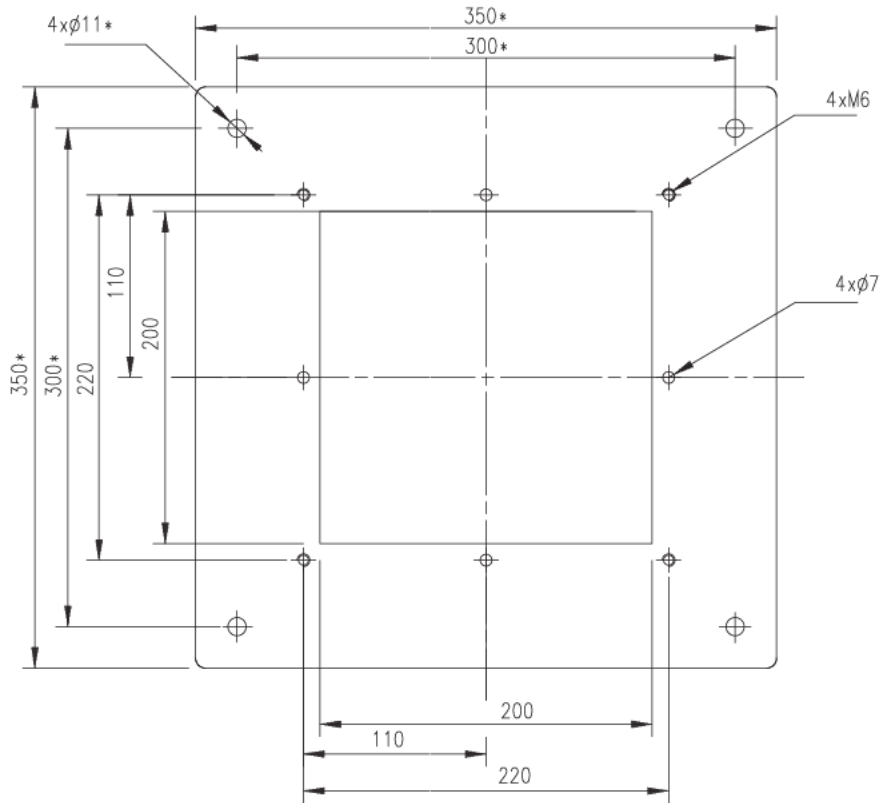

THE DIMENSIONS WITH * IS ONLY FOR CUSTERMOER REFERENCE



NOTE

Dimensions marked with an asterisk (*) above (and the available engineering drawing provided by the PMI) are for customer reference only. Since the customer supplies this plate, dimensions marked with (*) are minimum size recommendations and may vary, depending on customer ceiling layout.

Figure 8-10 Junction Mounting Plate/Ceiling Plate Assy - wih Junction Box (B7710AN Kit)

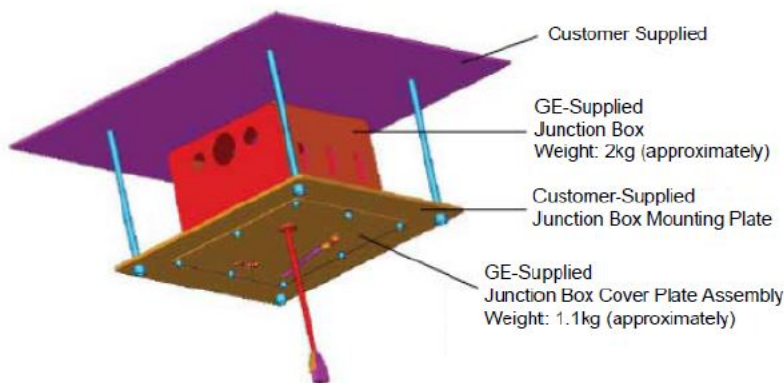
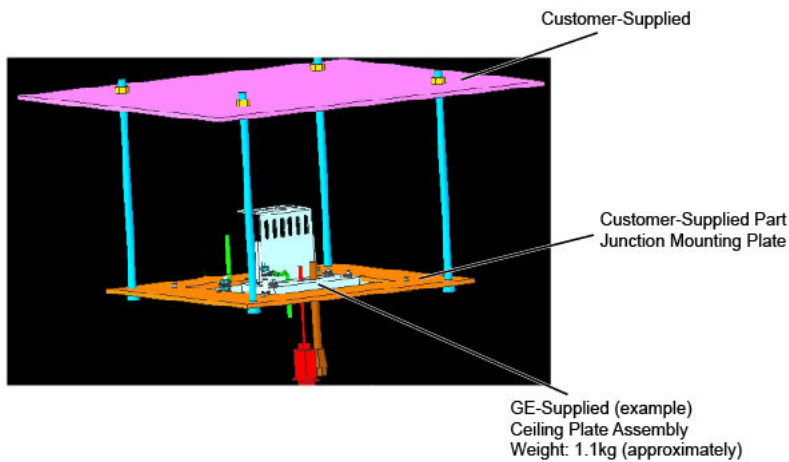

Figure 8-11 Junction Mounting Plate/Ceiling Plate Assy - without Junction Box (B7877RU Kit / B7710AN)



Ceiling Requirement for Auto Patient Positioning Depth Camera

If customer has purchased Express Mode Depth Camera Option, please refer to **Auto Patient Positioning Depth Camera Installation Manual (5809939-1EN)** from SIMS Content Viewer for details.

NOTICE

NOTE TO SITE PLANNING AND CUSTOMERS:

Though the camera coverage is defined at 100mm above isocenter, Auto Patient Positioning works at different table heights, with variable patient sizes. The technique works even if part of the patient body being scanned is out of the camera view or the patient body occupies only a smaller portion of the view, but the best accuracy is achieved when the full patient body fits the view. Appropriately choosing the desired camera coverage before camera installation can optimize the Auto Patient Positioning performance.

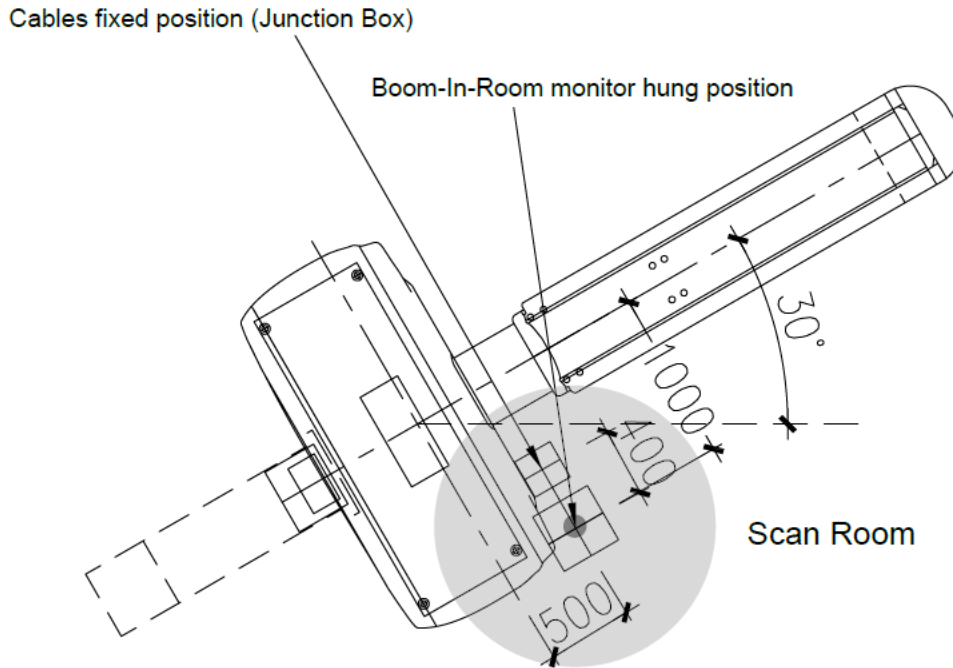
Figure 8-12 Boom-In-Room Moving Radius**CAUTION**

When moving ceiling mounting devices (In-Room-Monitor, Injector, Anesthesia Machine etc), make sure to avoid damage to the depth camera resulted from collisions by the suspension arms.

NOTICE

NOTE FOR COLLISION AVOIDANCE WITH IN-ROOM-MONITOR:

When determining the camera installation position, it's also important to avoid possible collision with the Boom-in-Room. The "upper arm" of the boom can reach a range of 850mm radius.

The camera shall be installed:

- either outside of this 850mm-radius range (the camera cover size is 360 (W)x360 (L)x180 (H) mm³).

or

- inside the range but its bottom cover is higher than the Boom upper arm. Mavig recommends no less than 579mm from finished ceiling to the column bottom. This is equivalent to 380mm between finished ceiling and the upper arm.

If the camera is installed within the boom arm reach, the customer shall be suggested to install a protective bracket beside the camera or the boom arm to avoid damage of the camera.

Depth Camera Installation Typical Layout



NOTE

The USB (5809034-3) is plenum rated, no conduit is required. However is customer chooses to run conduit it should be 20mm is size.

Figure 8-13 Room Layout

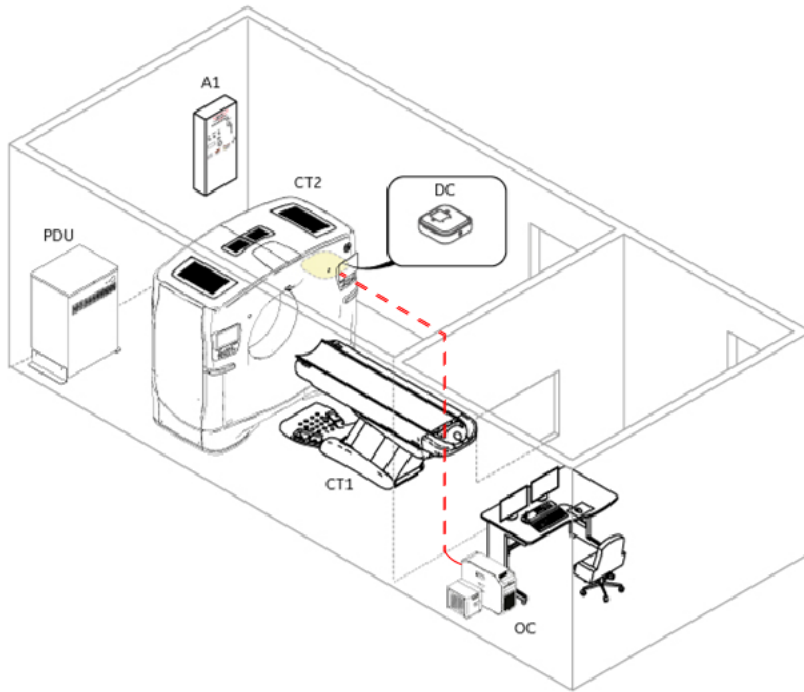

----- Depth Camera cable routing from Operator Room to Scan Room

Figure 8-14 Camera Cables Routing

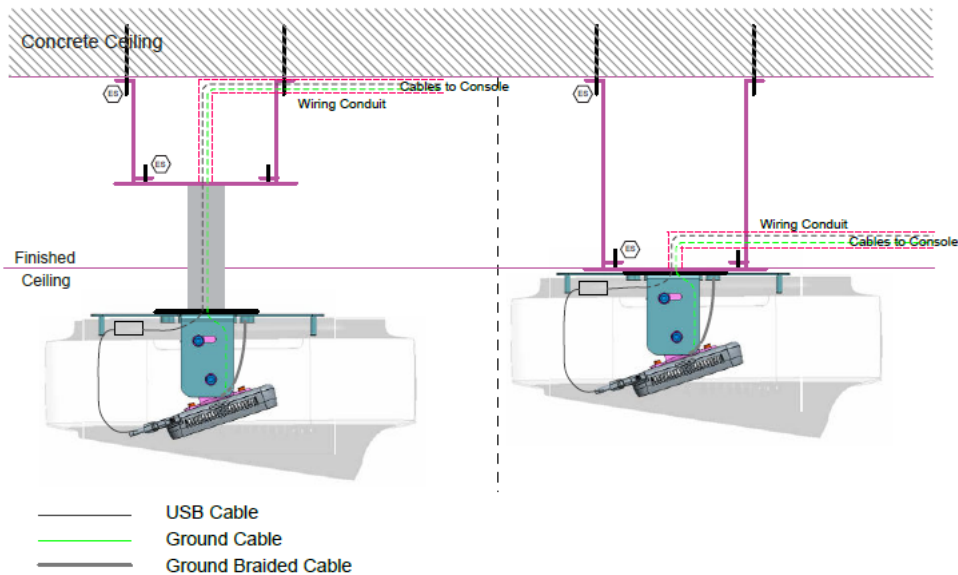

WARNING



The ceiling-mounted components should NOT touch any electricity conductive structures which are connected with power or grounding other than CT system's power and grounding, to avoid unexpected short circuit/arcing hazard.

Junction Plate Requirement

GE will provide a Junction Plate (5847942-2), shipped with the depth camera assy kit (5808502). If the Junction Plate supplied by GE can not meet the requests of the customer or the building structure, the customer's architect can design and install the Junction Plate (refer to Prepared by Customer) with sufficient strength to hold the camera assembly.

NOTICE

No matter customer uses GE junction plate or makes junction plate by themselves, customer is responsible for installing it on the concrete ceiling and meeting regulatory and GE's loading requirement.

Supplied by GE

WARNING



The system manufacturer will NOT inspect and test that the fixing methods between the Junction Plate and the building structure meet the loading capacity specified (recommend a >4x safety factor), which is the customer's responsibility.

Figure 8-15 Example for Fixing Junction Plate by using Anchor Bolts

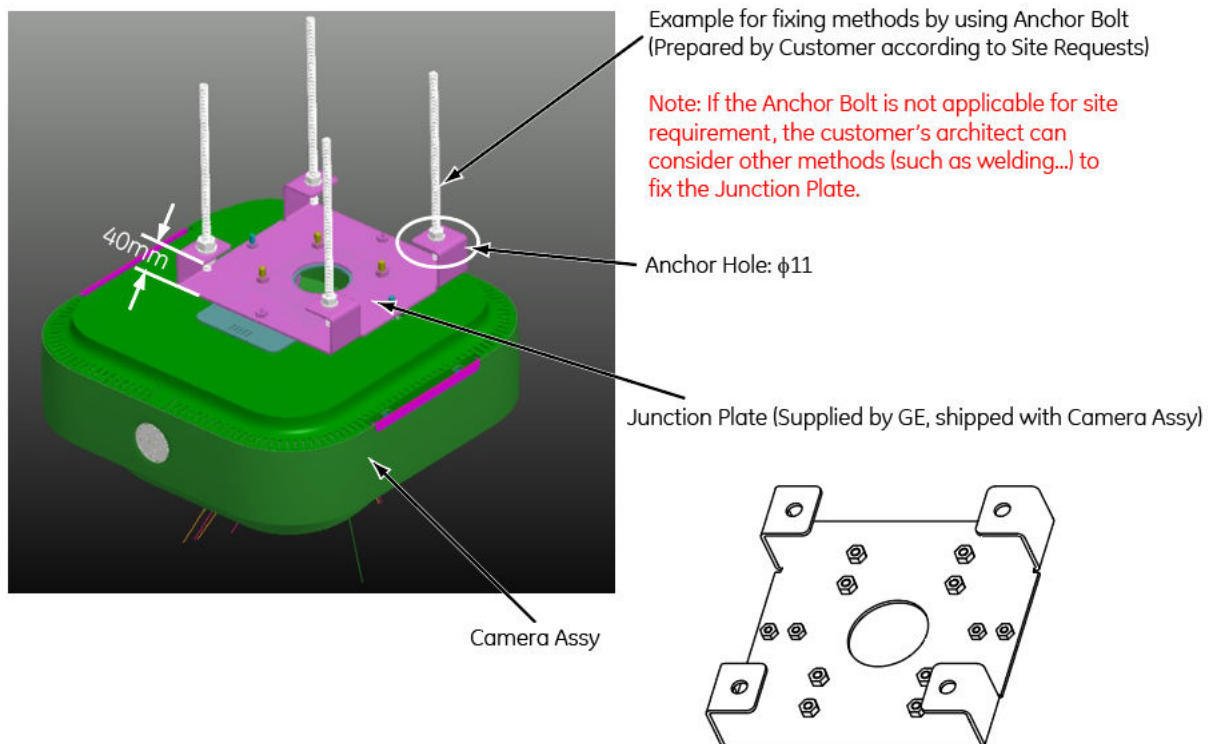
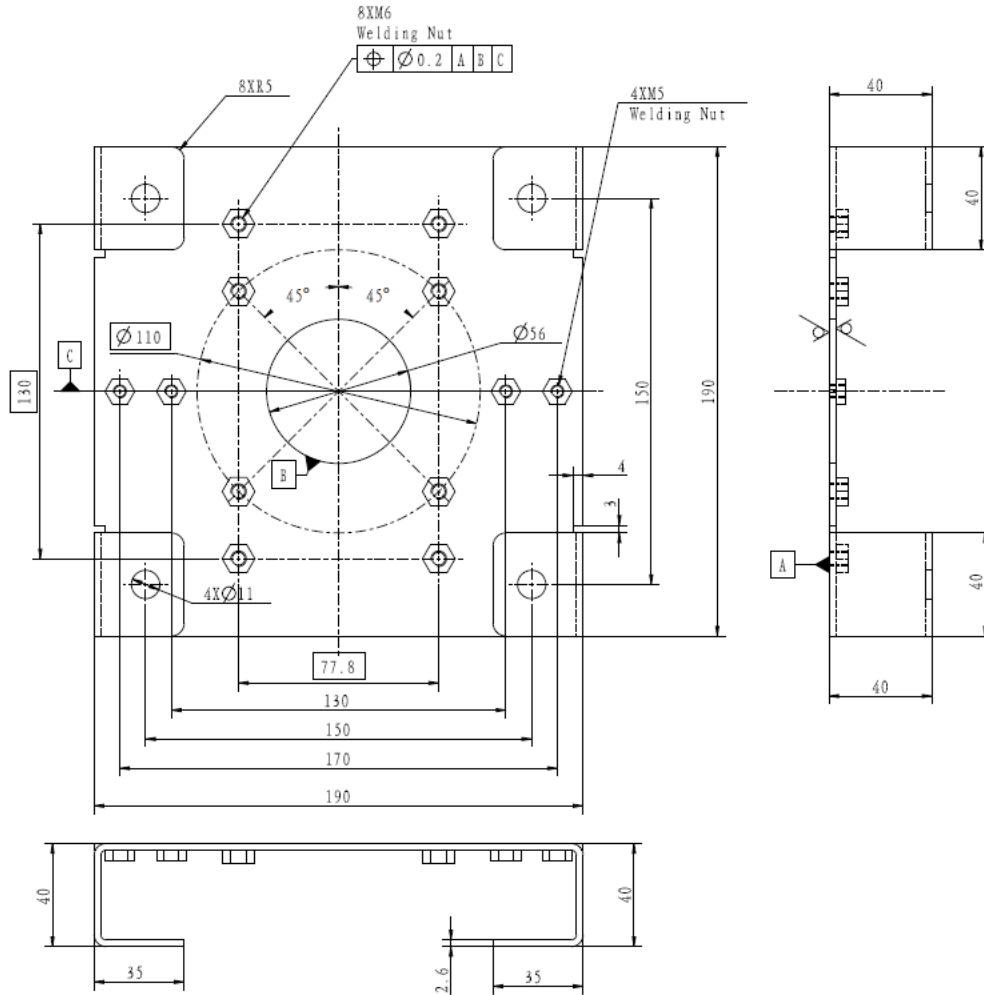

Figure 8-16 Junction Plate (Supplied by GE)



Prepared by Customer

WARNING



The customer's architect is responsible for designing and installing the Junction Plate with sufficient strength to hold the Camera Assembly. The weight of the camera assembly is approximately 3.75kg, suggest the safety load on the Junction Plate is no less than 20kg.

WARNING



The system manufacturer will NOT inspect and test that the Junction Plate meets the loading capacity specified (recommend a >4x safety factor), this is the customer's responsibility.

Figure 8-17 Junction Plate (Prepared by Customer)

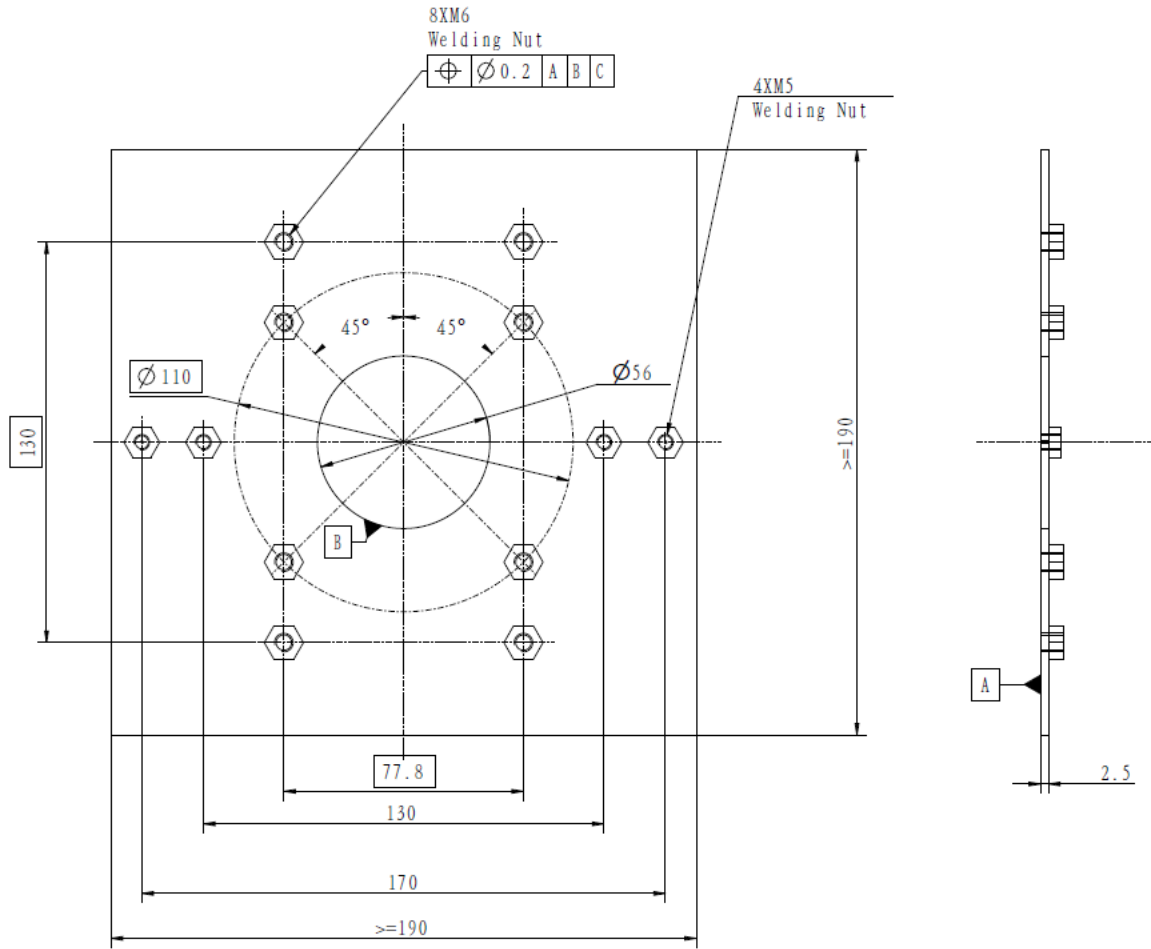

Table 8-1 Junction Plate (Prepared by Customer)

GB-T 13681-1992 Welding Nut		
	M5	M6
Thickness (mm)	3.7-4	4.7-5
Pledge Load (N)	11000	15500
Junction plate material: Steel material with a min tensile strength 375Mpa.		

Junction Plate Installation Direction

NOTICE

The Junction Plate direction should be in line with the system layout, NOT be in line with the scan room. see below figure for example of the Junction Plate direction.

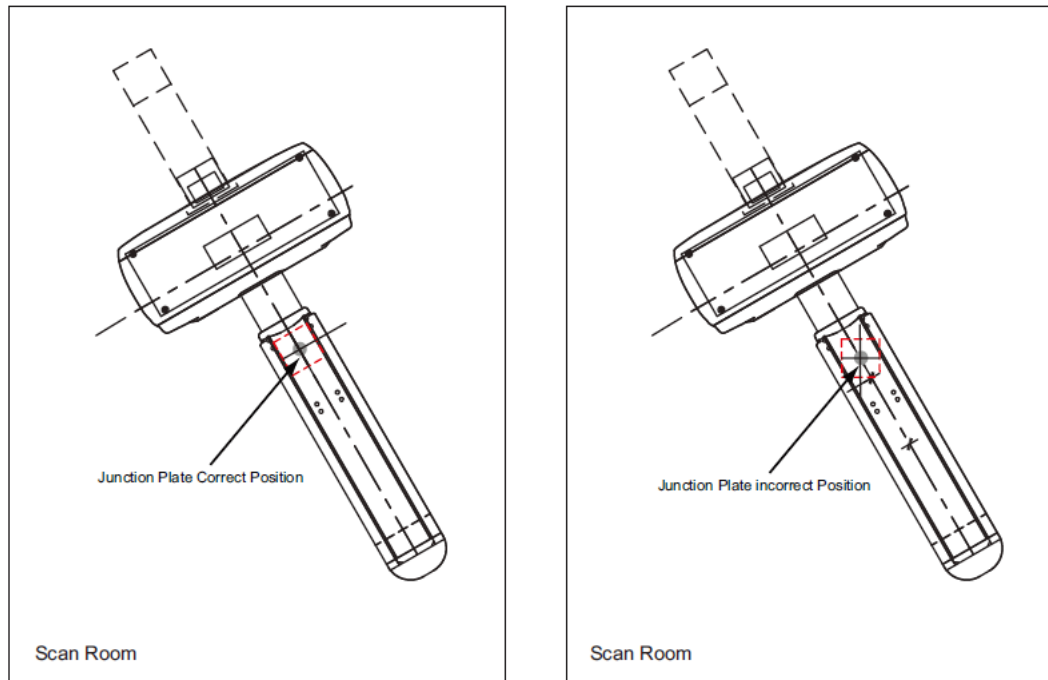
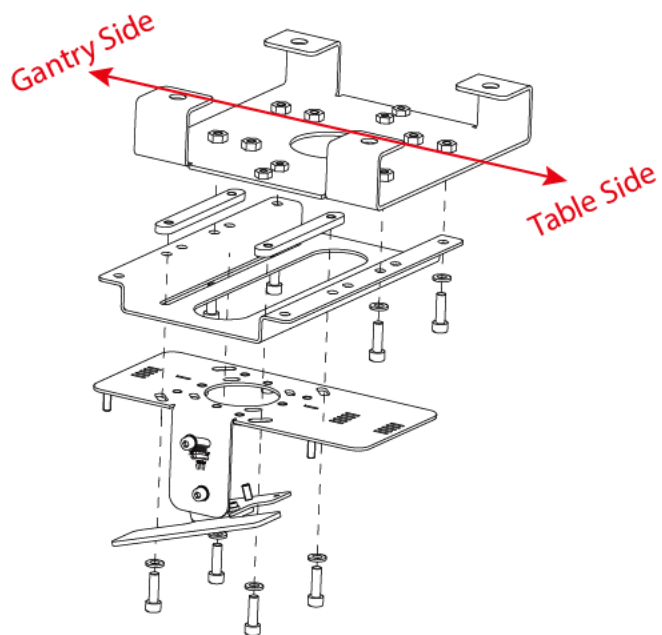
Figure 8-18 Junction Plate Installation Position**Figure 8-19 Junction Plate Installation Direction****Junction Plate Position**

When determining the camera installation position, special consideration shall be paid to the relation between the junction plate installation height and the finished ceiling height.

For the detailed procedure, please refer to **Auto Patient Positioning Depth Camera Installation Manual (5809939-1EN)**.

There are three cases for the Junction Plate installation as shown below:

- **Case A: Camera below finished ceiling**

Camera installation height is less than the finished ceiling height, customer needs order the extender kit (5821337) to install the Junction Plate 200mm or 400mm above the desired position.

Figure 8-20 Camera Installation Position_A

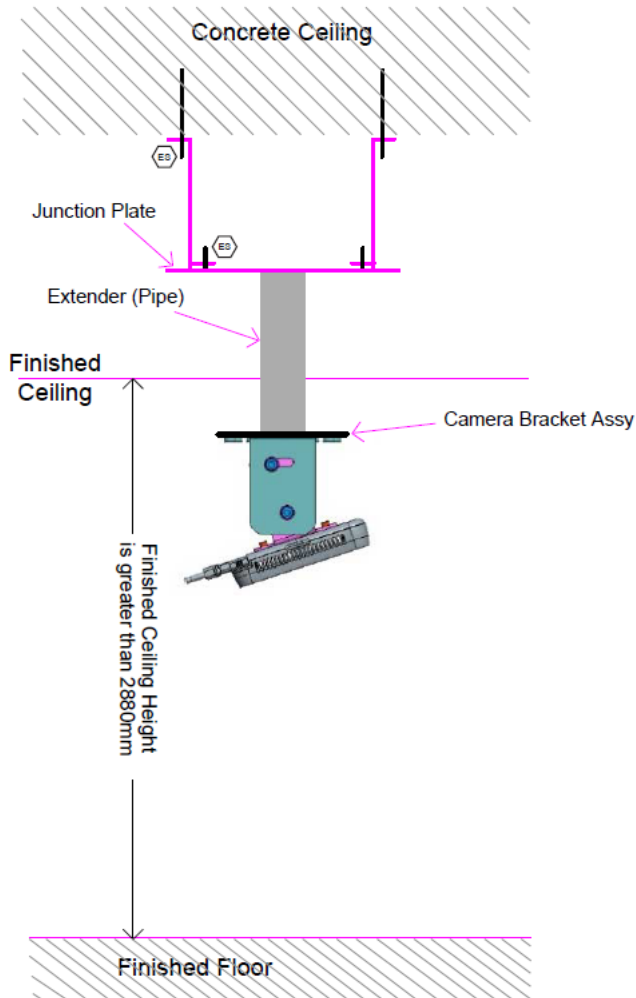

- **Case B: Camera attached to finished ceiling**

Camera installation height is equal to the finished ceiling height.

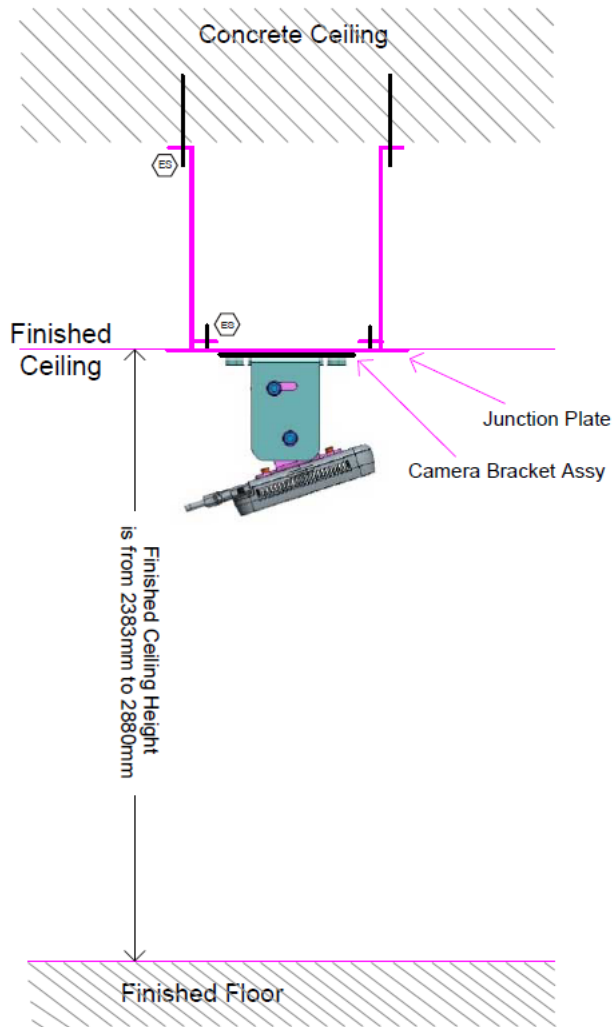
Figure 8-21 Camera Installation Position_B

- **Case C: Camera Above finished ceiling**
Camera installation height is higher than the finished ceiling upper surface height, a rectangle hole needs to be opened in the finished ceiling as requested.

Figure 8-22 Camera Installation Position_C

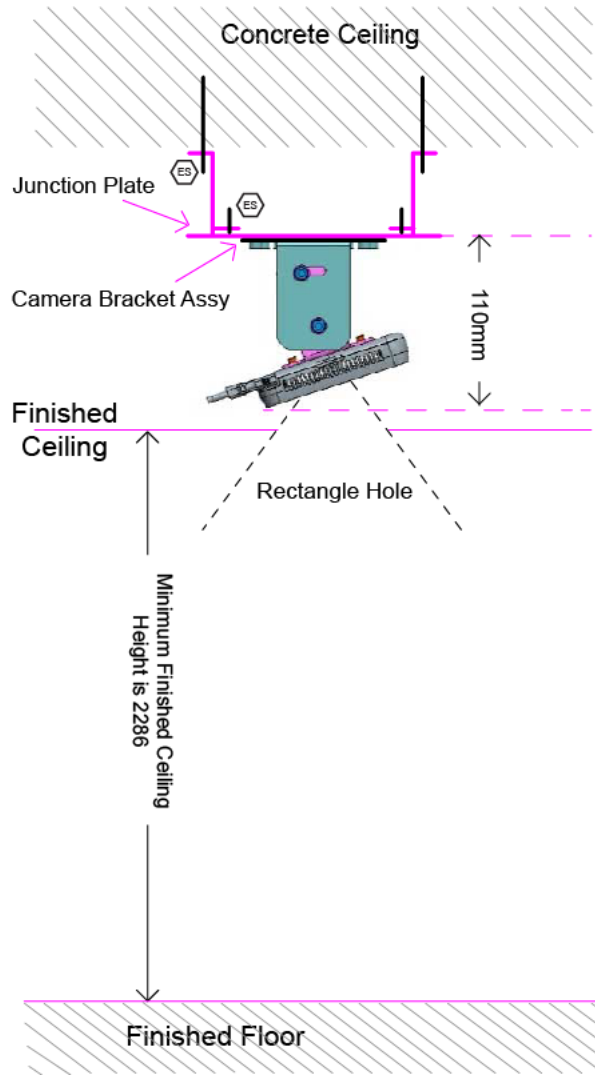

NOTE

Installation height of the Camera Bracket should be within 2383 ~ 2880mm regardless of finished ceiling height or junction plate height.

Figure 8-23 Camera Bracket Height

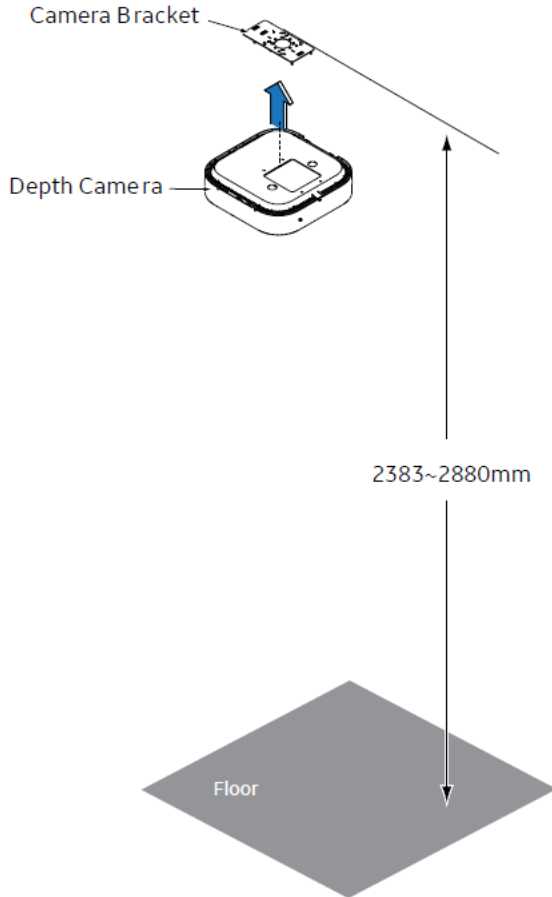

Ceiling Requirement for AVIMOS Camera

AVIMOS needs the cameras to get the property video for doctor/technologist to view the gantry internal / external laser lines, table movement and monitor patient. Then particular area/sharpness for each video is required. Where to locate the camera and how to adjust direction is important.

If customer has purchased RCK with AVIMOS kit, please refer to **Remote Control Kit with Assisted Video Monitoring System Manual (5863844-1EN)** from SIMS Content Viewer for details.

AVIMOS Camera Installation Typical Layout

Figure 8-24 RCK-AVIMOS Schematics Diagram

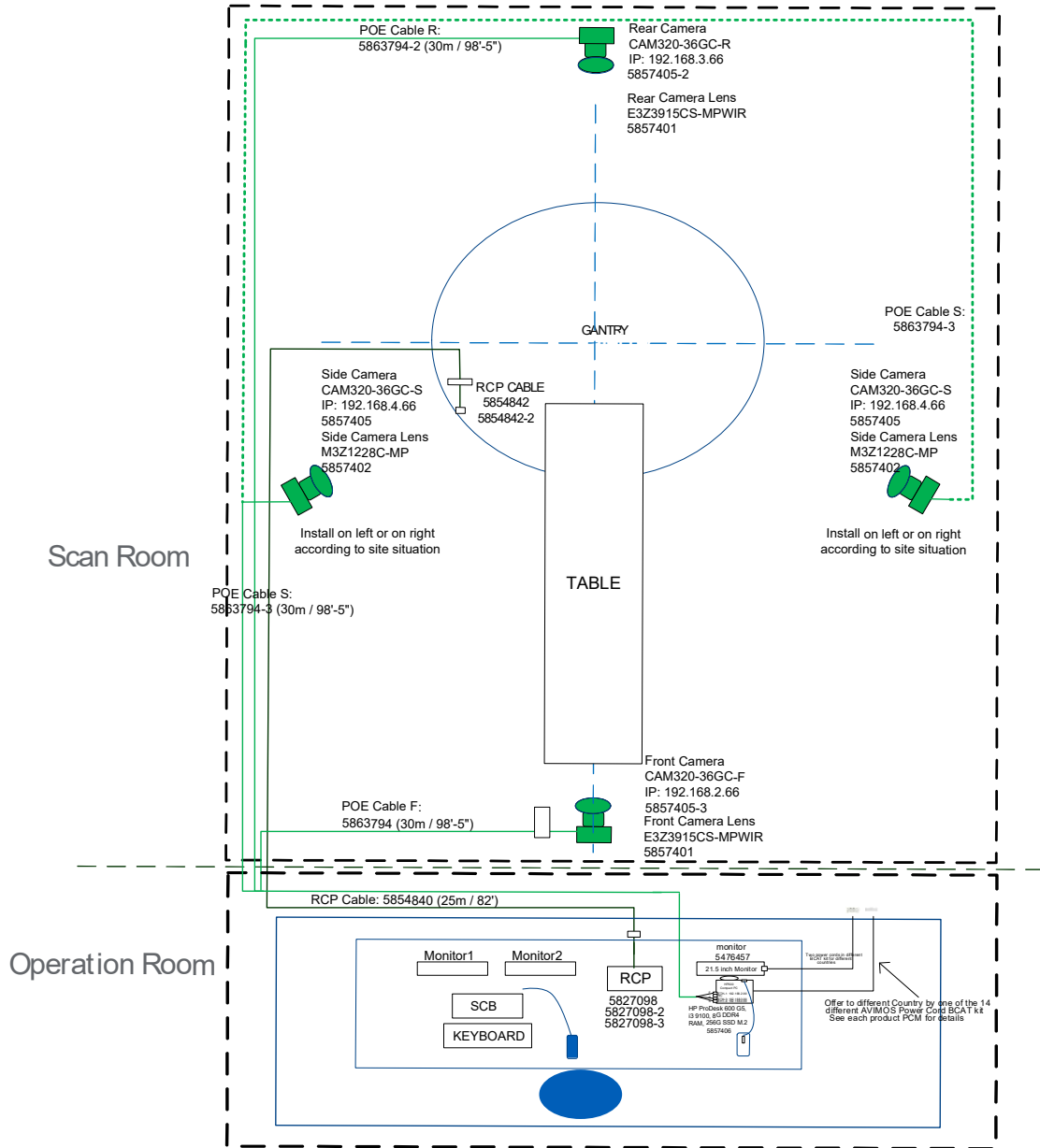
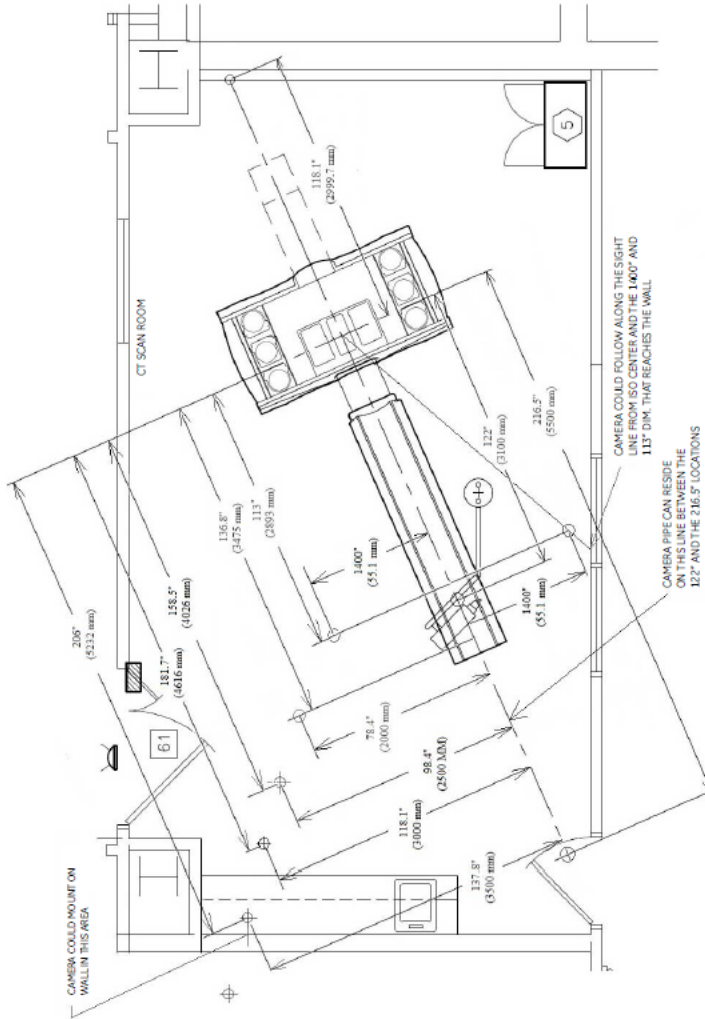

Figure 8-25 Example for Camera Position



Junction Plate Requirement

GE will provide two junction plates (Standard - 5863746 and Pipe - 5863748). If the junction plates supplied by GE can not meet the requests of the building structure, the customer’s architect can design and install the equivalent junction plate with sufficient strength to hold the camera.



The customer’s architect is responsible for installing of junction plate. The system manufacturer will NOT inspect and test that the fixing methods between the Junction Plate and the building structure meet the loading capacity specified (recommend a 4x safety factor).

Standard Junction Plate

Figure 8-26 Standard Junction Plate (Supplied by GE)

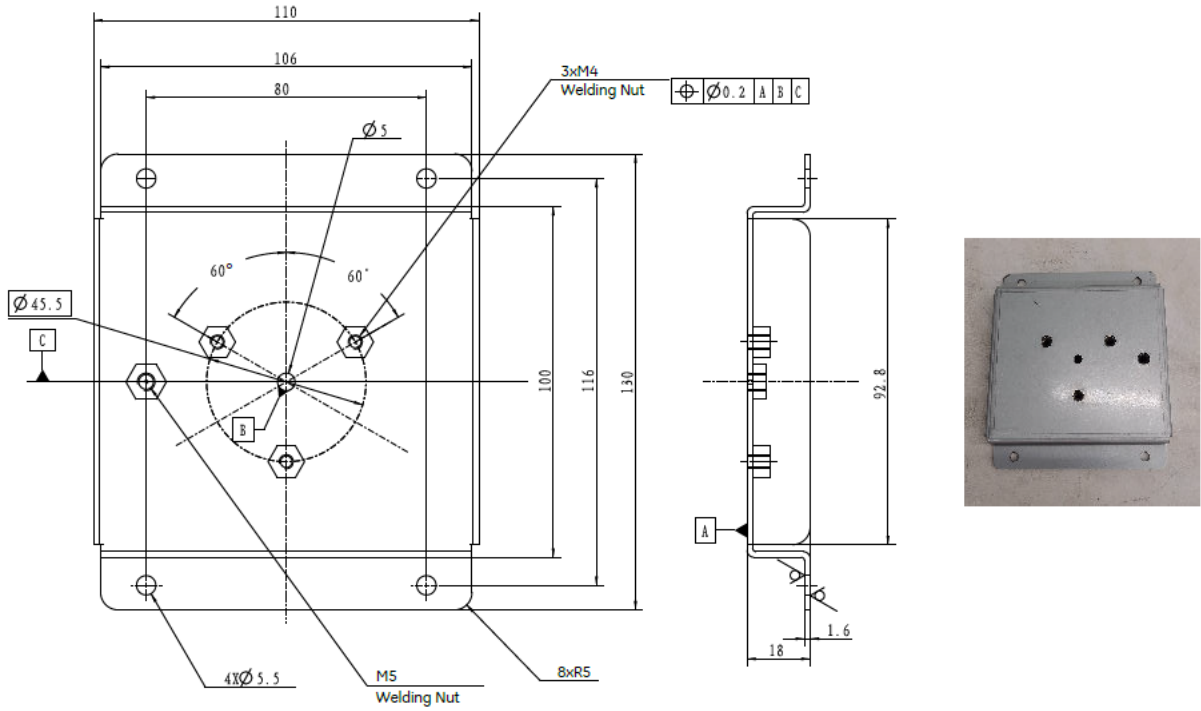
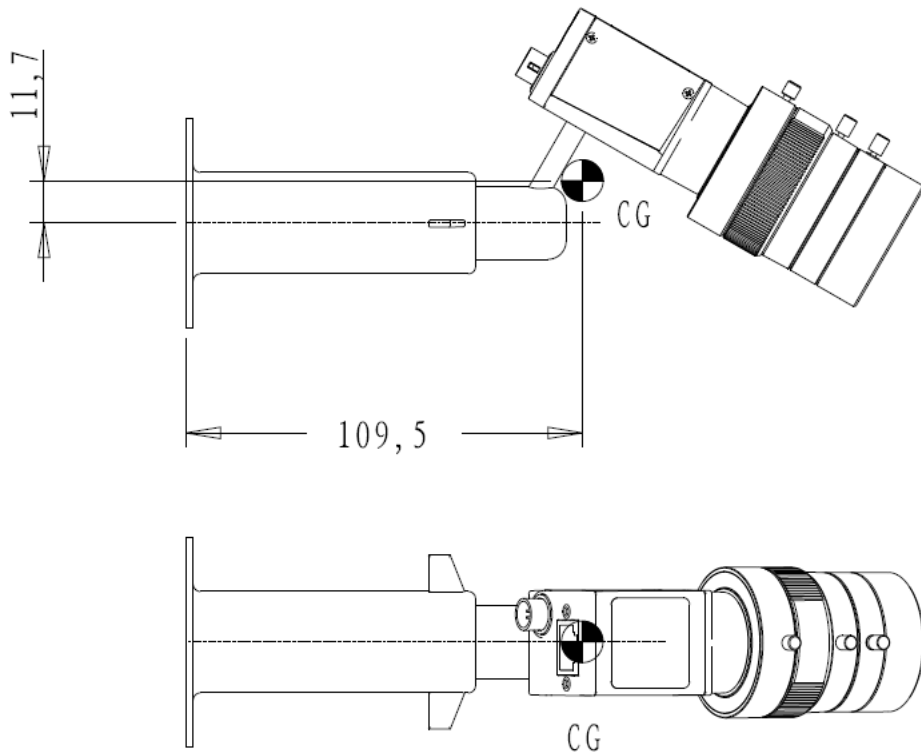

Figure 8-27 Center of Gravity



Center of Gravity for Standard Configuration



If a structural contractor designed an equivalent flat plate, the thickness should be 15mm or more, three (3) M4 mounting holes are required to anchor the camera bracket to the junction plate and one (1) M5 hole is used to anchor the safety chain. Please consider the loading capacity of the junction plate, the total weight of the camera and bracket provided by GE is 0.335kg.

The detailed instruction for hole size refers to [Figure 8-26 Standard Junction Plate \(Supplied by GE\) on page 81](#) and [Figure 8-27 Center of Gravity on page 81](#).

Junction Plate for Pipe

Figure 8-28 Junction Plate for Pipe (Supplied by GE)

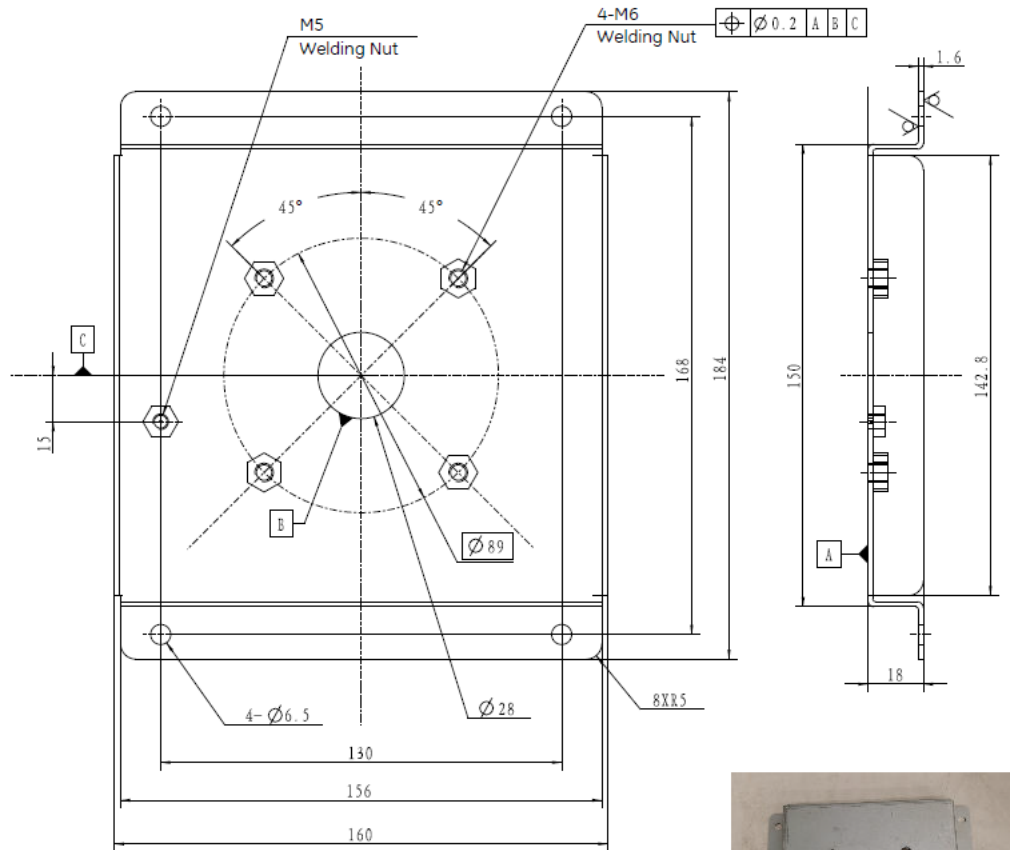

GB-T 13681-1992 Welding Nut		
	M5	M6
thickness (mm)	3.7 - 4	4.7 - 5
pledge load (N)	11000	15500

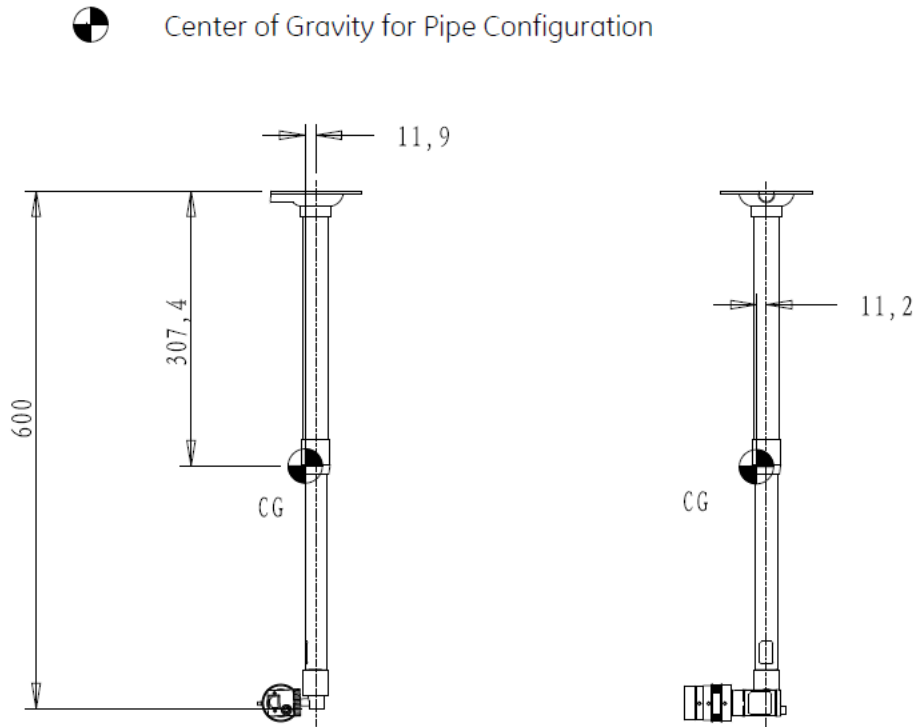

Figure 8-29 Center of Gravity

If a structural contractor designed an equivalent flat plate, the thickness should be 15mm or more, four (4) M6 mounting holes are required to anchor the camera bracket to the junction plate and one (1) M5 hole is used to anchor the safety chain. Please consider the loading capacity of the junction plate, the total weight of the camera and extendable pipe provided by GE is 0.665kg.

The detailed instruction for hole size refers to [Figure 8-28 Junction Plate for Pipe \(Supplied by GE\)](#) on page 82 and [Figure 8-29 Center of Gravity](#) on page 83.

Cable Requirement

Figure 8-30 Cable Connection

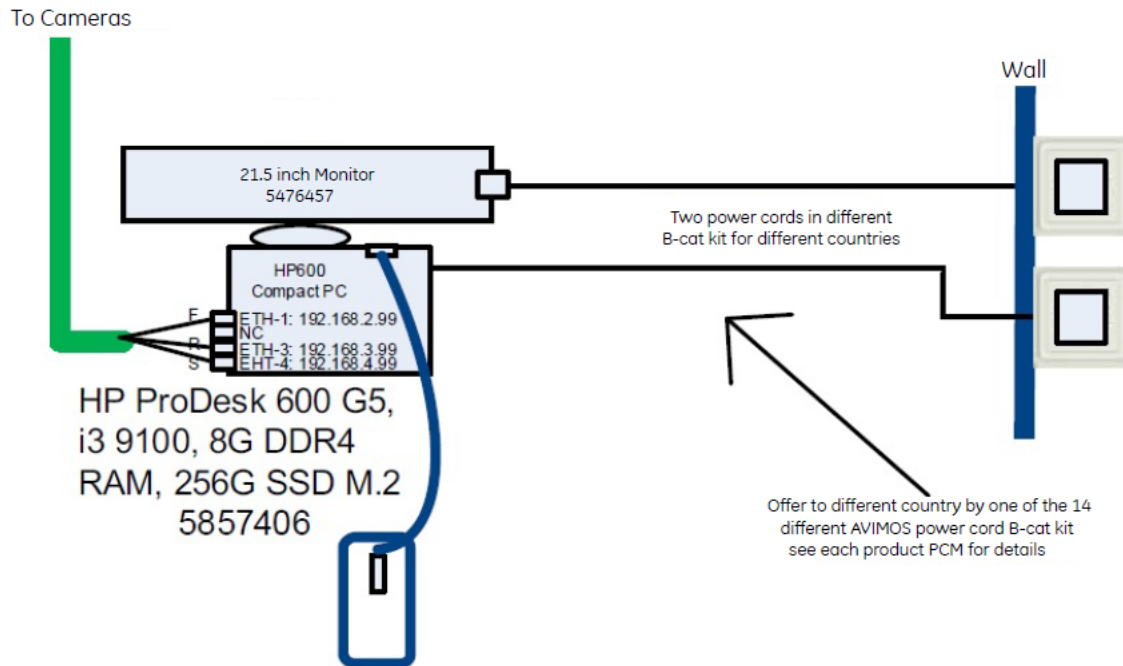

LAN Cable Requirement

RCK-AVIMOS has three LAN cables, which need to be routed from the operating room to the scan room, so the customer should complete cable-conduit installation on ceiling in advance. (Refer to [Figure 8-24 RCK-AVIMOS Schematics Diagram on page 79](#))

Power Cable Requirement

AVIMOS power cord should meet global all countries/regions, there are 14 selectable Power Cord Kits for different countries. (See [Figure 8-30 Cable Connection on page 84](#))



NOTE

The computer and monitor of AVIMOS needs to be placed in scan room because of cameras adjustment, please ensure that the wall output voltage in the scan room meets the requirements of the computer and LCD monitor.

Table 8-2 Computer and Monitor Voltage Requirement

Component	Element	Range
HP600 Computer	Mains input Volts / Amperes / Frequency	100-240VAC, ~/2.3A, 50-60Hz
LCD Monitor	Mains input Volts / Amperes / Frequency	100-240VAC, 0.75-0.40A (1.3A for Mexico), 50/60Hz

Minimum Floor Requirements

FLOOR LEVELNESS SPECIFICATIONS

Critical Specifications Accurate patient positioning during scanning depends on proper alignment of the gantry and the table. Based on the floor levelness specifications in the table below ensure that the table and gantry height adjusters have enough range to allow proper leveling of the system.

Table 8-3 CRITICAL SPECIFICATIONS: for floor levelness

Specification	Metric - minimum	English - minimum

Table 8-3 CRITICAL SPECIFICATIONS: for floor levelness (Table continued)

Levelness	6 mm maximum variance over 3048 mm	1/4 in maximum variance over 10 ft
-----------	------------------------------------	------------------------------------

Floor Levelness Guidelines Consider the following factors when determining floor levelness:

- Factors that can disturb the levelness of a weak floor, including:
 - Moving weights such as gurneys or heavy personal equipment.
 - Changes in the system's center-of-gravity when the table moves, as the table can carry a load capacity of up to GT2000X Table with 306kg (675lbs) / GT1700 and GT2000 Table with 227kg (500lbs).
- Resilient tile, carpeting, or equivalent that may yield or compress over time. At sites with such floor coverings, be sure to cut away the tile or carpeting where the table and gantry adjusters touch the floor to expose the stable base material upon which to seat the adjusters.
- Floor shims are NOT PERMITTED.
- Refer to the illustration below and steps in this chapter to check whether the floor of the scan suite meets the floor levelness specifications for the system.
- Refer to the illustration below and steps in this chapter to check whether the floor of the scan suite meets the floor levelness specifications for the system.

Measuring Floor Levelness



NOTE

The floor template (5111499-200) NOT shipped with system anymore, PMI needs order the floor template if needed.

1. Using the GE Floor template (p/n 5111499) to establish the room layout and system location, locate the table and gantry anchor holes.



NOTE

To order the GE floor template contact the GE Project Manager of Installation (PMI)

2. Place the gantry template on the floor and align it according to the GE site print.
3. Place the table template over the top of the gantry template, and align the scan and table centerlines.
4. Secure the templates to the floor.
5. Use a laser to check the levelness of the floor across the entire area covered by the template, as shown in the following Illustration.



NOTE

If the floor is not level, your system cannot be properly aligned.

Figure 8-31 Determining Floor Levelness

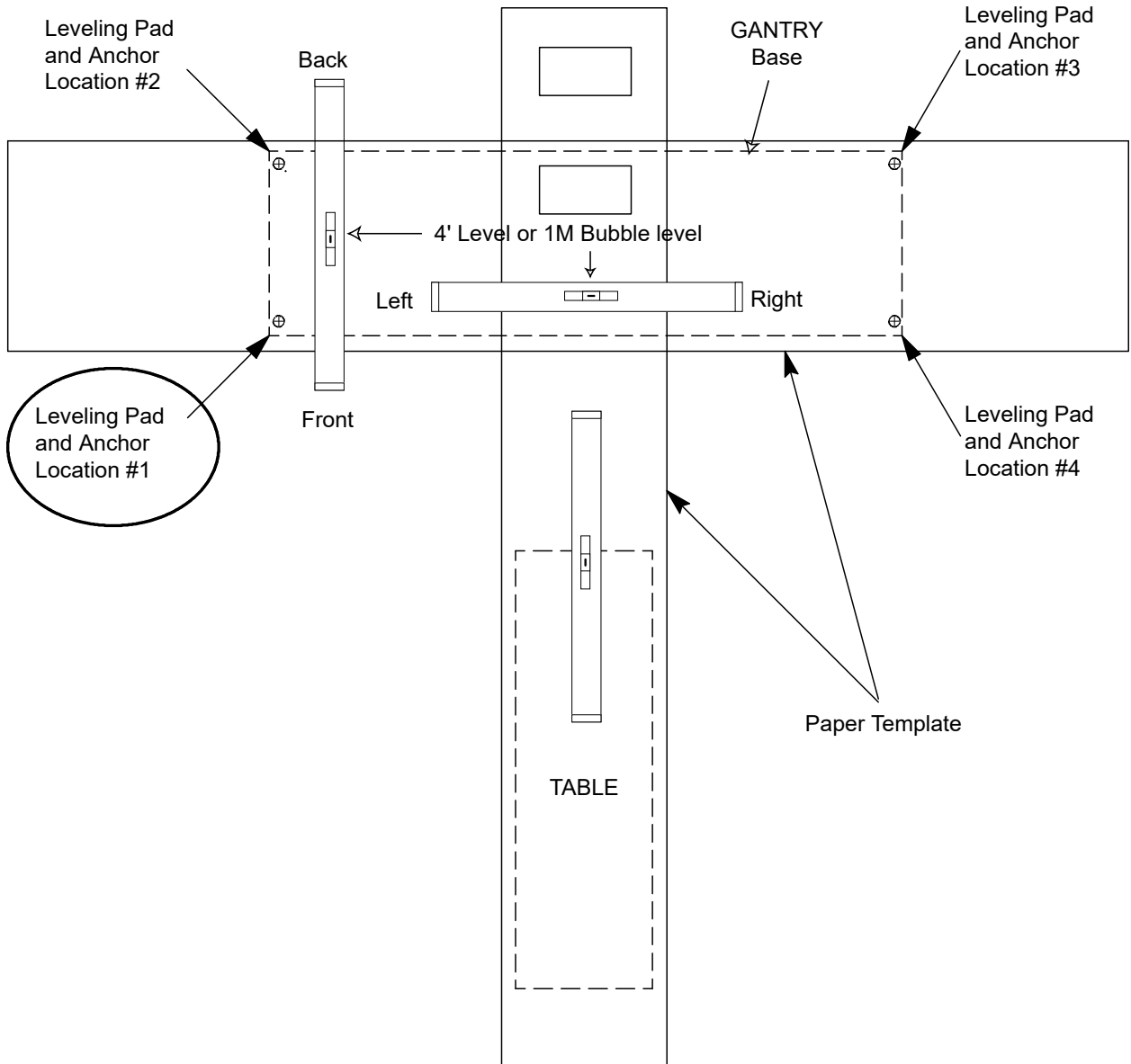

Gantry and Table anchor position refer to [Figure 8-32 Gantry and Table Anchor Position on page 87](#)

Figure 8-32 Gantry and Table Anchor Position

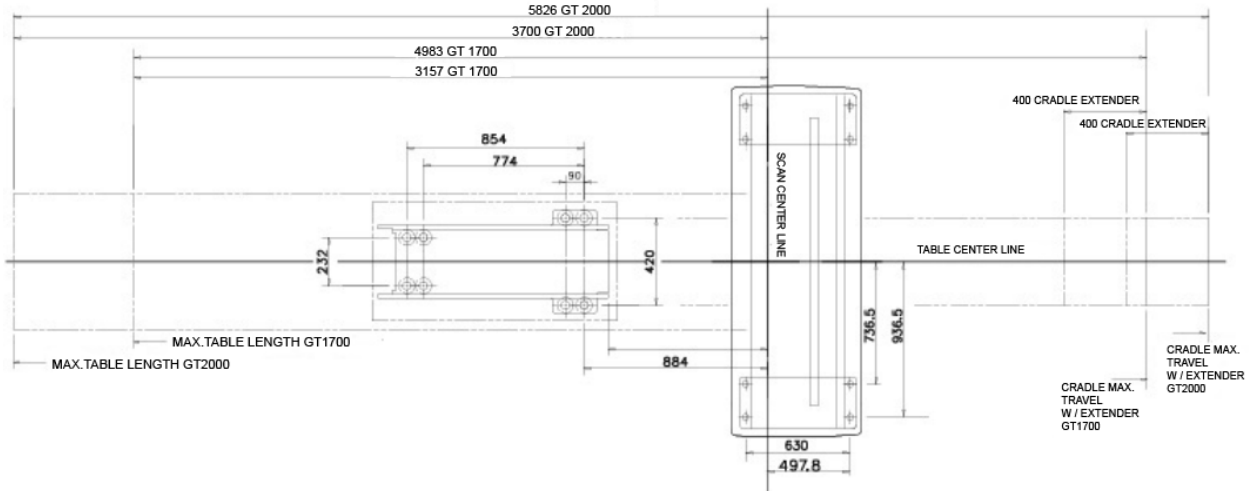

GE Site CAD Drawing with Alignment Tool (5824714)



NOTE

The alignment tool (5824714) NOT shipped with system, and also available from your PMI / FE from GE tool warehouse. Use this to determine equipment layout and anchoring locations.

1. Identify the position of the gantry and table in the room per the GE print. If everything matches the GE print, continue. If not, please redo two points M and N identification.

Figure 8-33 GE Print with GT Table

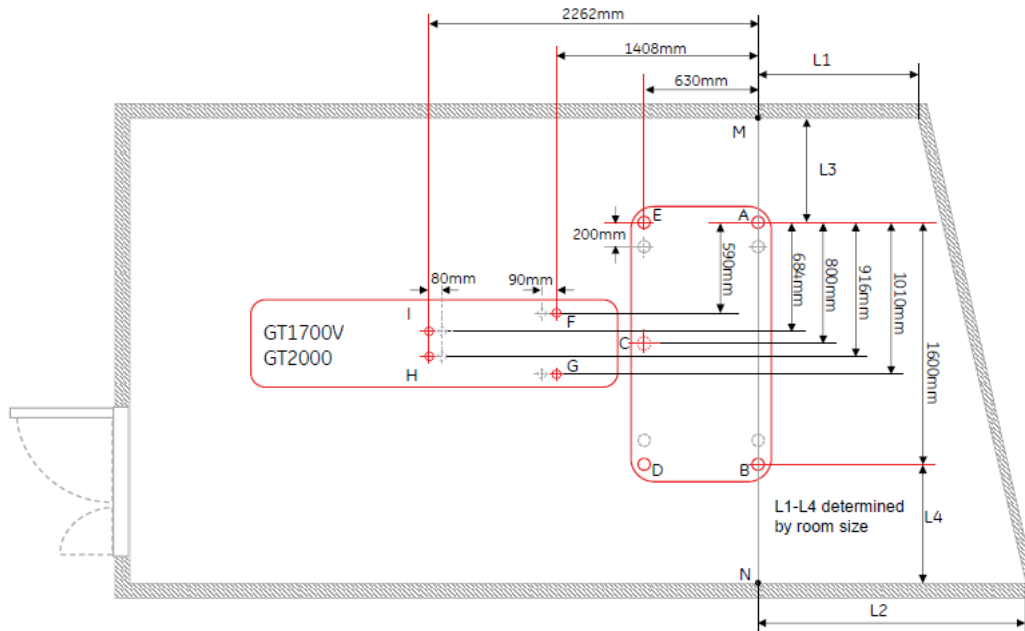

2. Make sure there are no potential clearance issues. If there are floor obstructions, such as conduits or old anchors, be sure to cut them flush to the floor to prevent the gantry from resting on them. Also, be sure there is at least 102 mm (4 in.) of clearance between any existing floor penetration and the new gantry position

- Place the bubble-level on the approximate position of the Gantry and Table to check the levelness of the floor across the entire area covered the Gantry and Table, as shown in

NOTE

If the floor is not level, your system cannot be properly aligned.

Figure 8-34 Check Floor Levelness

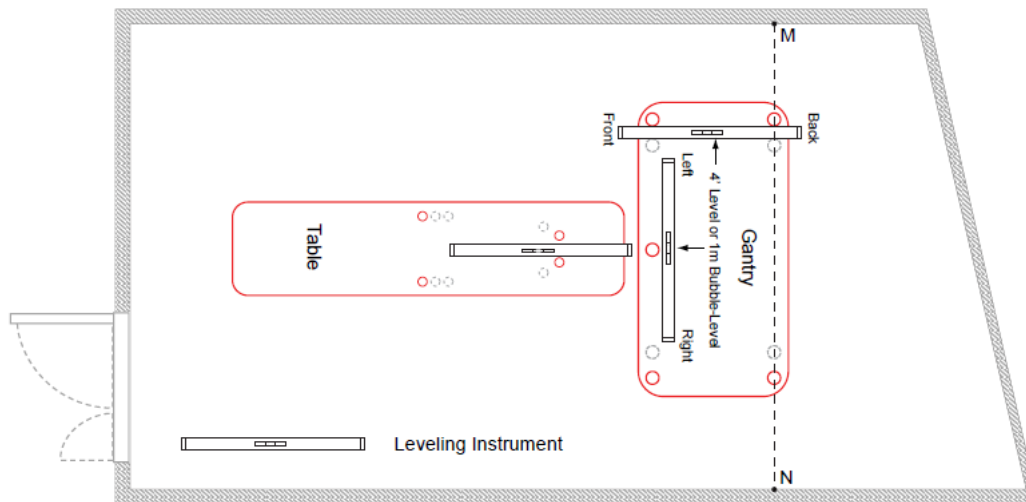
**FLOOR VIBRATION SPECIFICATIONS**

CT systems are sensitive to vibration and may display limited performance if exceeding the vibration limits listed below. The band of frequencies in which systems exhibit the most sensitivity appears at or near the resonant frequencies of the gantry and the patient table, the latter of which varies depending on the patient mass and location. These frequencies fall within the following ranges:

- Patient Table 2 - 10 Hz
- Gantry 8 - 14 Hz

Floor vibration from any intermittent or continuous source, such as walking, running, exercising, mechanical equipment, and traffic, must not exceed the levels shown in the illustrations below and represented by the solid line labeled *CT Scanner/Table*. These figures compare this limit to the limits of what the AISC (American Institute of Steel Construction) and the ISO (International Organization for Standardization) calls Class A (VC-A) and Class B (VC-B).

**NOTE**

In the illustration below the symbol μ represents 10^{-6} .

The preferred format for measuring vibration is velocity versus frequency. However, should it prove necessary to measure acceleration and there is no means to convert the measured data to velocity, then use the equivalent acceleration limit shown, derived from the velocity spectrum.

Figure 8-35 Allowable floor vibration in VELOCITY units compared to ISO class A & B limits

Frequency [Hz]	Velocity [$\mu\text{m/s}$, rms]
4	100
10	40
12.5	40
16	50
80	50

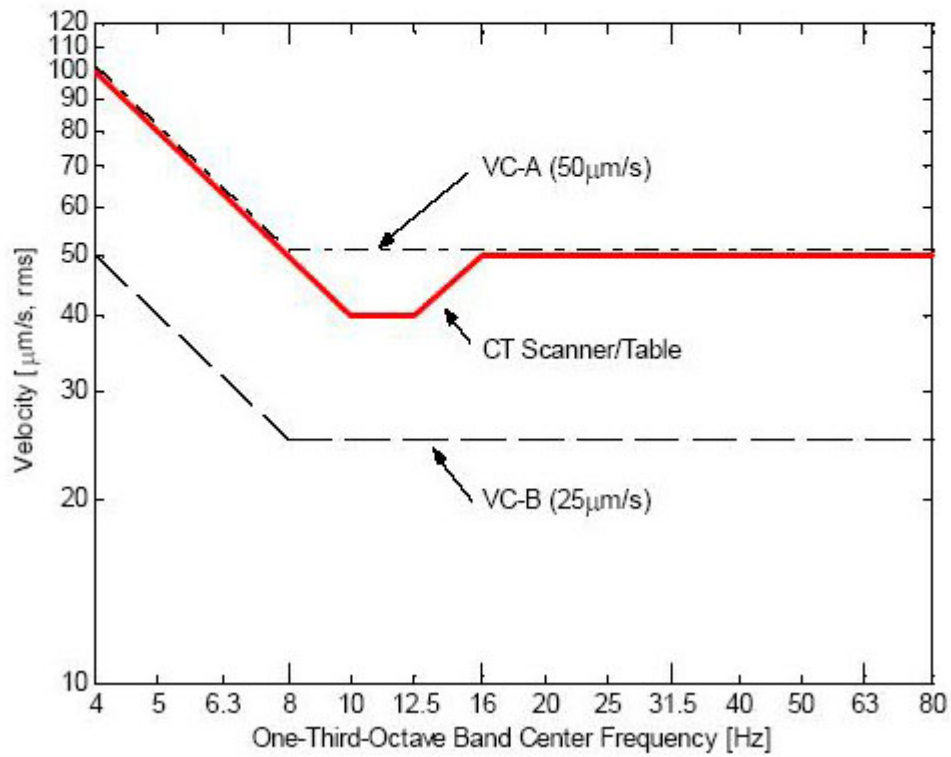
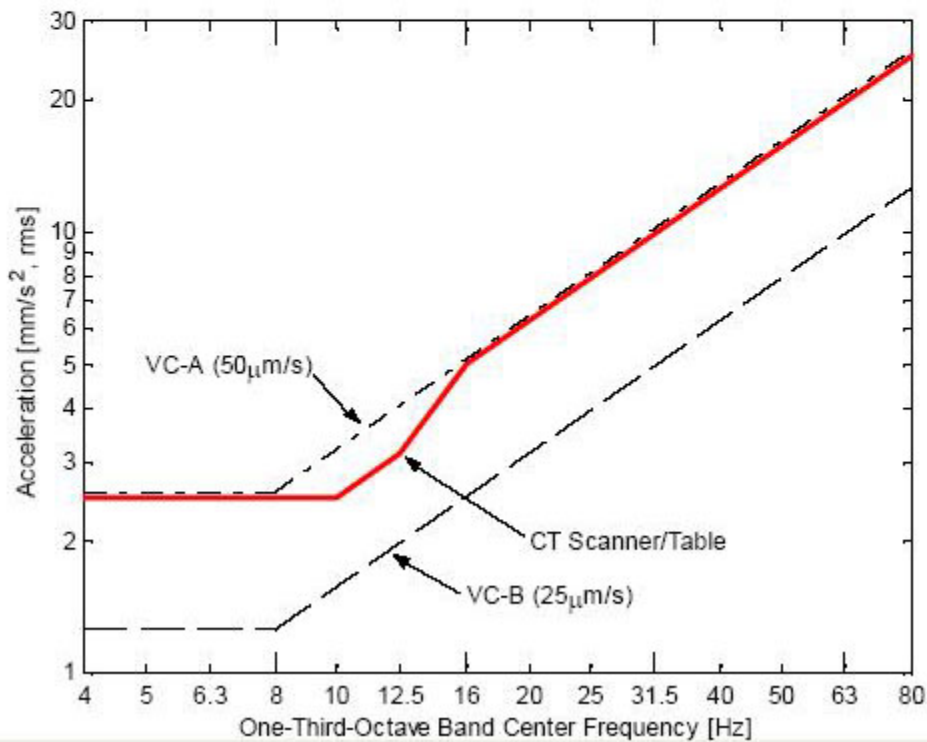

Figure 8-36 Allowable floor vibration in ACCELERATION units compared to ISO class A & B limits

Frequency [Hz]	Acceleration [mm/s ² , rms]
4	2.5
10	2.5
12.5	3.1
16	5
80	25



Sources of Floor Vibration Consider that vibrations strong enough to affect the floor may emanate from the following sources in and around the scanning facility, requiring possible isolation of the floor or structure from them:

- Hospital power plants housing pumps, motors, air handling equipment, or air conditioning units.
- Nearby rooms with exercise equipment or where running, jumping, or exercising occurs.
- Hallway foot traffic
- Elevators
- Parking Lots
- Roadways
- Subways
- Trains

- Helliports

Floor Strength

Concrete floors must have a minimum strength of $f'c = 2500$ psi (1.7×10^7 pa) at 28 days for (curing time) mounting floor anchors. It is the responsibility of each customer to have appropriate tests performed to determine and measure concrete strength.

WALLS

Scan Window The recommended patient viewing window dimensions are 1219 mm Wide X 1067 mm High (48 in X 42 in). The location of the window is dependent on the position of the operator work-space position. Consult chapter *Radiation Protection Requirements* and a **qualified radiological health physicist** for radiation protection requirements of the window glass (lead content and thickness).



NOTE

The operator, while at the operator work-space must be able to view the patient during a scan.

Finished walls inside the scan and control rooms must be painted at the time of installation. This requirement applies to all installation types. A finished wall exception is made for the following condition: In new construction, and upgraded facilities, a primer coat of paint is acceptable for equipment installation. However, the final coat of paint must be applied using a brush or some type (e.g. roller or bristle). The final coat of paint cannot be applied using a spray method.

Floor Loading and Component Weights

The customer's contractor and structural engineer should use the information in the table below to help determine if the floor structure in the scan suite possesses sufficient strength to support the weight of the system.

Table 8-4 Revolution Discovery CT Component Weight and Floor Loading Data

System Component	Net Weight	Overall Width X Depth	Maximum Uplift Load	Maximum Compressive Load	Supports
Gantry <i>with covers</i> (Discovery CT750 HD)	~1837 kg (~4050 lb)	2267 X 1007 mm (89.25 X 39.65 in)	0	4895 N (1100 lb)	Four round 64 mm (2.5 in) pads in rectangular pattern.
Gantry <i>with covers_LCD Panel</i> (Discovery CT and Revolution Discovery CT)	~1792 kg (~3950 lb)	2268 X 1028 mm (89.3 X 40.5 in)	0	4895 N (1100 lb)	Four round 64 mm (2.5 in) pads in rectangular pattern.
Dollies (each)	114 kg (250 lb)		0	4895 N (1100 lb)	
Gantry Top Cover (each) (Apply to all systems)	13 kg (29 lb)				
Gantry Side Cover (each) (Apply to all systems)	6.8 kg (15 lb)				
Gantry Front Cover (Discovery CT750 HD)	43 kg (95 lb)				

Table 8-4 Revolution Discovery CT Component Weight and Floor Loading Data (Table continued)

System Component	Net Weight	Overall Width X Depth	Maximum Uplift Load	Maximum Compressive Load	Supports
Gantry Front Cover_LCD Panel (Discovery CT and Revolution Discovery CT)	41.6 kg (92 lb)				
Gantry Rear Cover (Discovery CT750 HD)	45 kg (100 lb)				
Gantry Rear Cover_LCD Panel (Discovery CT and Revolution Discovery CT)	36.8 kg (81 lb)				
VT 1700 Table <i>without patient</i>	475 kg (1047 lb)	650 X 2436 mm (25.6 X 95.9 in)	2690 N (605 lb)	5350 N (1200 lb)	Four round 64 mm (2.5 in) pads
VT 1700 Table <i>with 227 kg (500 lb) patient</i>	702 kg (1547 lb)	650 X 2436 mm (25.6 X 95.9 in)	2690 N (605 lb)	5350 N (1200 lb)	Four round 64 mm (2.5 in) pads
VT 2000 / VT2000X Table <i>without patient</i>	505 kg (1113 lb)	650 X 2910 mm (25.6 X 114.5 in)	2630 N (591 lb)	5210 N (1170 lb)	Four round 64 mm (2.5 in) pads
VT 2000 Table <i>with 227 kg (500 lb) patient</i>	732 kg (1613 lb)	650 X 2910 mm (25.6 X 114.5 in)	2630 N (591 lb)	5210 N (1170 lb) ¹	Four round 64 mm (2.5 in) pads
VT 2000X Table <i>with 306 kg (675 lb) patient</i>	815 kg (1797 lb)	650 X 2910 mm (25.6 X 114.5 in)	2630 N (591 lb)	5210 N (1170 lb) ¹	Four round 64 mm (2.5 in) pads
Footswitch Assembly (VT)	15 kg (33 lb)				
Power Distribution Unit	~365 kg (~804 lb)	711 X 559 mm (28 X 22 in)	0	1070 N (240 lb)	Four casters
Console (GOC6.6)	238 kg (524 lb)	1238 X 1372 mm (49 X 29 in)	0	820 N (184 lb)	Four casters
Console (NIOHD64)	71.2 kg (157 lb)	470 X 738 mm (19 X 29 in)	0		
Open Console with Z840	65.1 kg (143 lb)	400 X 672 mm (16 X 26 in)	0		
Open Console with Z8G4	64.5 kg (142 lb)	400 X 672 mm (16 X 26 in)	0		
LCD Monitor (each)	10 kg (22 lb)				
Eaton UPS 9355	277 kg (610 lb)	305 X 850mm (12 X 33.5 in)	0	2157 N (485 lb)	Four casters
Smart Workspace Desk (SWS) 5449758-2	40 kg (88 lb)	1300 X 850 mm (51 X 33 in)			

Table 8-4 Revolution Discovery CT Component Weight and Floor Loading Data (Table continued)

System Component	Net Weight	Overall Width X Depth	Maximum Uplift Load	Maximum Compressive Load	Supports
¹ Note: Loads provided for table support with patient in worst-case-scenario positioning.					

Floor Loading and Anchoring Guidelines

- The table and gantry require secure anchoring to the scan room floor. The power distribution unit and the console sit on the floor with casters; anchoring of these components to the floor is optional, unless required because of seismic considerations.
- Anchors mount through the table and gantry supports. Use the floor template or its dimensions to locate the table and gantry support positions within the scan room, making sure that any anchors that pass through the supports clear all structural beams and interferences in the floor.
- If a loading analysis determines that the gantry and table position should change relative to their position on the GE site print, be sure to take into account the clearance requirements when determining an appropriate location for the scanner.
- Hospitals and scanning facilities throughout the world may utilize a variety of floor types, and the disposition of different floor types may necessitate additional planning to adequately accommodate the scanner.

Wood floors often require substantial reinforcement. GE does not recommend using wood floors.

Temperature variation in blacktop or marble floors may allow anchor movement and pullout. GE does not recommend using blacktop or marble floors.

GE recommends using concrete floors with a minimum thickness of 102 mm (4 in) when using GE supplied anchoring or any other equivalent anchoring method.

Anchor Edge Distance Definition

The edge distance of Table/Gantry floor anchor must have a minimum tension strength.

- **GT1700/GT2000/Gantry:** Using Hilti KBIII 0.5inch DIA*7 inch long anchor (P/N: 5487992-2/5874830-2)

The distance from CL of anchor to the edge of concrete basement of table and Gantry should not be less than 178mm, which is necessary to keep anchor full tension strength fRN.

- **GT2000X Table:** Using Hilti KBIII 0.5inch DIA*8 inch long anchor (P/N: 2106573)

The distance from CL of anchor to the edge of concrete basement of table and Gantry should not be less than 203mm, which is necessary to keep anchor full tension strength fRN.

NOTICE

Responsibility for providing an approved support structure and mounting method for all floor types other than the GE recommended floor rests with the purchaser. General Electric accepts no responsibility for any failure of the support structure or anchoring method, including those used for seismic mounting. GE accepts no responsibility for methods other than those listed.

GE Supplied Anchoring

GE supplies anchors for mounting the table and gantry. The console and power distribution unit do not require anchoring to the floor. It is the responsibility of the customer to have a structural engineer and trained contractor use either the GE supplied anchoring method or to provide an equivalent anchoring method to mount the table and gantry to the floor. Consult your architect, structural engineer, contractor, or PMI to resolve any questions.

⚠ WARNING



POTENTIAL FOR PATIENT INJURY!

AN IMPROPERLY SECURED SYSTEM WILL CAUSE DAMAGE OR PERSONAL INJURY.

SYSTEM CAN MOVE OR TIP DURING OPERATION IF NOT PROPERLY SECURED.

PATIENT SAFETY DURING SYSTEM OPERATION REQUIRES PROPER ANCHORING OF THE SYSTEM.

[GE Supplied Anchors on page 94](#) lists the specifications of GE-supplied anchors for the system. There are three types of anchors used in this product depending on manufacturing date. For a detailed view, including dimensions and additional specifications, see the following figures.

Table 8-5 GE Supplied Anchors

Part Number	2106573	5487992-2/5874830-2
Description	Hilti Kwik Bolt II	Hilti Kwik Bolt III
Diameter	12.7 mm (0.5 in)	12.7 mm (0.5 in)
Length	203 mm (8 in)	178 mm (7 in)

Figure 8-37 Gantry and Table Anchoring Diagram with 2106573 (8 in.) Anchor Bolt

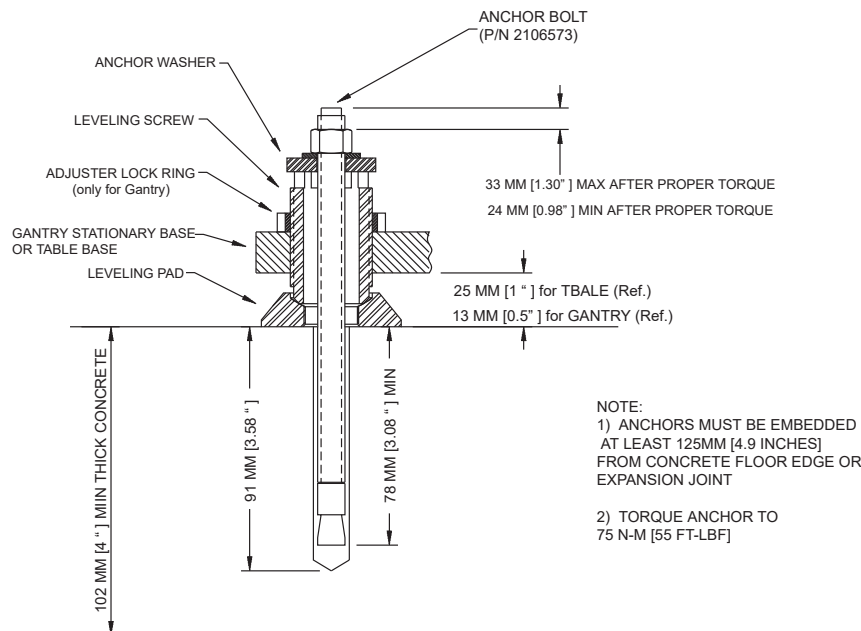
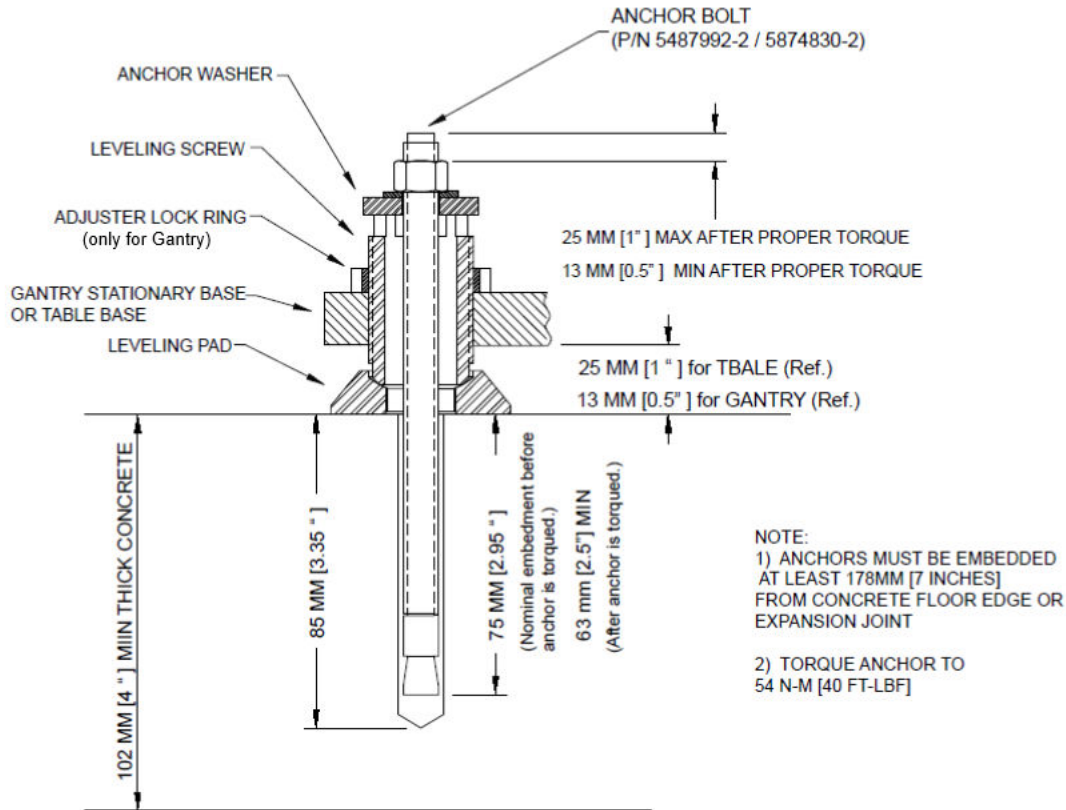

Figure 8-38 Gantry and Table Anchoring Diagram with 5487992-2/5874830-2 (7 in.) Anchor Bolt



Requirements for using GE Supplied Anchors

Use the GE supplied anchors ONLY when mounting components on concrete floors.

Adhere to all anchoring requirements listed in Table 4 below.

Any anchors showing more than 21 mm (~0.9 in) of thread above the torqued nut requires the installation of a second anchor in the closest adjacent mounting location. The second anchor shall meet the same requirements.

Non-seismic installation must use a minimum of four (4) anchors to mount the gantry and four (4) anchors to mount the table.

Fully engage the Adjuster Lock Rings (p/n 2106207) with at least one full thread showing below the notched portion on the Adjuster screw.



NOTE

The CT table does not have the Adjuster Lock Rings shown in [Figure 8-37 Gantry and Table Anchoring Diagram with 2106573 \(8 in.\) Anchor Bolt on page 94](#) and [Figure 8-38 Gantry and Table Anchoring Diagram with 5487992-2/5874830-2 \(7 in.\) Anchor Bolt on page 95](#) of this section.

Table 8-6 Table and Gantry Anchoring Requirements

Mounting Requirements	Anchor P/N 2106573	Anchor P/N 5487992-2/5874830-2
Minimum Floor Thickness	102 mm (4 in)	102 mm (4 in)
Recommended Drilling Depth	91 mm (3.58 in)	85 mm (3.35 in)

Table 8-6 Table and Gantry Anchoring Requirements (Table continued)

Mounting Requirements	Anchor P/N 2106573	Anchor P/N 5487992-2/5874830-2
Minimum Anchor Embedment	78 mm (3.07 in)	75 mm (2.95 in)
Available Alternate Anchor Locations	Yes	Yes
Shipped Anchor Size	203 mm (8 in)	178 mm (7 in)
Alternate Anchoring Methods	Yes, see notes below.	Yes, see notes below.
Floor Levelness	6 mm (0.25 in) maximum variance over 3048 mm (10 ft)	6 mm (0.25 in) maximum variance over 3048 mm (10 ft)

Seismic Mounting

Refer to the sections in this section when mounting the system in seismic zones.

Responsibility for proper seismic mounting rests with the customer. Refer to all applicable laws and codes for your locality.

Seismic angle brackets are included with the PDU and console for sites requiring seismic anchoring of these units.

GE supplied anchors may not meet local seismic laws and codes. Use them only if a qualified structural engineer approves them for use in local seismic applications.

The customer's contractor often supplies a state certified print or equivalent, showing seismic installation instructions.

Consider seismic requirements for ceiling mounted fixtures and refer to the appropriate installation instructions for ceiling mounted fixtures.

(For PDU) PDU seismic brackets (2354563-2) and the PDU shipping kit (5453382-2) are shipped with the PDU. Detail bracket Installation procedure refer to Installation Manual.

Figure 8-39 PDU Anti Seismic Brackets (2354563-2)

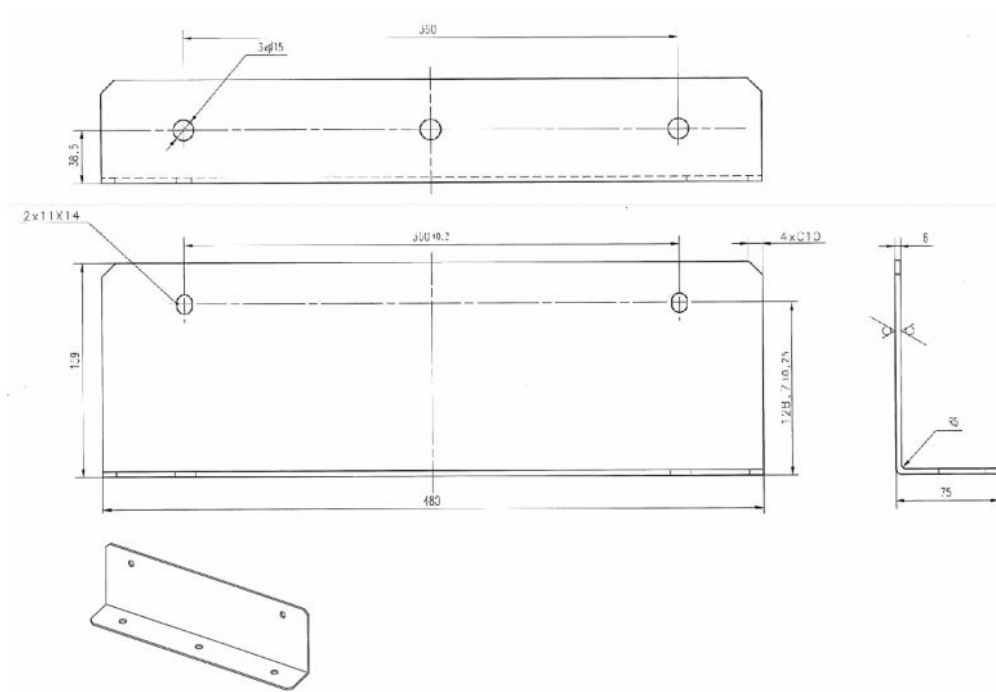

(For Console) Console seismic brackets and screws are included in Console Seismic Kit (5812703-2) that are shipped with Console.

Figure 8-40 Console Anti Seismic Brackets (5357148-3)

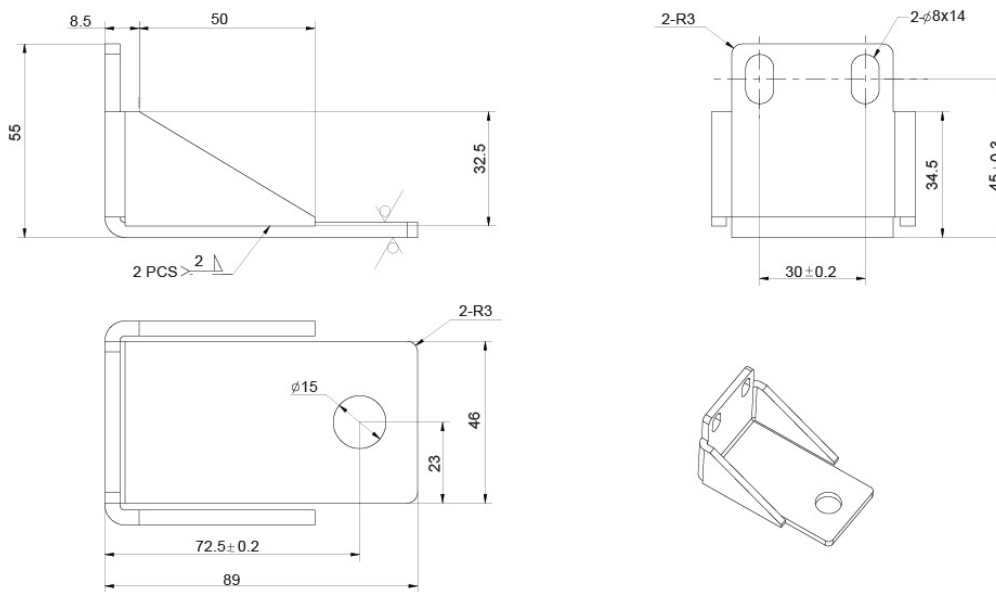

CENTER-OF-GRAVITY Information

The information in the following illustrations provides the customer’s contractor and/or structural engineer with center-of-gravity information to assist in seismic calculations for the system.

Figure 8-41 Seismic Anchoring Specifications and Center-of-Gravity for PDU

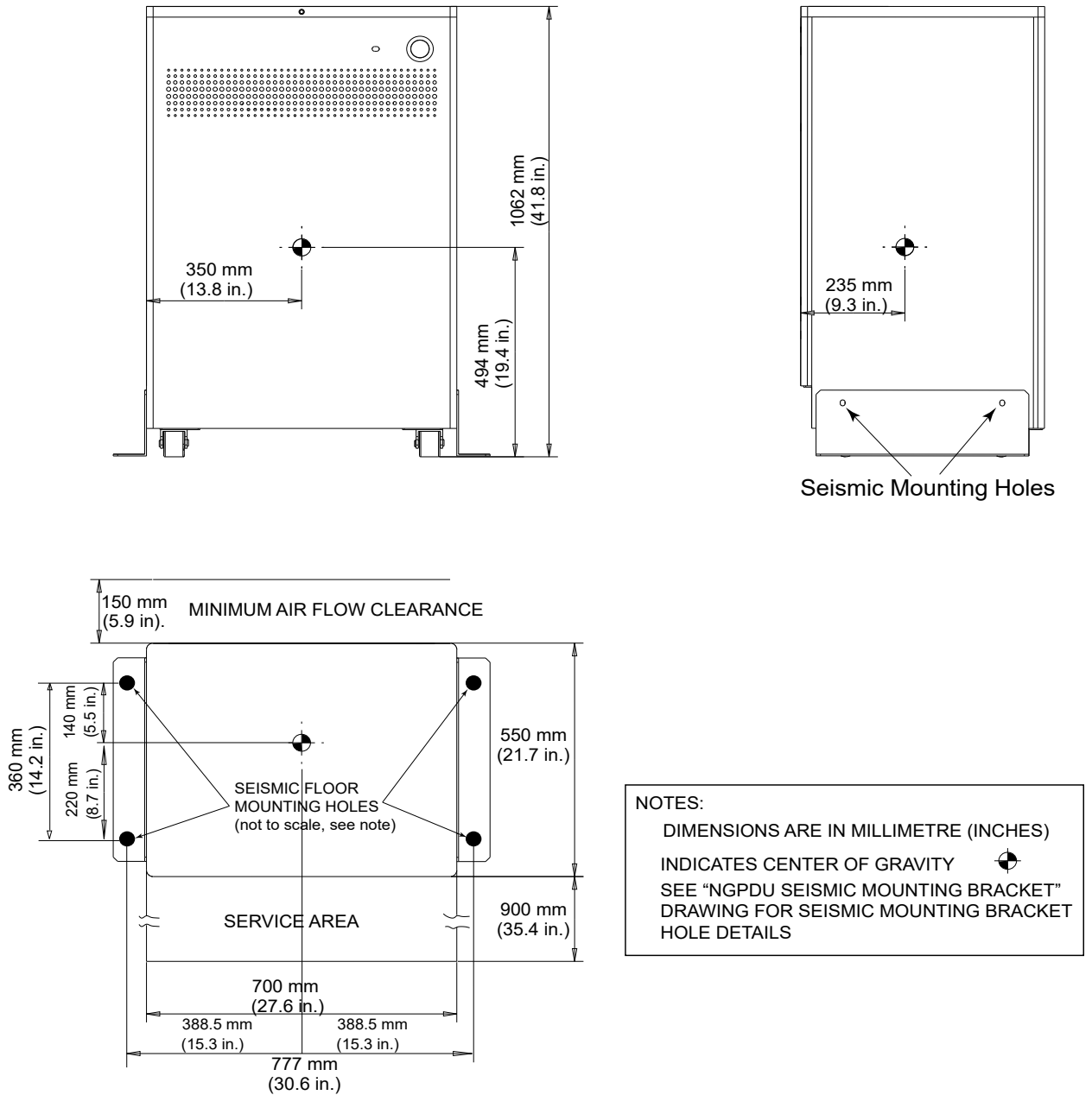

Figure 8-42 GOC6.X Console Center-of-Gravity

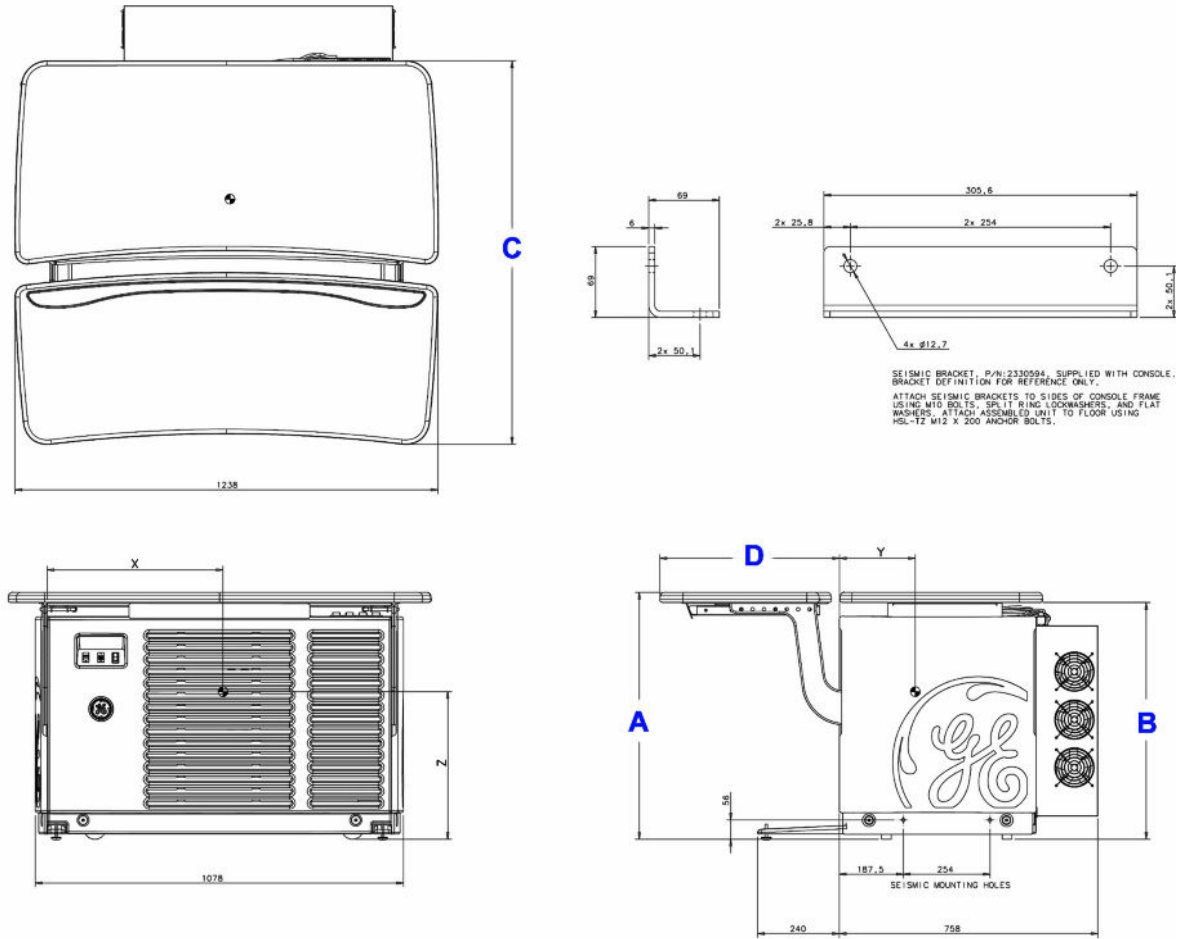

Figure 8-43 NIOHD64 Console Center-of-Gravity

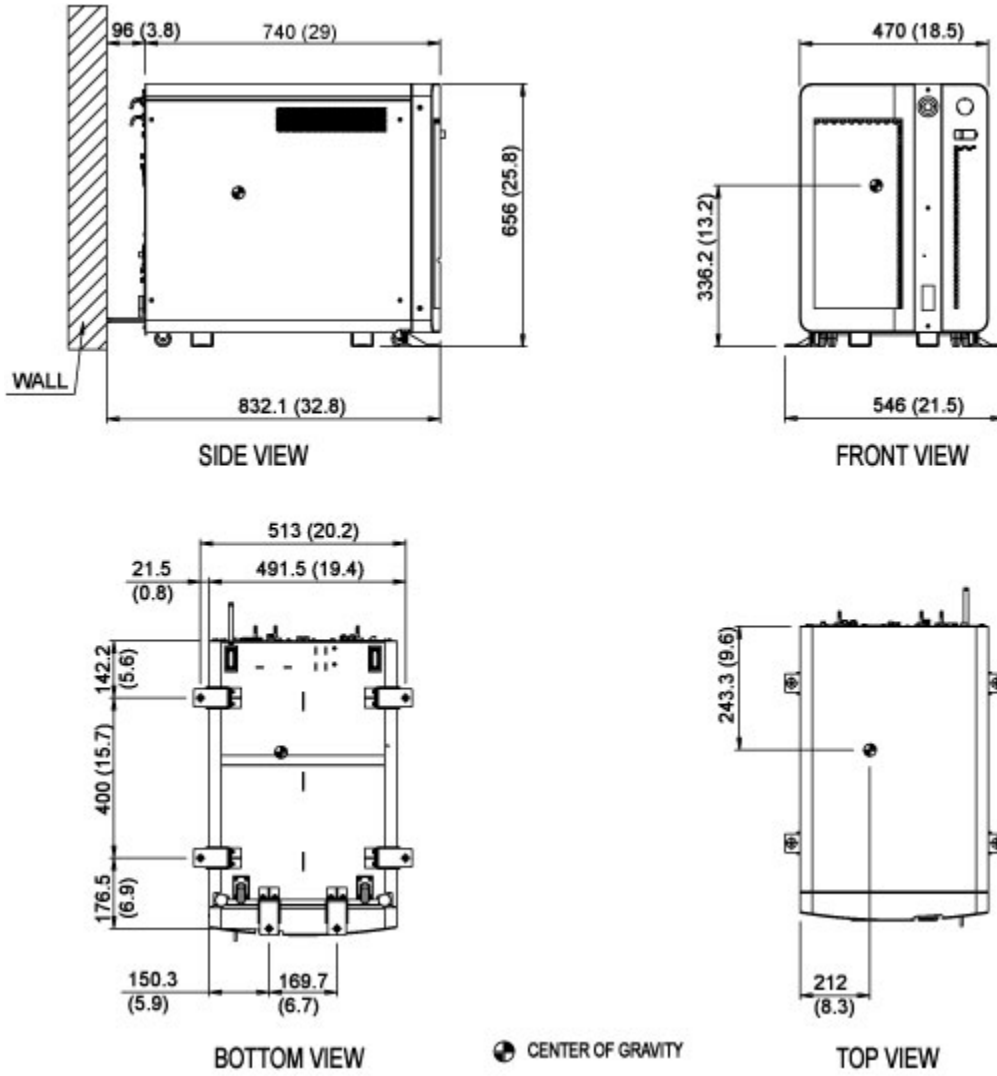

Figure 8-44 Seismic bracket and Open Console (Z840) Center-of-Gravity

Unit: mm (in)

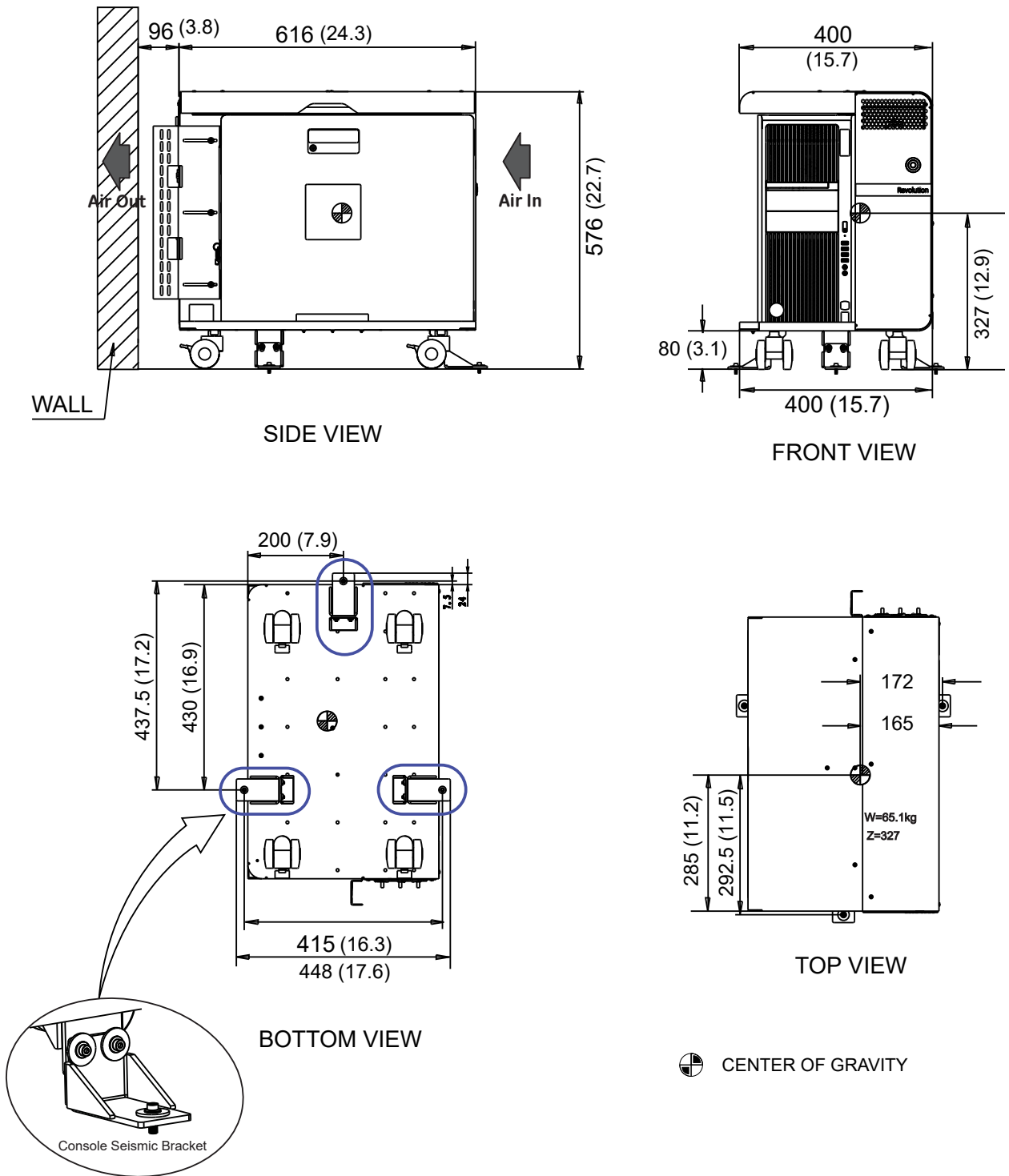
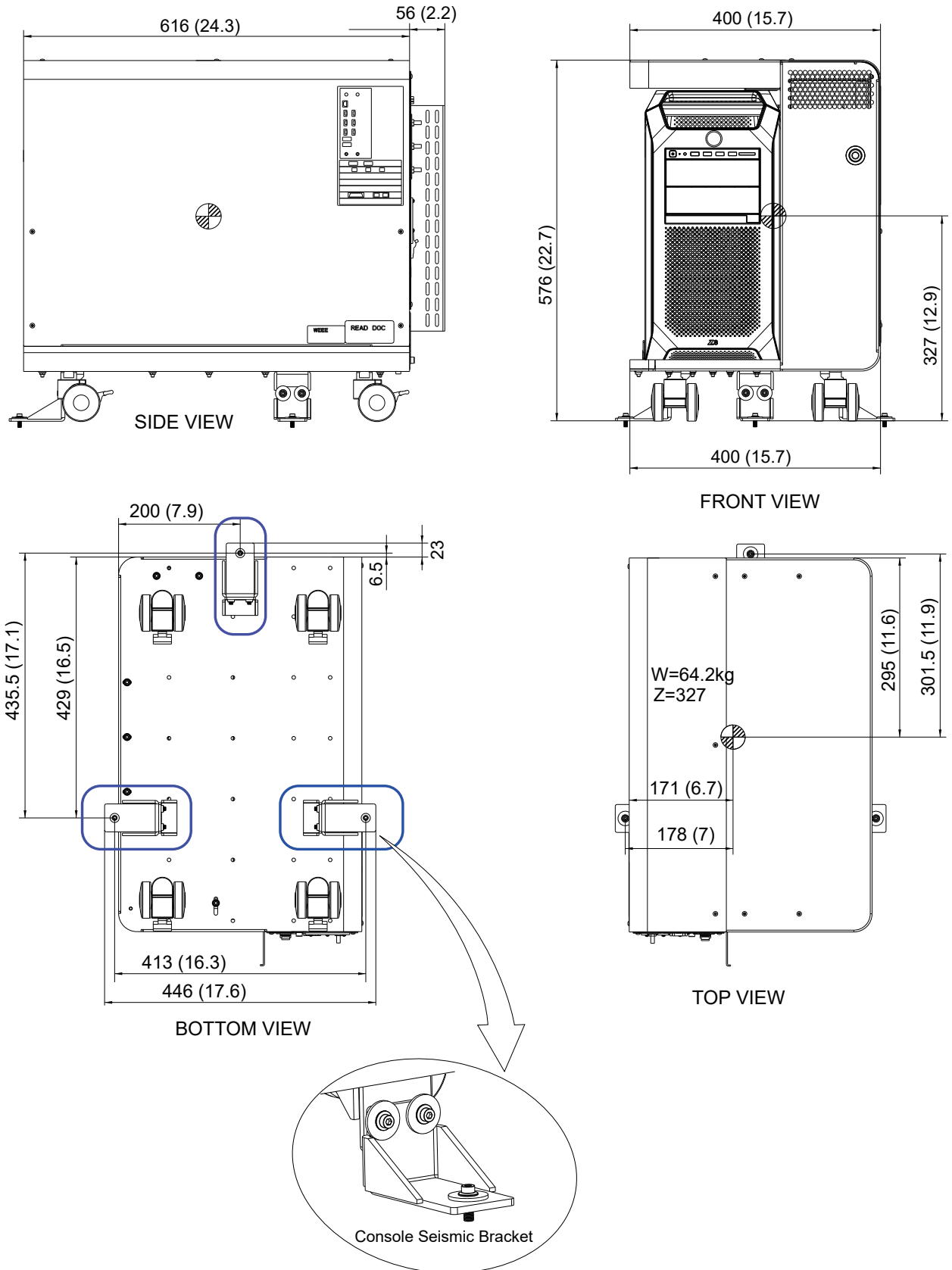

Figure 8-45 Seismic bracket and Open Console (Z8G4) Center-of-Gravity





NOTE

The Front cover shown in [Figure 8-46 Gantry Center-of-Gravity - Discovery CT750 HD](#) on page 103 is applied to Discovery CT750 HD Gantry, which is equipped with LED display panel.

The Front cover shown in [Figure 8-47 Center-of-Gravity Gantry with LCD Panel - Revolution Discovery CT and Discover CT](#) on page 103 is applied to Discover CT and Revolution Discovery CT, which are equipped with LCD display panel.

Figure 8-46 Gantry Center-of-Gravity - Discovery CT750 HD

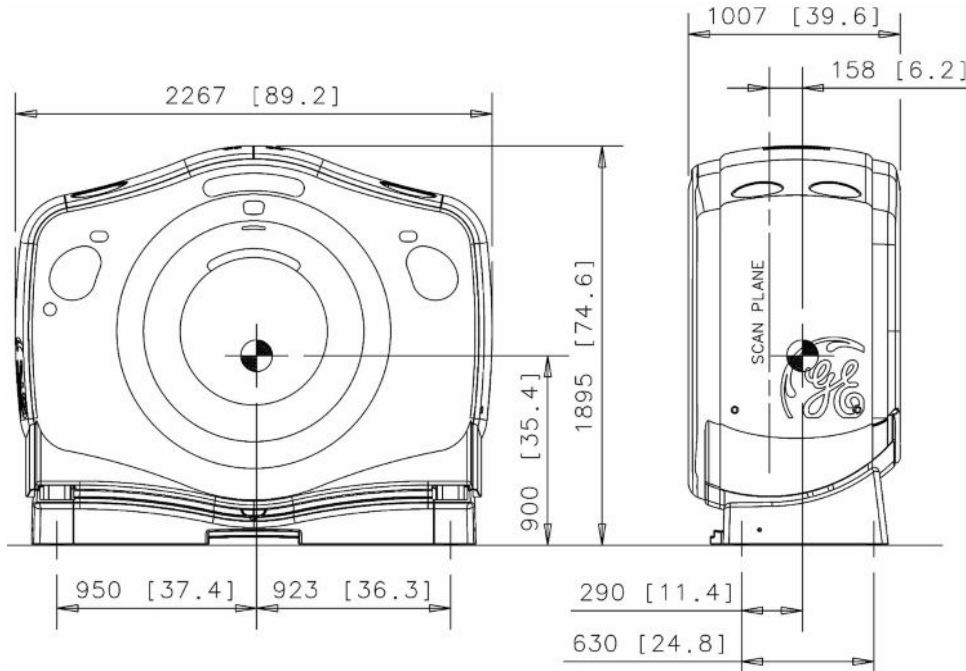

Figure 8-47 Center-of-Gravity Gantry with LCD Panel - Revolution Discovery CT and Discover CT

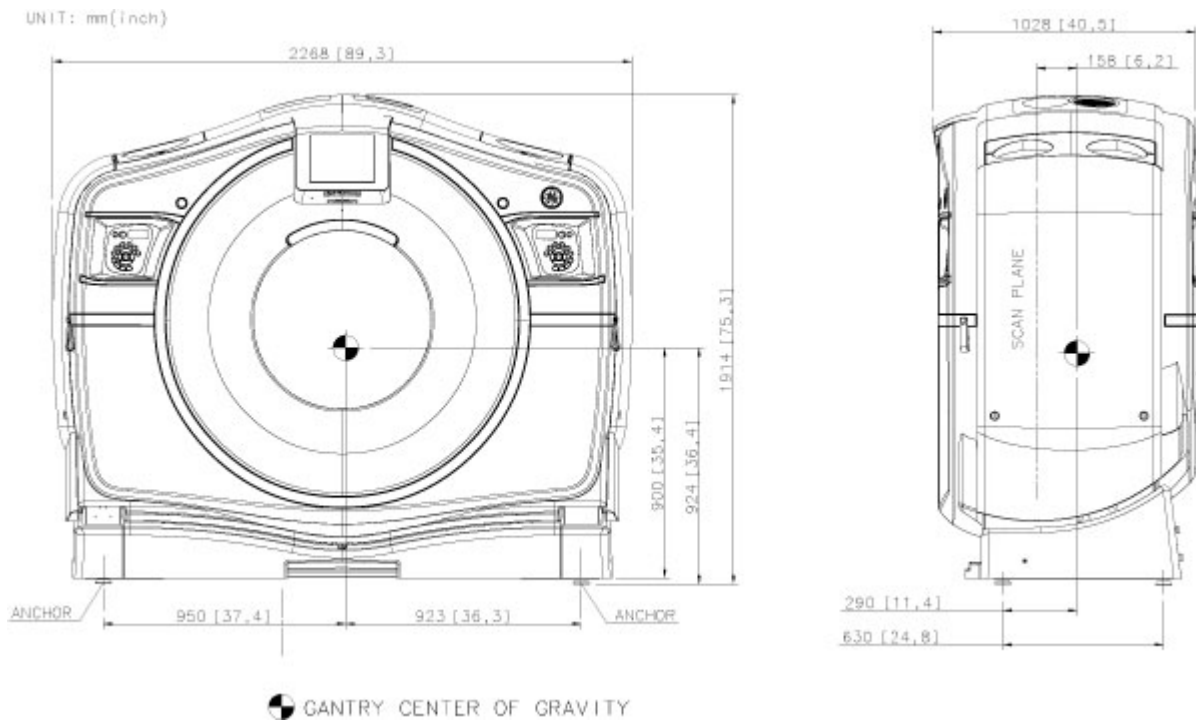
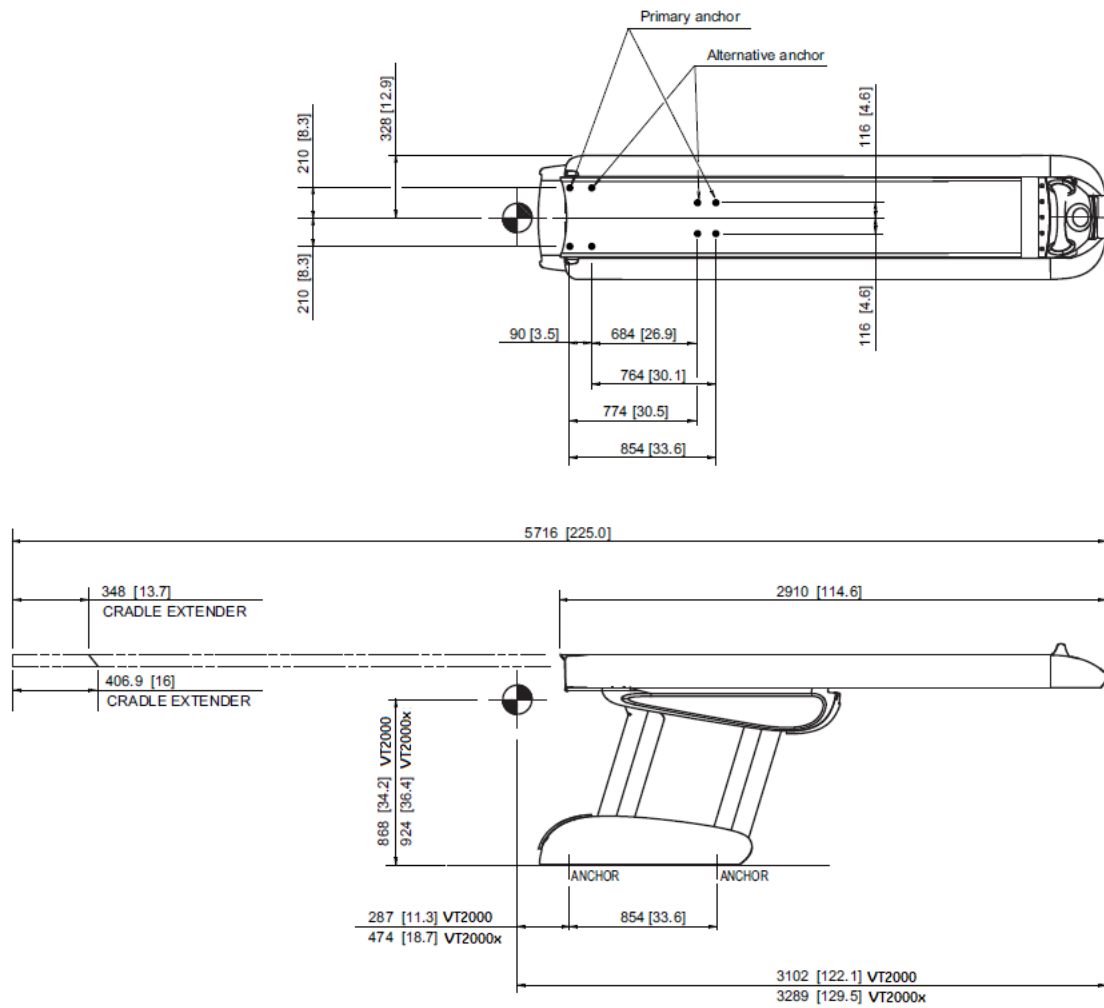

Figure 8-48 GT 2000/ GT2000x Table Center-of-Gravity



NOTE

Center of Gravity location marked above includes the mass of a maximum 227kg (500lb) load capacity for GT2000 and 306kg (675lb) load capacity for GT2000x on the table with a fully extended cradle.

Figure 8-49 GT1700 Table Center-of-Gravity

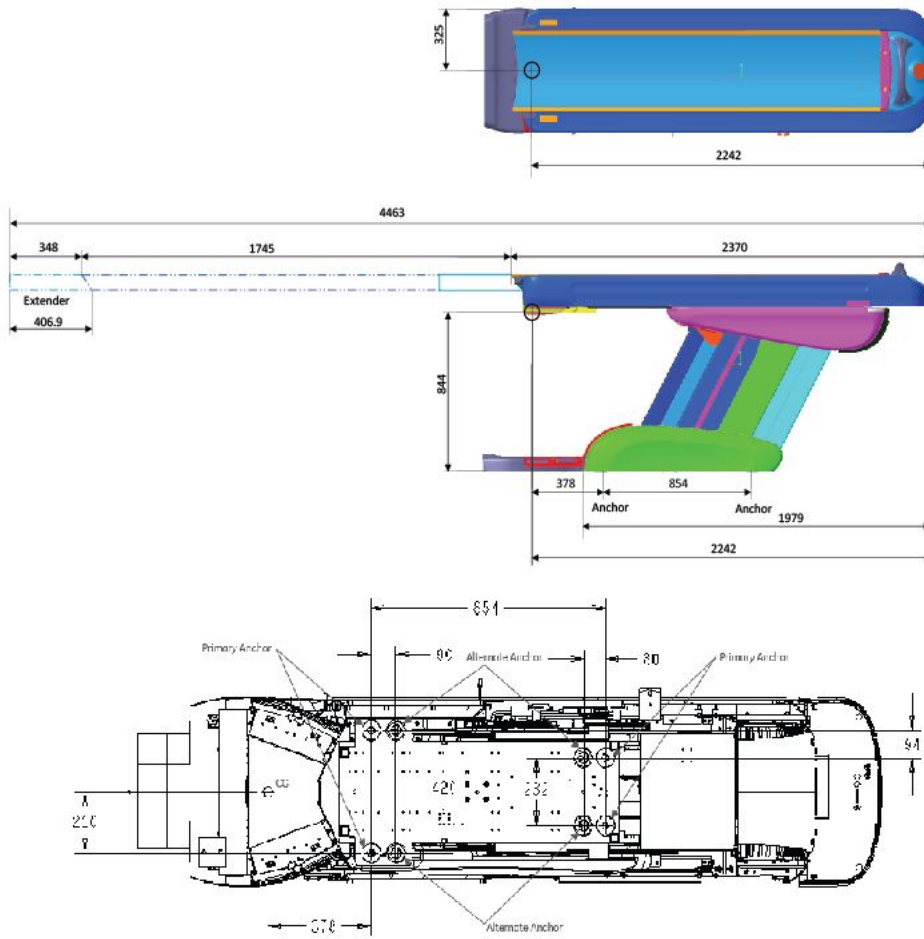

Note: Center of Gravity location marked above includes the mass of a maximum 227kg load capacity on the table with a fully extended cradle.

Page intentionally left blank

Chapter 9 Environmental Requirements

9.1 Environmental Requirements

Ensure the operational readiness and proper system calibration of HVAC prior to installation. Maintain the environmental conditions listed below at ALL times, including overnights, weekends, and holidays. Shut down the CT system if air conditioning is not working. When shutting down the system for major repair, you may also shut down the air conditioning.

Environmental specifications apply to the table, gantry, power distribution unit and operator console.

NOTICE

Exceeding environmental specifications may adversely affect system operation and image quality.

Temperature and Humidity Specifications

Accurate determination of hospital room environmental conditions may require the temporary installation of a temperature and humidity recorder near the location designated for the system installation. Record temperature and humidity readings before and after installation to verify the site's true environmental conditions.

Consider heating, ventilating, air conditioning (HVAC) needs, and redundancy (back-up). An air conditioner with two compressor units rather than one, may prevent system downtime. A redundant (back-up) air conditioner permits CT system operation during an extended repair of the primary air conditioner.

Temperature (Scan and Control Rooms)

System Temperature Limits	
Maximum allowable ambient room temperature:	26° C (79° F)
Recommended ambient room temperature:	22° C (72° F)
Minimum allowable ambient room temperature:	18° C (64° F)
Equipment Room (Optional room where the PDU may be located instead of scan room)	18-26° C (64-79° F)



NOTE

Be certain to account for ANY cooling equipment cycle control range, ensuring that the maximum and minimum ambient room temperatures do not exceed those shown here during room thermal cycling. For example, if the HVAC is capable of $\pm 2^{\circ}$ C control, then the limits would be 20°-24° C to maintain absolute limits.

Humidity (Scan and Control Rooms)

System Humidity Limits	
Maximum allowable non-condensing relative humidity:	60%
Minimum allowable non-condensing relative humidity:	30%

Cooling Requirements

This table is to assist in cooling requirements planning. Gantry operation requires over half of the cooling utilized by your scanner. Contact an HVAC specialist to determine optimal placement of the thermostat and all HVAC vents, bearing in mind that:

- Gantry air INTAKE occurs across the BOTTOM of the gantry.
- Gantry air EXHAIST occurs across the TOP of the gantry.

SYSTEM with GOC6.6 Console HEAT OUTPUT		
System Component	Maximum BTU/HR	Maximum WATT
Typical Scan Room Subtotal Includes: gantry, table, PDU, and peripherals	35,000	10,248
Non Typical Scan Room Subtotal Includes: gantry and table only, PDU is NOT in the Scan Room.	33,292	9,764
Control Room Subtotal Includes: console with 3 IG's, peripheral tower and LCD Monitors	6,000	1,757
System Total Heat Load (Includes: typical scan room and control room)	41,000	12,005
Options		
Remote Color Monitor (LCD)	425	125
UPS	2000	590
PDU Only (PDU heat load separate from the gantry and table)	1,708	500
Scan Suite Total Maximum Heat Load with options (See Note ¹)	43,425	12,720
NOTE 1: Maximum heat output reached at tube change. (Detailed Calibration)		
NOTE 2: Heat output does not include heat from room lighting, personnel or non-CT equipment.		

SYSTEM with NIOHD64 Console HEAT OUTPUT		
System Component	Maximum BTU/HR	Maximum WATT
Typical Scan Room Subtotal Includes: gantry, table, PDU, and peripherals	35,000	10,248
Non Typical Scan Room Subtotal Includes: gantry and table only, PDU is NOT in the Scan Room.	33,292	9,764
Control Room Subtotal Includes: LCD Monitors (Total amount of 2 monitors)	3200	940
System Total Heat Load (Includes: typical scan room and control room)	38,200	11,188
Options		
Remote Color Monitor (LCD)	425	125
UPS	2000	590
PDU Only (PDU heat load separate from the gantry and table)	1,708	500
Scan Suite Total Maximum Heat Load with options (See Note ¹)	40,625	11,903
NOTE 1: Maximum heat output reached at tube change. (Detailed Calibration)		

NOTE 2: Heat output does not include heat from room lighting, personnel or non-CT equipment.

Component Air Flow Requirements

The following illustrations show the recommended placements of the thermostat and HVAC vents (intake and output) for the scan and control rooms.

Figure 9-1 HVAC Air Vent Placement - SCAN ROOM

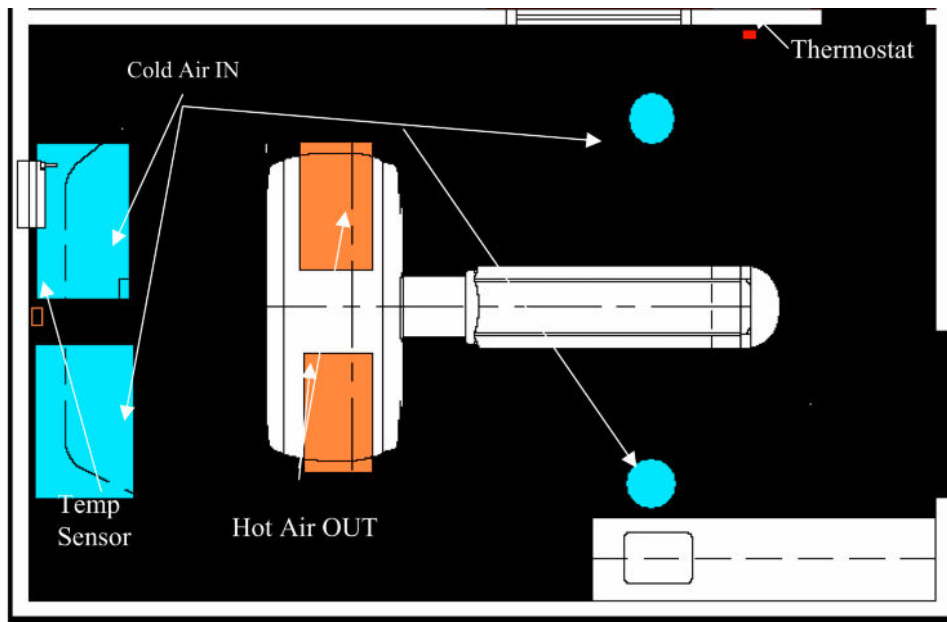
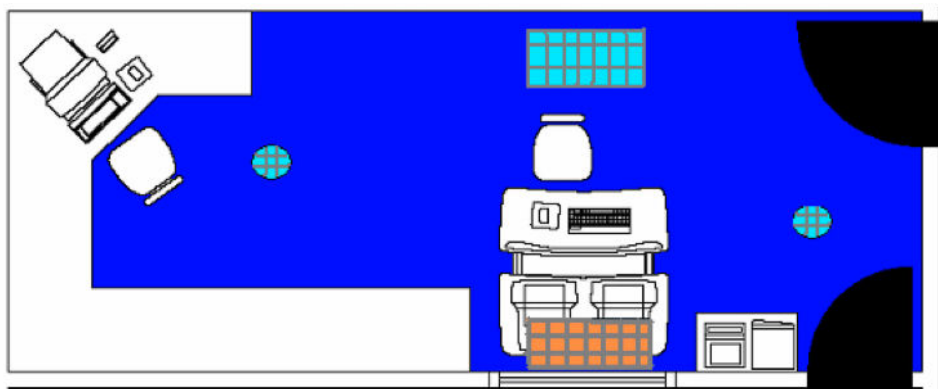

Figure 9-2 HVAC Air Vent Placement - CONTROL ROOM



Altitude

The system shall meet all functional and performance specifications when placed in a room that is at an elevation of -150 m to 2400 m (-492 ft to 7,875 ft) above sea level.

Air Quality

Dust and Air Quality Ensure that the scan suite is free of all dust, and not subject to ANY ongoing construction, including the installation of cabinets, hanging doors and ceiling tiles.

NOTICE

SERVICE NOTICE: Because the system's air-intake is near the bottom of the gantry and draws in air through a filter in the gantry heater assembly, fine dust—like that created during room construction or renovation—can clog this and other filters found on the DAS, tube, and console. If this occurs, dust may become deposited throughout the gantry, table, console, and PDU electronics. Once inside the unit, removal becomes impossible, resulting in potential **DAMAGE** to electronic components and **EARLY SYSTEM FAILURE**. Consequently, the system is the **LAST** item installed in the scan suite area.

TYPES OF DUST TO AVOID

Ensure that **NO** construction occurs in or immediately around the scan suite area that results in:

- concrete dust
- drywall dust
- ceiling tile dust
- wood sawdust or shavings
- dust tracked into the CT suite from adjoining rooms

Failure to take appropriate precautions to protect the system against these types of dust may result in **DAMAGE** to the system and early **SYSTEM FAILURE**.

Environmental Influences Considered CT systems are designed with commercial components that are sensitive to air contaminants like sulfide, chloride, and nitrates. It is the responsibility of the purchaser to ensure that the levels of these contaminants are low (Class 1). See IEC60654-4 for air quality guidelines.

Chemical Contamination Never install wet film processors in the same room as the system, as this may result in possible contamination of the system components. Chemicals utilized by such processors can contribute to increased equipment failures and downtime, and decreased reliability. When siting this equipment, consider the effects that contact with these chemicals and the resulting fumes might have on human subjects in proximity to them. In addition, film processor equipment installation must meet all manufacturer requirements (e.g. ventilation specifications) as well as all applicable local, state and national codes.

Electro-Magnetic Interference (EMI)

Gantry Locate the gantry in ambient static magnetic fields of less than 0.1 mTesla (1 Gauss) to guarantee the specified imaging performance. Ambient AC magnetic fields must measure below 1 μ Tesla (10 mGauss) peak.

Console Locate computer equipment in ambient static magnetic fields of less than 1 mTesla (10 Gauss) to guarantee data integrity (see [Figure 9-3 Equipment EMI “Envelopes” Sample Room Layout \(showing approximate EMI requirements\) on page 111](#)).

PDU The PDU produces an electromagnetic field that radiates outward from its cabinet in all directions. Do not place other sensitive electronics around or above the PDU.

UPS The Uninterruptable Power Supply (UPS) provides a consistent power supply to various electrical components of the system. Also, it continues to provide electrical power to components during a site-wide power outage so components can be safely shut down. The UPS should be kept at least one meter (1 m) (3.28 ft.) away from sensitive electronics (the PDU does not include sensitive electronics).

EMI Reduction If you know of or suspect the presence of fields of excessive EMI, consult GE Sales & Service for recommendations. Consider the following when attempting to reduce EMI:

- External field strength decreases rapidly with distance from source of the magnetic field.
- External leakage magnetic field of a three-phase transformer measure much less than that of a bank of three single-phase transformers of an equivalent power rating.
- Large electric motors constitute a source of substantial EMI.
- High-powered radio signals constitute a source of EMI.
- Maintain good screening of cables and cabinets.
- Consider and measure EMI fields of sites with main facility power running UNDER the floor or WITHIN the walls or ceilings of the scan room.
- Pay special attention to power substations and high-voltage power lines in proximity to the scan facility.
- If any concerns remain regarding excessive EMI fields, be sure to measure to confirm that your site meets all required specifications.

Figure 9-3 Equipment EMI “Envelopes” Sample Room Layout (showing approximate EMI requirements)

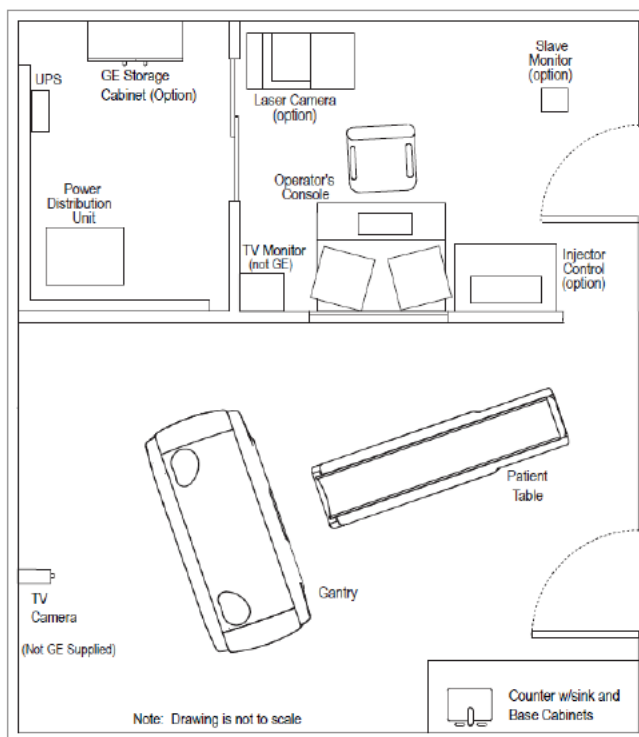

Electro-Magnetic Compatibility (EMC)

General Scope The Revolution Discovery CT / Revolution HD (system for short in the following) scanner complies with IEC60601-1-2 Edition 2.1 (2004) and IEC60601-1-2 Edition 3 (2007) EMC Standard.

The system scanner also complies with IEC60601-1-2 2014 Edition 4.0 and A1:2020 Edition 4.1 for the unit determined by means one of below:

- The scanner delivered with TRM, in the Regulatory chapter statement IEC60601-1-2 2014 Edition 4.0 or later compliance.
- The scanner installed with the below parts in Gantry:

Part	P/N EMC3.0	P/N EMC4.0	Description	Location
Slip Ring Receiver	5311644-3	5311644-4	10Gig SFP + Receiver	Gantry HLA
Slip Ring Transmitter	5311643-2	5311643-3	10Gig SFP + Transmitter	Gantry Slip Ring

The system is suitable to used in the Electromagnetic Environment, as per Environment of Intended Use and the limits & recommendations described in the tables hereafter:

- Emission Compliance level & limits (see [Table 9-1 Guidance and manufacturer's declaration – electromagnetic emissions on page 112](#))
- Immunity Compliance level & recommendations to maintain equipment clinical utility (see [Table 9-2 Guidance and manufacture's declaration - electromagnetic immunity on page 113](#), [Table 9-3 Guidance and manufacturer's declaration – electromagnetic immunity on page 114](#), [Table 9-4 Recommended separation distances between portable and mobile RF communications equipment and the Equipment on page 116](#) and [Table 9-5 Immunity and recommended separation between RF wireless communication equipment on page 117](#))



NOTE

This system complies with above mentioned EMC standard when used with the supplied cables. If different cable lengths are required, contact a qualified GE Service representative for advice.

Electromagnetic Emission

Table 9-1 Guidance and manufacturer's declaration – electromagnetic emissions

Guidance and manufacturer's declaration – electromagnetic emissions		
The system is intended for use in the electromagnetic environment specified below. The customer or the user of the system should assure that it is used in such an environment.		
Emissions Test	Compliance	Electromagnetic Environment Guidance
RF emissions CISPR 11 GB 4824	Group 1	The system uses RF energy only for its internal function. Therefore, its RF emissions are very low and are not likely to cause any interference in nearby electronic equipment.
RF emissions CISPR 11 GB 4824	Class A	The system is suitable for use in all establishments other than domestic and those directly connected to the public low-voltage power supply network that supplies buildings used for domestic purposes.
Harmonic emissions IEC 61000-3-2 GB 17625.1	Not applicable	

Table 9-1 Guidance and manufacturer's declaration – electromagnetic emissions (Table continued)

Guidance and manufacturer's declaration – electromagnetic emissions		
The system is intended for use in the electromagnetic environment specified below. The customer or the user of the system should assure that it is used in such an environment.		
Emissions Test	Compliance	Electromagnetic Environment Guidance
Voltage fluctuations / flicker emissions IEC 61000-3-3 GB 17625.2	Not applicable	

**NOTE**

GB4824, GB17625.X and GB17626.X standard apply to China only.

**NOTE**

The EMISSIONS characteristics of this equipment make it suitable for use in industrial areas and hospitals (CISPR 11 / GB 4824 class A). If it is used in a residential environment (for which CISPR 11 / GB 4824 class B is normally required), this equipment might not offer adequate protection to radio-frequency communication services. The user might need to take mitigation measures, such as relocating or re-orienting the equipment.

Electromagnetic Immunity**Table 9-2 Guidance and manufacture's declaration - electromagnetic immunity**

Guidance and manufacture's declaration - electromagnetic immunity			
The system is intended for use in the electromagnetic environment specified below. The customer or the user of the system should assure that it is used in such an environment.			
Immunity Test	EC 60601 Test Level	Compliance Level	Electromagnetic Environment - Guidance
Electrostatic discharge (ESD) IEC 61000-4-2 GB/T 17626.2	±6 kV contact ±8 kV air ±8 kV contact ^{a)} ±15 kV air ^{a)}	±6 kV contact ±8 kV air ±8 kV contact ^{a)} ±15 kV air ^{a)}	Floors should be wood, concrete, or ceramic tile. If floors are covered with synthetic material, the relative humidity should be at least 30%.
Electrical fast transient/burst IEC 61000-4-4 GB/T 17626.4	±2 kV for power supply lines ±1 kV for input/output lines	±2 kV for power supply lines ±1 kV for input/output lines	Mains power quality should be that of a typical commercial or hospital environment.
Surge IEC 61000-4-5 GB/T 17626.5	±1 kV line-line ±2 kV line-earth	±1 kV line-line ±2 kV line-earth	Mains power quality should be that of a typical commercial or hospital environment.
Voltage dips, short interruptions and voltage variations on power supply input lines IEC 61000-4-11 GB/T 17626.11	<5 % U_T for 0.5 cycle (>95 % dip in U_T) 40 % U_T for 5 cycles (60 % dip in U_T) 70 % U_T for 25 cycles (30 % dip in U_T)	Not applicable	Mains power quality should be that of a typical commercial or hospital environment. If the user of the system requires continued operation during power mains interruptions, it is recommended that the system be powered from

Table 9-2 Guidance and manufacture's declaration - electromagnetic immunity (Table continued)



Guidance and manufacture's declaration - electromagnetic immunity			
The system is intended for use in the electromagnetic environment specified below. The customer or the user of the system should assure that it is used in such an environment.			
Immunity Test	EC 60601 Test Level	Compliance Level	Electromagnetic Environment - Guidance
	<5 % U_T for 5s (>95 % dip in U_T) $0\%U_T, 5s^a$	<5 % U_T for 5s (>95 % dip in U_T) $0\%U_T, 5s^a$	an uninterruptible power supply or a battery.
Power frequency (50/60Hz) magnetic fields IEC 61000-4-8 GB/T 17626.8	3 A/m 30 A/m ^{a)}	3 A/m 30 A/m ^{a)}	Power frequency magnetic fields should be at levels characteristic of a typical location in a typical commercial or hospital environment.
Proximity Magnetic Fields ^{a)} IEC 61000-4-39	8 A/m 30 kHz	Not applicable	
	65 A/m 134.2 kHz 7.5 A/m 13.56 MHz	65 A/m 134.2 kHz 7.5 A/m 13.56 MHz	
<p> NOTE U_T is the a.c. mains voltage prior to application of the test level.</p> <p> NOTE ^{a)} For IEC 60601-1-2:2014 Ed4.0 and A1:2020 Ed4.1, Proximity Magnetic Fields apply to IEC 60601-1-2 Ed4.1 only.</p>			

Table 9-3 Guidance and manufacturer's declaration – electromagnetic immunity

Guidance and manufacturer's declaration - electromagnetic immunity			
The system is intended for use in the electromagnetic environment specified below. The customer or the user of the system should assure that it is used in such an environment.			
Immunity Test	IEC 60601 Test Level	Compliance Level	Electromagnetic Environment - Guidance
Conducted RF IEC 61000-4-6 GB/T 17626.6	3Vrms 150 kHz ~ 80 MHz 6Vrms ^{a)} ISM bands between 150 kHz and 80 MHz 80%AM at 1kHz	3Vrms 6Vrms ^{a)} ISM bands between 150 kHz and 80 MHz	Portable and mobile RF communications equipment should be used no closer to any part of the system, including cables, than the recommended separation distance calculated from the equation appropriate to the frequency of the transmitter Recommended Separation Distance $d = 1.2\sqrt{p}$

Table 9-3 Guidance and manufacturer's declaration – electromagnetic immunity (Table continued)





Guidance and manufacturer's declaration - electromagnetic immunity			
The system is intended for use in the electromagnetic environment specified below. The customer or the user of the system should assure that it is used in such an environment.			
Immunity Test	IEC 60601 Test Level	Compliance Level	Electromagnetic Environment - Guidance
Radiated RF Fields IEC 61000-4-3 GB/T 17626.3	3V/m 80 MHz ~ 2.5/2.7 ^{a)} GHz 80% AM at 1kHz	3V/m	$d = 1.2\sqrt{P}$ 80 MHz ~ 800 MHz $d = 2.3\sqrt{P}$ 800 MHz ~ 2.5/2.7 ^{a)} GHz where <i>P</i> is the maximum output power rating of the transmitter in watts (W) according to the transmitter manufacturer and <i>d</i> is the recommended separation distance in meters (m).
Proximity fields from RF Wireless communications equipment a) IEC 61000-4-3	refer to Table 9-5 Immunity and recommended separation between RF wireless communication equipment on page 117	refer to Table 9-5 Immunity and recommended separation between RF wireless communication equipment on page 117	Field strengths from fixed RF transmitters, as determined by an electromagnetic site survey, ^a should be less than the compliance level in each frequency range. ^b Interference may occur in the vicinity of equipment marked with the following symbol: 
<p> NOTE At 80 MHz and 800 MHz, the higher frequency range (6.765 MHz~6.795 MHz , 13.553 MHz~ 13.567 MHz, 26.957 MHz~27.283 MHz, 40.66 MHz~40.70 MHz) applies.</p> <p> NOTE These guidelines may not apply in all situations. Electromagnetic propagation is affected by absorption and reflection from structures, objects, and people.</p> <p> NOTE a) For IEC 60601-1-2:2014 Ed4.0 and A1:2020 Ed4.1.</p>			
<p>^a Field strengths from fixed transmitters, such as base stations for radio (cellular/cordless) telephones and land mobile radios, amateur radio, AM and FM radio broadcast, and TV broadcast cannot be predicted theoretically with accuracy. To assess the electromagnetic environment due to fixed RF transmitters, an electromagnetic site survey should be considered. If the measured field strength in the location in which the system is used exceeds the applicable RF compliance level above, the system should be observed to verify normal operation. If abnormal performance is observed, additional measures may be necessary, such as re-orienting or relocating the system.</p> <p>^b Over the frequency range 150 kHz to 80 MHz, field strengths should be less than 3V/m.</p>			

Table 9-4 Recommended separation distances between portable and mobile RF communications equipment and the Equipment

Recommended separation distances between portable and mobile RF communications equipment and the system			
The system is intended for use in an electromagnetic environment in which radiated RF disturbances are controlled. The customer or the user of the system can help prevent electromagnetic Interference by maintaining a minimum distance between portable and mobile RF communications equipment (transmitters) and the system as recommended below, according to the maximum output power of the communications equipment			
Rated maximum output power (P) of transmitter (W)	Separation distance according to frequency of transmitter		
	150 kHz ~ 80 MHz $d = 1.2\sqrt{p}$	80 MHz ~ 800 MHz $d = 1.2\sqrt{p}$	800 MHz ~ 2.5/2.7 ^{a)} GHz $d = 2.3\sqrt{p}$
0.01	0.12	0.12	0.23
0.1	0.38	0.38	0.74
1	1.2	1.2	2.3
10	3.8	3.8	7.3
100	12	12	23

For transmitters rated at a maximum output power not listed above, the separation distance can be estimated using the equation in the corresponding column, where P is the maximum output power rating of the transmitter in watts (W) according to the transmitter manufacturer.

NOTE
At 80 MHz and 800 MHz, the separation distance for the higher frequency range applies.

 **NOTE**
These guidelines may not apply in all situations. Electromagnetic propagation is affected by absorption and reflection from structures, objects, and people.

 **NOTE**
a) For IEC 60601-1-2:2014 Ed4.0 and A1:2020 Ed4.1.

 **WARNING**



PORTABLE RF COMMUNICATIONS EQUIPMENT (INCLUDING PERIPHERALS SUCH AS ANTENNA CABLES AND EXTERNAL ANTENNAS) SHOULD BE USED NO CLOSER THAN 30 CM (12 INCHES) TO ANY PART OF THE SYSTEM, INCLUDING CABLES SPECIFIED BY THE MANUFACTURER. OTHERWISE, DEGRADATION OF THE PERFORMANCE OF THIS EQUIPMENT COULD RESULT.

Table 9-5 Immunity and recommended separation between RF wireless communication equipment

Immunity and recommended separation between RF wireless communication equipment for IEC60601-1-2 Edition 4				
Portable RF communications equipment (including peripherals such as antenna cables and external antennas) at frequencies noted below should be used no closer than 30cm (12 inches) to any part of the system, including cables specified by the manufacturer. Otherwise, degradation of the performance of this equipment could result.				
Minimum separation distances for higher IMMUNITY TEST LEVELS shall be calculated using the following equation:				
$d = \left[\frac{6}{E} \right] \sqrt{P}$				
Where P is the maximum power in W, d is the minimum separation distance in m, and E is the IMMUNITY TEST LEVEL in V/m.				
Test frequency (MHz)	Band (MHz)	Service	Maximum Power (W)	IMMUNITY TEST LEVEL (V/m)
385	380-390	TETRA 400	1.8	27
450	430-470	GMRS 460 FRS 460	2	28
710	704-787	LTE Band 13, 17	0.2	9
745				
780				
810	800-960	GSM 800/900 TETRA 800 IDEN 820 CDMA 850 LTE Band 5	2	28
870				
930				
1720	1700-1990	GSM 1800 CDMA 1900 GSM 1900 DECT LTE Band 1, 3, 4, 25 UMTS	2	28
1845				
1970				
2450	2400-2570	Bluetooth WLAN 802.11 b/g/n RFID 2450 LTE Band 7	2	28
5240	5100-5800	WLAN 802.11 a/n	0.2	9
5500				
5785				

Use Limitation:

The scanner is intended for use only by trained professionals who must be trained in CT system operation and has sufficient knowledge of radiation, scan setting, image annotation and review, the operator shall understand the operation and expected performance of the system per training and reading of the operator manual and technical reference manual.

The scanner is expected to be able to position patient, scan, display or output images with annotation and without artifact or noise that emulate or hide pathology, timely and accordingly. Test per chapter Quality Assurance to ensure scanner performance as expectation, Daily preparation procedure and calibration shall be used to maintain scanner performance and prevent failure or degradation before use. Contact GE service if any failure.

The table below described some possible failure or degradation of performance need to check before further use.

Function	Performance Failure and Detection	Instruction to Check or Maintain
Patient positioning	Unintended motion or positioning	Manual check table positioning or positioning patient successfully during scan
Scan	Unintended scan exposure	Check scan control button response as expected Daily prepare or Test per Quality Assurance
Image annotation	Unintended image annotation or scan setting	Complete patient information and scan settings accordingly before scan, ensure keyboard and display response as expected
Display and output	Unexpected display or output, not available for visual check or diagnose	Daily prepare or test per Quality Assurance, ensure scan recon setting, display and printer function as expected
IQ/artifact	Unexpected artifact or noise that emulate or hide pathology	Daily prepare or test per Quality Assurance, ensure Image Quality according with spec. Verify CT# for air, water and object scanned for doubts in the image
Image delay	Unexpected scan image time delay	Daily prepare or test per Quality Assurance, verify scan and recon setting.

The system should be installed, maintained and used per guidance in EMC section for safety and expected performance. To use per guidance, separate from other device sensitive or with EM disturbance will help to maintain the performance of the scanner and other device.

 **WARNING**



THIS SYSTEM IS INTENDED FOR USE BY HEALTHCARE PROFESSIONALS ONLY. THIS SYSTEM MAY CAUSE RADIO INTERFERENCE OR MAY DISRUPT THE OPERATION OF NEARBY EQUIPMENT. IT MAY BE NECESSARY TO TAKE MITIGATION MEASURES, SUCH AS REORIENTING OR RELOCATING THE SYSTEM OR SHIELDING THE LOCATION.

 **WARNING**



CT SCANS MAY CAUSE INTERFERENCE WITH IMPLANTED OR EXTERNALLY WORN ELECTRONIC MEDICAL DEVICES SUCH AS PACEMAKERS, DEFIBRILLATORS, NEURO STIMULATORS AND DRUG INFUSION PUMPS. THE INTERFERENCE COULD CAUSE OPERATIONAL CHANGES OR MALFUNCTION OF THE ELECTRONIC MEDICAL DEVICE.

Use of RF (Radio Frequency) sources that intentionally transmit, such as cellular telephones, transceivers, radio-controlled products, or other RF emitting equipment may cause performance outside the systems published specifications or other adverse operation. Keep the power to these RF sources turned off when near this equipment. Recommended separation distances and information regarding compatibility with other equipment are located in the Manufacturer’s EMC Declaration Tables.

Operation of the accessories like EKG monitor and respiratory gating device below the manufacturer specified minimum amplitude or value of patient physiological signals may cause inaccurate results.

Only transducers and cables GE specified can be replacement parts for internal components, details of components and cables refer to Pre-Installation Manual.

The use of accessories, transducers, and cables other than those specified in GE Approved Accessories may result in increased emissions or decreased immunity performance of the equipment.

⚠ WARNING



USE OF ACCESSORIES, TRANSDUCERS AND CABLES OTHER THAN THOSE SPECIFIED OR PROVIDED BY THE MANUFACTURER OF THIS EQUIPMENT COULD RESULT IN INCREASED ELECTROMAGNETIC EMISSIONS OR DECREASED ELECTROMAGNETIC IMMUNITY OF THIS EQUIPMENT AND RESULT IN IMPROPER OPERATION.

Installation Requirements & Environment Control:

In order to minimize interference risks, the following requirements shall apply.

Environment of Intended Use

This medical device is evaluated to the IEC60601-1-2 safety standard electromagnetic emissions and immunity levels in the Professional Healthcare Facility environment category, predominantly for use in hospital except for near active HF SURGICAL EQUIPMENT or SHORT-WAVE THERAPY EQUIPMENT with a dedicated supply system, and with an X-ray shielded room. The equipment is not directly connected to the Public Mains Network.

The CT System is exposed to EM sources generally from LAN and WLAN, mobile phones, paging systems, computers, printers, monitors, and other medical devices. See sections in this manual for the electromagnetic disturbance compliance levels this product meets including a list of wireless communications services evaluated.

This medical device is not suitable for use in certain hospital environments. Electrical devices that are brought into the CT System room that generate intense EM disturbances have not been considered per the safety standard. Also, the CT System compliance levels don’t guarantee that other equipment in the room that is EM sensitive is not impacted. The IEC60601-1-2 safety standard requires additional testing and/or risk assessment for compliance and patient/operator safety of the CT system.

Table 9-6 Environment of Intended Use Statement

Environment of Intended Use	
This medical device is evaluated to the IEC60601-1-2 safety standard electromagnetic emissions and immunity levels in the environment category shown below.	
Environment Category	Examples

Table 9-6 Environment of Intended Use Statement (Table continued)

Professional Healthcare Facility	EM sources generally are from LAN and WLAN, mobile phones, paging systems, IT equipment, medical devices: Physician Offices / Clinics / Limited Care Facilities / Freestanding Surgical Centers / Multiple Treatment Facilities / Hospitals / Trailer connected to Hospital power (apply if have mobile configuration)
Environment Exclusions	
This medical device may not be suitable for use in the IEC60601-1-2 safety standard environment categories listed below. The types of electromagnetic disturbances emitted from electrical devices found in these environments and their effect on the performance of this medical device have not been considered per the safety standard. The safety standard requires additional testing and/or risk assessment for compliance and patient/operator safety of the CT system.	
Environment Category	Examples
Home Healthcare Environment	Locations that have diverse electromagnetic disturbances. Category includes transportation: Residences / Homes / Nursing Homes / Vehicles (Cars, Trains, Planes) / Mobile Emergency Medical Services / Airports / Outdoors
Special Environment - Medical	EM sensitive locations or sources of intense emissions: Rooms with HF surgical equipment / Rooms with short-wave therapy equipment / Inside RF shielded room of an MRI system.
Special Environment - Military	Unique locations that have not been EM characterized: Near Radar Installations / Near Weapons Control Systems
Special Environment - Industrial	Unique locations that have not been EM characterized: Power Plants / Manufacturing Facilities / Mining / Refineries / Mills

Cable Shielding & Grounding All interconnect cables to peripheral devices must be shielded and properly grounded. Use of cables not properly shielded and grounded may result in the equipment causing radio frequency interference.

Subsystem & Accessories Power Supply Distribution

All components, accessories subsystems, systems which are electrically connected to the system, must have all AC power supplied by the same power distribution panel & line.

Stacked Components & Equipment

System should not be used adjacent to or stacked with other equipment; if adjacent or stacked use is necessary, System should be observed in order to verify normal operation in the configuration in which it will be used.



USE OF THIS EQUIPMENT ADJACENT TO OR STACKED WITH OTHER EQUIPMENT SHOULD BE AVOIDED BECAUSE IT COULD RESULT IN IMPROPER OPERATION. IF SUCH USE IS NECESSARY, THIS EQUIPMENT AND THE OTHER EQUIPMENT SHOULD BE OBSERVED TO VERIFY THAT THEY ARE OPERATING NORMALLY.

Low Frequency Magnetic Field

In case of a digital System, the Gantry (digital detector) shall be apart 1 meter from the generator cabinet, and 1 meter apart from the analog (CRT) monitors. These distance specifications will minimize the low frequency magnetic field interference risk.

Static Magnetic Field Limits

In order to avoid interference on system, static field limits from the surrounding environment are specified.

Static field is specified less than <1 Gauss in Examination room, and in the Control Area.

Static field is specified less than <3 Gauss in the Technical Room.

Electrostatic Discharge Environment & Recommendations

In order to reduce electrostatic discharge interference, install a charge dissipative floor material to avoid electrostatic charge buildup.

The relative humidity shall be at least 30 percent.

The dissipative material shall be connected to the system ground reference, if applicable.

System Component Noise Levels

Maximum Gantry Audible Noise Level The maximum ambient noise level is produced by the gantry during a CT scan acquisition. It is less than 75 dBA when measured at a distance of one meter from the nearest gantry surface, in any direction.

Page intentionally left blank

Chapter 10 Radiation Protection Requirements

10.1 Radiation Protection Requirements

NOTICE

Engage a QUALIFIED RADIOLOGICAL HEALTH PHYSICIST to review your scan room shielding requirements.

Take into consideration the following during a scan room review:

- Scatter radiation levels within the scanning room (See Illustrations in this chapter).
- Equipment placement.
- Weekly projected workloads (number of patients/day technique [kvp*ma]).
- Materials used for construction of walls, floors, ceiling, doors, and windows.
- Activities in surrounding scan room areas.
- Equipment in surrounding scan room areas (e.g. film developer, film storage)
- Room size and equipment placement within the room relative to room size.

Shielding Requirements The illustrations in this chapter depict measured radiation levels within the scanning room, while scanning a 32 cm CTDI phantom placed on the patient table and using a large filter, with the technique shown. Use the mAs, kV and aperture scaling factors in the table shown here to adjust exposure levels to the scan technique used at the site.

Example: (using the Illustration) The exposure level for a 120 kV, 800 mA, 1 sec. scan at 1270 mm (50 in) away from the scan place is $10.4 \mu\text{Gy} \times 0.71 \times 800/100 = 59.2 \mu\text{Gy}$



NOTE

Actual measurements can vary. Expected deviation equals $\pm 15\%$, except for the 5 mA and 1 mm techniques, where variation may be greater (up to a factor of 2), due to the inherent deviation in small values. The maximum deviation anticipated for tube output equals $\pm 40\%$.

Table 10-1 Shielding Requirements Scaling

Changed Parameter	Multiplication Factor
mAs	new mAs/100
80 kV	0.24
100 kV	0.45
120 kV	0.71
140 kV	1.00
1 mm aperture	0.20
3 mm aperture	0.22

Table 10-1 Shielding Requirements Scaling (Table continued)

Changed Parameter	Multiplication Factor
5 mm aperture	0.27
10 mm aperture	0.38
15 mm aperture	0.48
20 mm aperture	0.59
30 mm aperture	0.79
40 mm aperture	1.00

NOTICE

This publication uses μGy (micrograys) to measure radiation levels. The conversion factor from mR to μGy (micrograys) is: $1 \text{ mR} = 8.76 \mu\text{Gy}$.

**NOTE**

Data in the figures included in this chapter may change prior to product release.

Figure 10-1 Typical Scatter Survey (Large Filter)

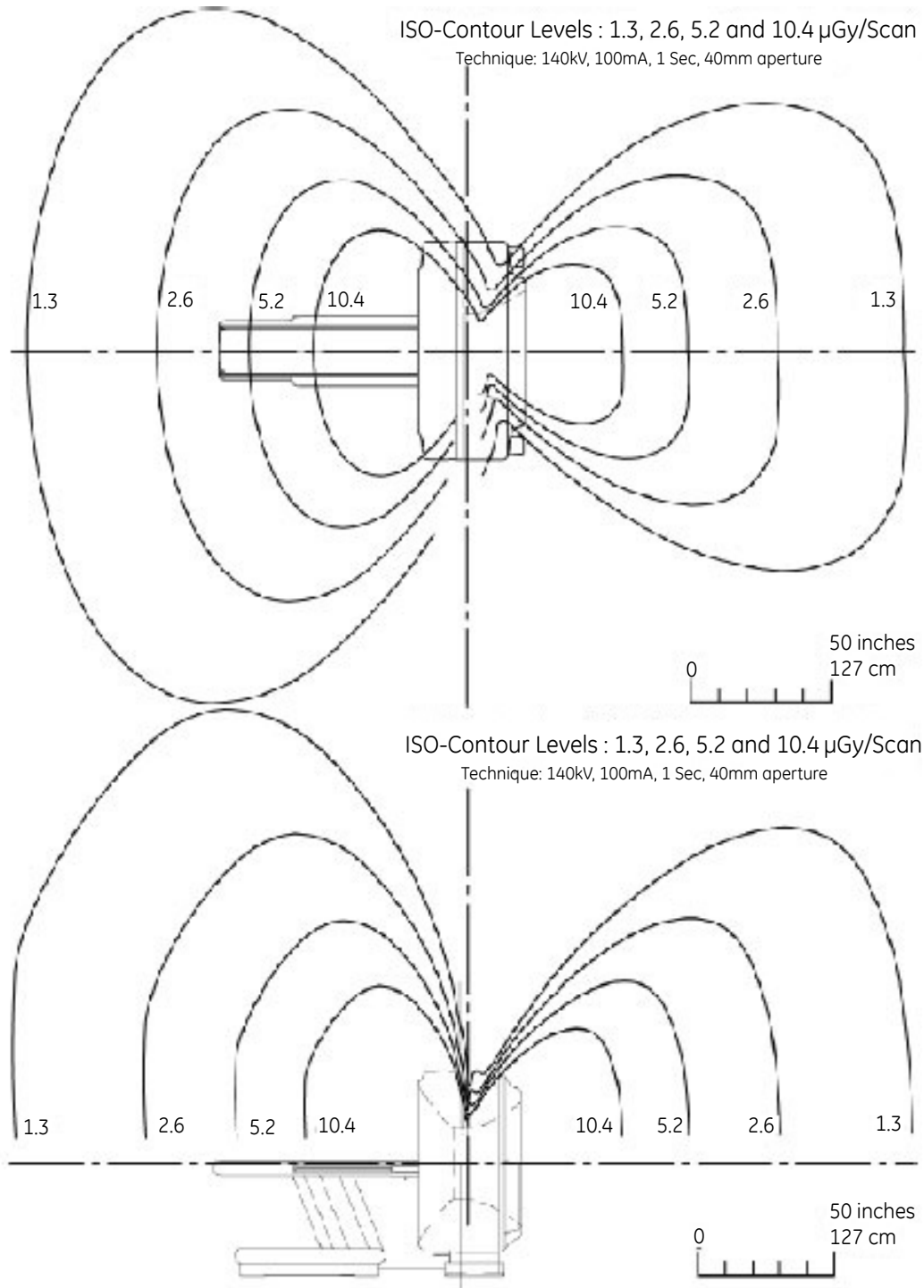

NOTE

The 20cm water phantom should be placed on the phantom holder inserted into the end of the patient table.

Figure 10-2 Typical Scatter Survey (Small and Medium Filter)

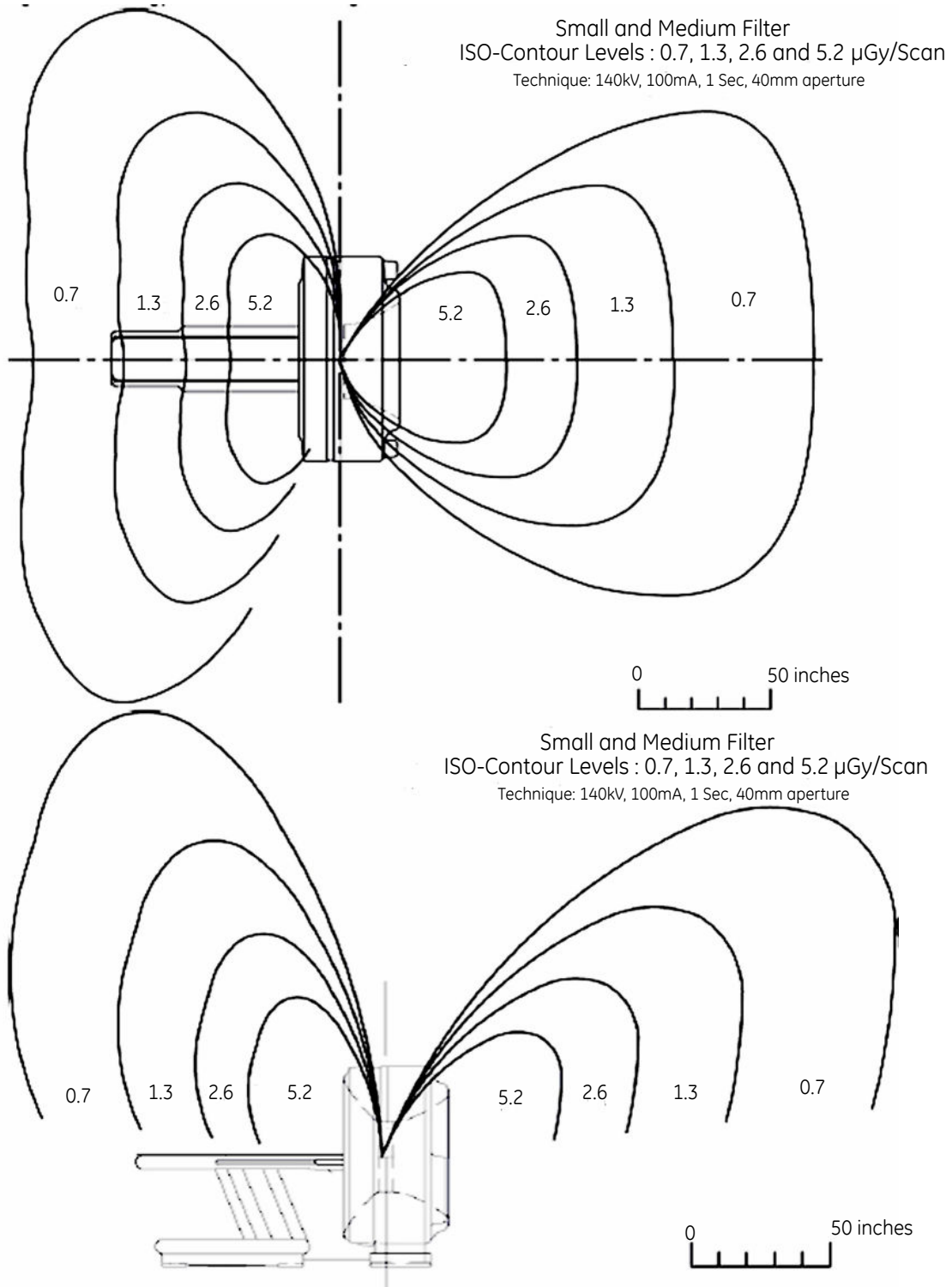

Chapter 11 Network Requirements

11.1 Network Requirements

NETWORK CONNECTIONS

The network requirements listed in this chapter should allow you to connect the system to:

- Hospital/facility networks
- Filming cameras
- PACS
- Workstations
- Patient Information Systems

Network Type The CT system requires a broadband network connection.

Network Speed The customer and the customer's IT contact should ensure that the site provides access to broadband using one of the following interface types: 100BASE-TX (100 Mbit/s) or 1000BASE-T (1000 Mbit/s [1 Gbit/s]).

Network Cable Routing The CT system connects to the facility's network through the console. To enable proper network cabling, the customer and the customer's IT contact should:

- Provide an RJ45 wall outlet within 2 m (79 in) of the console location.
- Provide a patch cable, not to exceed 3.05 m (10 ft), to connect the operator console to a wall box.
- Complete any cable duct work or conduit installation that the customer site unit might require to route connecting network cables to the workstation, camera, and operator console.
- Ensure that the run from the hospital/facility switch to the CT wall outlet does not exceed 88 m (290 ft). Bandwidth performance degrades significantly when the length exceeds 91 m (300 ft.)

CUSTOMER BROADBAND RESPONSIBILITIES

Contact GE to find ZONE Broadband Specialist Contact your GE PM to obtain the name of the zone broadband specialist who will:

1. Work with the Customer Champion to complete any identified infrastructure changes.
2. Provide IP addresses for new CT equipment.
3. Provide a VPN compatible appliance that will support the IPSec tunneling protocol and 3DES data encryption.
4. Utilize an Internet Service Provider that supports static routing.

Provide GE with IT Contact Information for the Site Provide your GE PM with an accurate site address, telephone number, contact name and email address for the customer IT contact who will:

1. Coordinate VPN activities between Radiology/Cardiology and the Information Technology (IT) departments.
2. Act as a focal point in assuring site broadband infrastructure meets GE Healthcare requirements for connection, as determined by a mutual assessment with the GE Healthcare connectivity team.

3. Complete an equipment assessment with the GE Healthcare connectivity team to determine site readiness for broadband.

DIGITAL SERVICE AND CONNECTIVITY REQUIREMENTS

Background

GE Healthcare provides digital service and asset management through its InSite Connectivity Platform. InSite RSvP (Remote Service Platform) is the latest connectivity platform that will eventually replace the existing InSite 1 connectivity infrastructure in the system.

GE can proactively monitor the key operational parameters of your medical systems to provide early warning of potential issues to head off costly and unscheduled downtime. The GE online engineers can recalibrate key operational parameters to help ensure optimal system performance or can dispatch a field engineer to assist in mitigating the issue. Additionally, automated software downloads require reliable connectivity platform to ensure software updates and upgrades in a timely manner to keep the system working efficiently. Software downloads also significantly reduce the time it takes to upgrade your GE Healthcare devices, which means the scheduled system downtime and clinical workflow interruptions are greatly reduced.

The two major technical components of InSite RSvP are Agent and Server. The Agent is installed on the GE Healthcare equipment at the customer sites while the Server resides within GE Healthcare. The role of the Agent is to:

- monitor device performance data on an ongoing basis,
- establish secure communications to the Server via the Internet,
- and send fault information and log files to the Server

The Server uses the secure Web Services to communicate with the Agent. It processes the performance and fault information provided by the Agent.

InSite RSVP Connectivity Requirements

The Agent establishes connectivity from behind the safety of your corporate firewall, adhering to all the security policies set up by your network administrators. To your network, the Agent is just another computer on the LAN. To set up the InSite 2.0 Agent at your site, the only networking requirements are as follows:

1. A physical connection or a route to an existing enterprise LAN
2. Allow outbound Internet access for the device using HTTPS protocol over port 443

If the CT system is already at or upgrades to software version 21BW26.xx or later, a GE Healthcare Field Engineer will configure network connections for InSite RSVP connectivity according to the site IT requirements.

Customer IT personal would need to ensure the following details to enable connectivity at install:

1. DNS IP Address or Proxy IP address and authentication information as applicable is made available when requested by the GE Field Engineer or Project manager of Installation
2. In case it is required to whitelist, only certain URLs being used by GE Healthcare, here is a list that could be used:
 - a. Enterprise production: <https://insite.gehealthcare.com:443>
 - b. Flexera URL: <https://gehealthcare-ns.flexnetoperations.com>

InSite RSVP utilizes existing the outbound broadband internet connection. It uses the Secure Sockets Layer (SSL) and complies with the existing firewall rules and Web proxies. Once the Agent has

established a secure tunnel, the connection is visible only to InSite RSVP clients and services (applications or user

**NOTE**

For GEHC Personnel only:

1. If a customer is not able to provide the internet connection then GEHC needs to provide the internet connection along with the required router device.
2. If a customer has GEHC provided internet connection or has GEHC provided router device running on the customer provided internet connection then consult the customer if the same set is to be used.

Page intentionally left blank

Chapter 12 Power Requirements

12.1 Power Requirements

Be sure to communicate all necessary information in this chapter to the electrical contractor employed at the installation site.

The Power Distribution Unit (PDU) supplied with the CT system transforms and distributes power to all system components. The PDU constitutes the only power entry point required to operate the system. To minimize voltage regulation effects, keep power wiring between the facility main distribution panel and the PDU as short as possible.

When routing the power wiring, all three-phase wires and ground must run in the same conduit or raceway duct. Route power wires separate from the system control and signal cables, using a separate conduit or trough in a raceway duct. You may use a metallic conduit, floor duct, or surface raceway for running cables, depending upon local codes and practices. However, ensure that cable passageways are large enough to install additional cables with all other cables already installed. Do not use non-metallic conduit.

System Input Power

Power Source Configuration The CT system scanner operates on a three-phase, solidly grounded four-wire WYE or Delta power source. The neutral wire does not need to run to the system, (i.e. four-wire connection). If you are running a NEUTRAL wire, terminate it in the A1 box.

A dedicated feeder from the nearest Main Distribution Panel (MDP) should supply power to the scanner. In accordance with the National Electric Code (U.S.) and similar applicable national and local codes, the site MUST provide a protective disconnect device with LOCK-OUT and TAG-OUT provisions in the power line supplying the PDU, and MUST locate the protective disconnect device within 10 m (32 ft) of the PDU, visible to PDU service personnel. The disconnect device appears as **A1** in the interconnection schematic diagrams.



NOTE

The recommended wiring configuration for the scanner is “WYE”. Delta configuration is not recommended due to potential damage caused to the PDU upon the failure of any one of the incoming phases.

Rating The CT system operates on three-phase power that meets the following specifications:

- Voltage - 380 to 480 VAC
- Capacity - 150 kVA
- Frequency - 50 or 60 Hz \pm 3 Hz
- Maximum (momentary peak power) demand = 150 kVA @ 0.85 PF at a selected technique of 140 kV, 765 mA.
- Average power demand at maximum duty cycle = 11 kVA (or Less).

Refer to *System Power Wire Sizing* in this chapter.

The A1 disconnect device reference above must provide over-current protection for the system and have at least one *Emergency OFF* switch within the scan suite, near the console. The preferred

disconnect utilizes under-voltage release control, rather than shunt trip devices. The rating of the A1 disconnect device depends on the nominal line voltage at the site. Refer to this chapter for minimum rating requirements and suggested disconnect devices.



WARNING

TO PREVENT POWER LOSS TO OTHER LOADS,
in case of an unexpected ct or pet system fault,

the power feeder must have over-current protection such that the downstream over-current protection devices (GE a1 panel) clear the fault before any up-stream over-current protection device opens.

Regulation Total load regulation, as measured at the PDU input terminals, must not exceed 6%. The capacity of the facility transformer and size and length of feeder wires directly affect the load regulation presented to the system. For recommended single-unit installation specifications see next section on *Recommended Power Distribution System*.

Phase Imbalance The difference between the highest line-to-line voltage and lowest line-to-line voltage must not exceed 2% of the lowest line-to-line voltage.

Sags, Surges, and Transients Sags and surges of the power line must not exceed the absolute range limits shown in the Table in this chapter. Limit maximum transient voltages to 1500 V peak.

Grounding The customer's electrician needs to perform the following tasks:

- Bond metal conduit, raceway, or the armor of armored cable used to power the system to the PDU cabinet and to the PDU cabinet and the A1/MDP Disconnect.
- Run a dedicated 1/0 (50 mm²) or larger insulated copper ground wire from the main distribution panel to the PDU with the phase wires.
- Run the ground wire with the three-phase wires from the power source to the A1/MDP Disconnect and from A1/MDP Disconnect to the PDU. Grounding does not require a neutral wire.

NOTE

The shield or armor of armored cable ALONE does NOT provide sufficient grounding.

Bond the ground wire to the intermediate distribution panels through which it passes in accordance with local codes. The resistance between the PDU ground and the facility earth ground must not exceed 0.5 ohm. In addition, the total resistance between the PDU ground and earth must not exceed 2 ohms. In addition:

- The facility ground for the CT system must originate at the system power source (i.e., transformer or first access point of power into the facility) and be continuous to the CT system A1/MDP Disconnect in the room
- Main facility ground conductor to A1/MDP Disconnect must be appropriately sized insulated copper wire.
- Run a dedicated 1/0 (50 mm²) or larger insulated copper ground wire from A1/MDP to PDU. The main facility ground to the A1/MDP disconnect must meet local codes, in all cases the recommended ground wire is a 1/0 (50 mm²) ground wire.

Bond the ground wire to the intermediate distribution panels through which it passes in accordance with local codes. The resistance between the PDU ground and the facility earth ground must not

exceed 0.5 ohm. In addition, the total resistance between the PDU ground and earth must not exceed 2 ohms.

Recommended Power Distribution System

In all cases, qualified personnel must verify that the transformer and feeder (at the point of take off) and the run to the CT scanner meet all the requirements stated in this document.

WARNING



IF THE POWER FEED FOR THE A1/PDB PANEL IS NOT ON A DEDICATED POWER TRANSFORMER,

any device that shares power from that transformer may be impacted by inadvertent power interruption caused by an a1/pdb power panel fault.

Conversly, the operation of other devices sharing the power transformer may also impact the operation of the ct/pet scanner.

Using a Dedicated Distribution Transformer (Recommended) The recommended power distribution system for a CT scanner is a dedicated feeder from the facility main isolation transformer. The minimum recommended transformer size for a dedicated distribution transformer provided for the scanner is 225 kVA, rated 2.4% regulation at unity power factor. The table in this section show the minimum recommended feeder size and over-current protection device based on line voltage for this configuration.

Using an Existing Distribution Transformer If it proves necessary to power the scanner from an existing distribution transformer and secondary feeder, such as the equipment distribution panel of an X-ray department, avoid installation with other X-ray equipment that uses rapid film changers. These changers use a large number of high-powered, closely-spaced exposures, which may coincide with the CT scan and produce image artifacts.

System Power Requirements Be sure that the site can meet all of the minimum power requirements listed below before installing the system:

- Maximum (momentary peak power) demand = 150 kVA @ 0.85 PF: at a Selected technique of 140 kV, 765 mA.
- Average effective (RMS) power demand at maximum duty cycle = 30 kVA
- Average power demand at maximum duty cycle = 11 kVA (or less).
- Maximum allowable total source regulation is 6%.
- Minimum recommended transformer size: 225 kVA, with 2.4% rated regulation at unity power factor. Resultant maximum allowable feeder regulation is 3.4%.

Table 12-1 Nominal Line Voltage Ranges

Nominal line voltage MUST fall within ONE of these ranges.						
Nominal Line Voltage	380	400	420	440	460	480
Hi-Line Limit, +10%	418	440	462	484	506	528
Lo-Line Limit, -10%	342	360	378	396	414	432
Continuous Line Current	38	36	34	33	31	30
Momentary Line Current	228	217	206	197	188	180
Maximum Line Current	253	241	229	219	209	200

Table 12-1 Nominal Line Voltage Ranges (Table continued)

Nominal line voltage MUST fall within ONE of these ranges.						
Minimum Recommended Circuit Protection Rating	150	150	150	125	125	125

Table 12-2 Minimum Feeder Wire Size

Feeder Length	Minimum Feeder Wire Size, AWG or MCM (sq. mm)/ VAC					
(Power Substation to A1 Disconnect)	380 VAC	400 VAC	420 VAC	440 VAC	460 VAC	480 VAC
15 m (50 ft)	1/0 (50)	1/0 (50)	1/0 (50)	1 (35)	1 (35)	1 (35)
30 m (100 ft)	1/0 (50)	1/0 (50)	1/0 (50)	1 (35)	1 (35)	1 (35)
46 m (150 ft)	1/0 (50)	1/0 (50)	1/0 (50)	1 (35)	1 (35)	1 (35)
61 m (200 ft)	1/0 (50)	1/0 (50)	1/0 (50)	1 (35)	1 (35)	1 (35)
76 m (250 ft)	2/0 (70)	2/0 (70)	1/0 (50)	1/0 (50)	1 (35)	1 (35)
91 m (300 ft)	3/0 (95)	3/0 (95)	2/0 (70)	2/0 (70)	1/0 (50)	1/0 (50)
107 m (350 ft)	4/0 (120)	3/0 (95)	3/0 (95)	2/0 (70)	2/0 (70)	1/0 (50)
122 m (400 ft)	250 (120)	4/0 (120)	3/0 (95)	3/0 (95)	3/0 (95)	2/0 (70)



NOTE

According to length and voltage, select the appropriate wire size. The length should consider the actual total length of feeder and sub-feeder.



NOTE

In all cases the recommended ground wire is a 1/0 (50 mm²) ground wire.

Table 12-3 Minimum Sub-Feeder Wire Size

Sub-feeder Length	Minimum Feeder Wire Size, AWG or MCM (sq. mm)/ VAC					
(A1 to PDU)	380 VAC	400 VAC	420 VAC	440 VAC	460 VAC	480 VAC
9.7536 m (32 ft)	1/0 (50)	1/0 (50)	1/0 (50)	1 (35)	1 (35)	1 (35)



NOTE

If the wire size does not match the above lists, please select the nearest wire size as per to local standards.

The information, in the three Tables listed above, assumes the use of copper wire, rated 75 C and run in steel conduit. All ampacity is determined in accordance with the *National Electrical Code (NFPA 70), Table 310-16 (2002)*. The ampacity of the circuit protection device listed above determines the minimum feeder size, except where total source regulation limits require a larger size.

NOTICE

Power feeders running under the scan room floor, as well as power vault substations under the floor, above the scan suite, or in adjacent rooms, may cause excessive EMI fields. The responsibility for meeting all site EMI requirements rests with the customer.

Ground System

The design of the CT system scanner uses an equal potential grounding system. The illustration below shows the required ground system. Three primary grounding points exist.

- A system power ground point located in the PDU.
- A reference ground point located between gantry and table base.
- A patient ground point located at the front of the table base.

The customer electrician should ground ALL patient-touchable metal surfaces to the same potential as the A1 disconnect.

Figure 12-1 System Ground Map

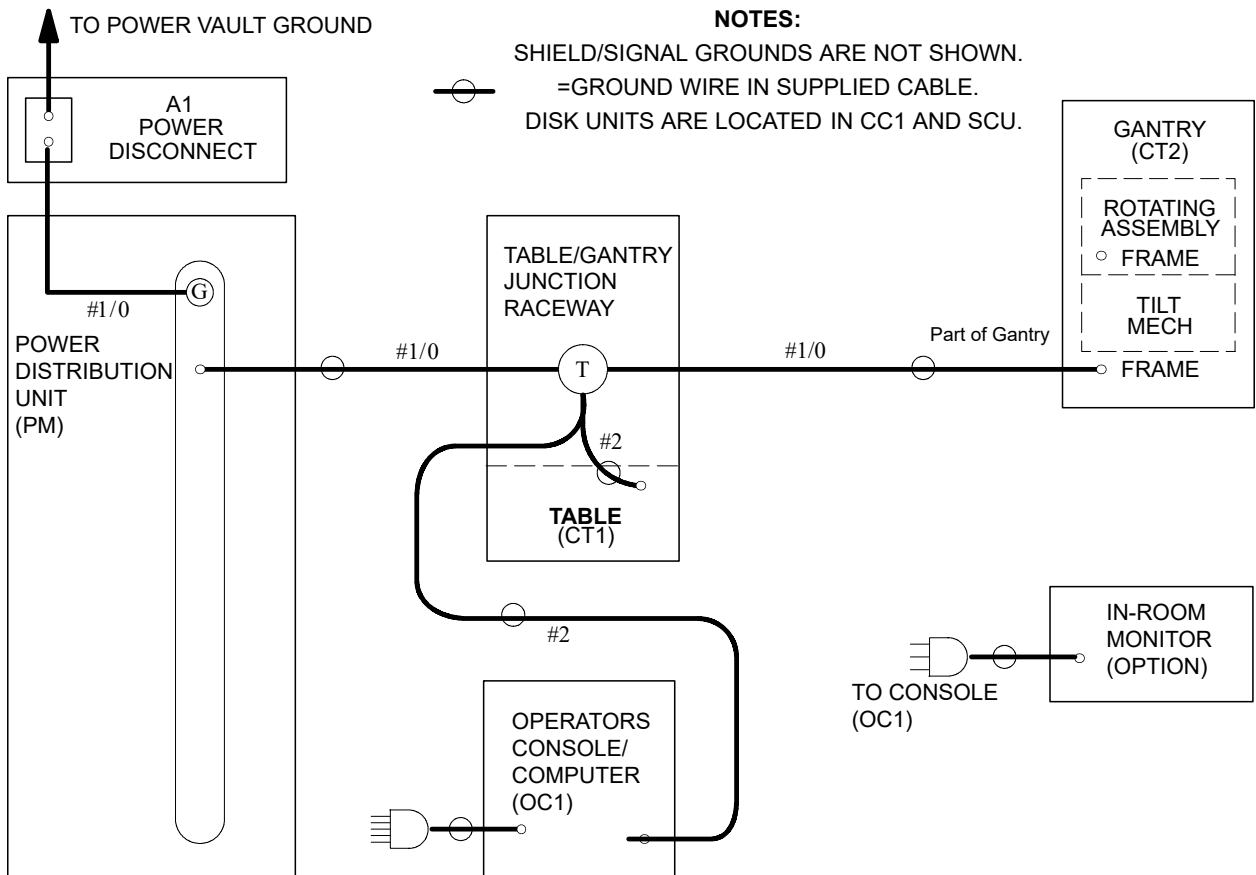

Page intentionally left blank

Chapter 13 Interconnection Data

13.1 Interconnection Data

The customer and the customer's electrical contractor should refer to the information in this section when establishing network and power interconnections for the system. In this chapter you will find the following:

- Interconnection runs for a 50/60 Hz system.
- Component designators for supplied equipment and options and wall power outlets.
- Customer installed wiring and supplied cables. The actual length of each run is less than the length of supplied cables to allow for routing inside the equipment. Cable diameters and sizes of connectors are provided to aid in sizing conduit and access plates.
- Details for the connection with the system and GE approved accessories using standard (short) length and non-standard (long) length cables, respectfully. Details appear for various types of runs, to be used when appropriate

Flush floor duct	Surface floor duct	Computer floor	Through floor duct
Through wall duct	Wall duct	Junction box	Conduit

- To minimize the need for additional junction boxes, use either a cable raceway system or a raised computer floor. CT systems use prefabricated cables with large plugs. Therefore, try to avoid conduit or pipe for cable runs.

Table 13-1 Component Designators

Designator	Applies To	Source
A1	Primary power disconnect	Contractor supplied
CT1	Patient table	System
CT2	Gantry	System
ITL	InSite telephone lines	Contractor supplied
OC1	Operator console/computer	System
PDU	Power Distribution Unit	System
SEO	System Emergency Off	Contractor supplied
SM	Slave Monitor	Option
AD	"X-Ray On" Audible Device	Contractor Supplied
WL	"X-Ray On" warning light	Contractor supplied
DS	Door Interlock Switch	Contractor supplied
BBNC	Broadband network connection	Contractor supplied

Figure 13-1 Interconnection Runs

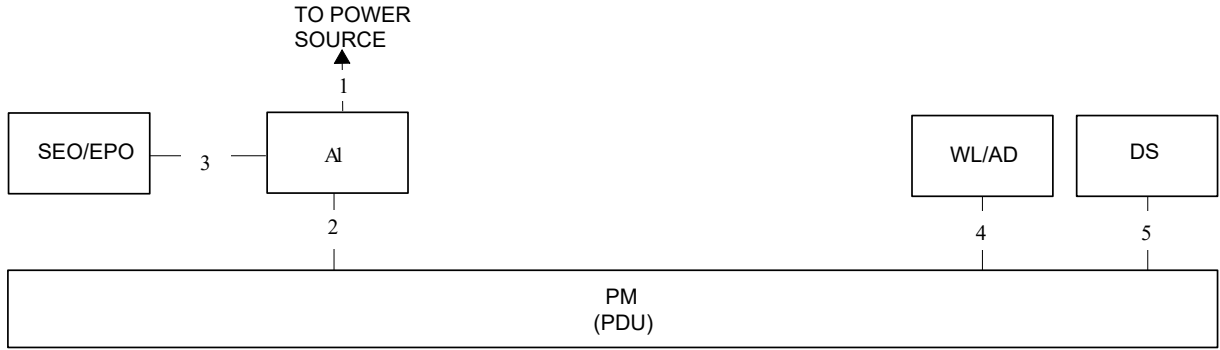

NOTES:

- 1) Used for remote diagnostics - Option
- 2) Refer to the appropriate Pre-installation / installation documents for the Laser Cameras
- 3) Category 5 cable. Use one of the following patch cords:

CAT Num	GE Part Num	Length
K9000WB	2215028-10	20 m
K9000KP	2215028-5	10 m
K9000JR	2215028-4	5 m
K9000WA	2215028-9	3 m

- 4) In order to avoid any violation of each National Regulation (NEC in USA, CCC in China, etc.), use of the compliant cable/wire is recommended. For China market, China end-user shall purchase the power supply cable that has the CCC mark

Only one phone connection is required for the system

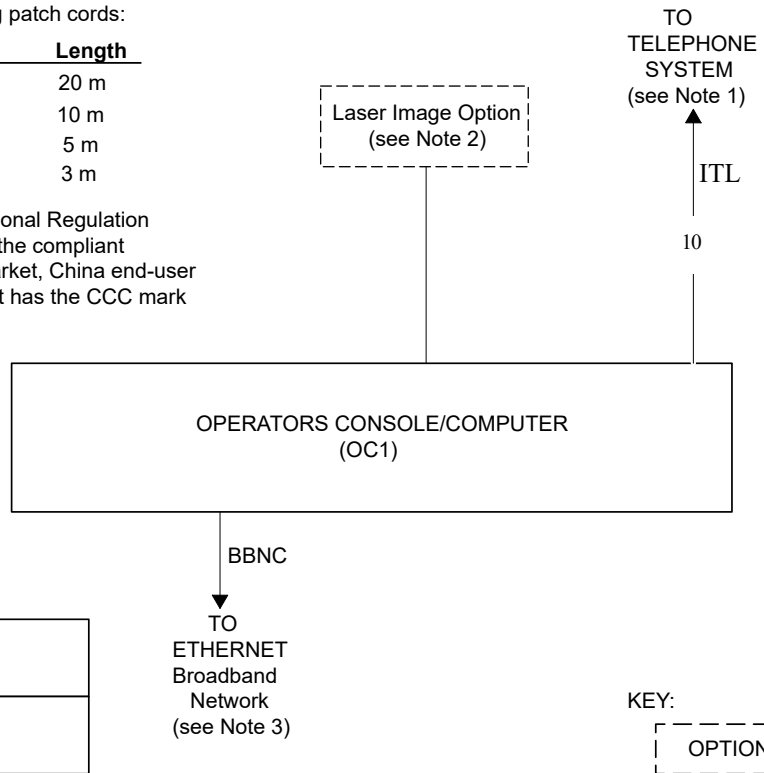

KEY:

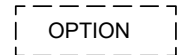

GE Healthcare Supplied (Standard Length 2281840-10)

Table 13-2 GE Healthcare-Supplied Cables (STANDARD Run) Part No/Length

Run #	Part #	Description	Length - Actual (Usable)	
			m	ft
050	2343529-2	HVDC, PDU to Gantry	9 (6)	28 (20)
051	2343530-2	HVDC, PDU to Gantry	9 (6)	28 (20)
052	2343528-2	LVAC, PDU to Gantry	9 (6)	28 (20)

Table 13-2 GE Healthcare-Supplied Cables (STANDARD Run) Part No/Length (Table continued)

Run #	Part #	Description	Length - Actual (Usable)	
			m	ft
053	5121809-2	LVAC, PDU to Console	20 (18)	65 (60)
054	n/a	LVAC, Gantry to Table		
055	2371450-2	Ground, PDU to Raceway	13 (11)	43 (35)
056	2371450-4	Ground, Raceway to Console	22 (18.3)	71 (60)
100	5120646-2	Signal, Gantry TGPU to PDU	9.9 (5)	32.5 (16.4)
101	5120645-2	Signal, Gantry TGPU to OC	21.75 (18)	71 (60)
102	2373436-3	Signal (LAN), Gantry to OC	21.75 (18)	71 (60)
103	5316594-2	Fiber Optic, Gantry to OC	20 (17)	65.5 (62.5)
104	n/a	Signal, Gantry to Table		
-	5193969-6	Signal (LAN) (includes 2 cables)	21 (18)	68 (60)
-	5169456-2	Signal, Gantry to Injector	25 (24)	84 (75)
-	5199717-2	Signal, Gantry to RPM cable	25 (24)	84 (75)

GE Healthcare Supplied (Optional, Long Run Length 2281840-9)**Table 13-3 GE Healthcare-Supplied Cables (LONG Run) Part No/Length**

Run #	Part #	Description	Length - Actual (Usable)	
			m	ft
050	2343529	HVDC, PDU to Gantry	19.35 (17)	64 (55)
051	2343530	HVDC, PDU to Gantry	25.5 (23)	84 (75)
052	2343528	LVAC, PDU to Gantry	26.35	87
053	5121809	LVAC, PDU to Console	24 (23)	80 (75)
054	n/a	LVAC, Gantry to Table	24.5 (23)	80 (75)
055	2371450	Ground, PDU to Raceway	26.35 (23)	87
056	2371450-3	Ground, Raceway to Console	19.35 (17)	64 (55)
100	5120646	Signal, Gantry TGPU to PDU	21.4 (18.4)	70 (67)
101	5120645	Signal, Gantry TGPU to OC	26.35 (24)	86 (75)
102	2373436-2	Signal (LAN), Gantry to OC	26.35 (24)	86 (75)
103	5316594	Fiber Optic, Gantry to OC	24 (21)	78.5 (70.5)
104	n/a	Signal, Gantry to Table	30.48	100
-	5193969-4	Signal (LAN) (includes 2 cables)	30.48	100
-	5169456	Signal, Gantry to Injector	30.48 (24)	100
-	5199717	Signal, Gantry to RPM cable	30.48 (29)	100

GE Healthcare Supplied (Standard Length 2281840-100)**Table 13-4 GE Healthcare-Supplied Cables (STANDARD Run) Part No/Length**

Run #	Part #	Description	Length - Actual (Usable)
-------	--------	-------------	--------------------------

Table 13-4 GE Healthcare-Supplied Cables (STANDARD Run) Part No/Length (Table continued)

			m	ft
050	2343529-2	HVDC, PDU to Gantry	9 (6)	28 (20)
051	2343530-2	HVDC, PDU to Gantry	9 (6)	28 (20)
052	2343528-2	LVAC, PDU to Gantry	9 (6)	28 (20)
053	2343531-2	LVAC, PDU to Console	20 (18)	65 (60)
054	n/a	LVAC, Gantry to Table		
055	2371450-2	Ground, PDU to Raceway	13 (11)	43 (35)
056	2371450-4	Ground, Raceway to Console	22 (18.3)	71 (60)
100	5120646-2	Signal, Gantry TGPU to PDU	9.9 (5)	32.5 (16.4)
101	5120645-2	Signal, Gantry TGPU to OC	21.75 (18)	71 (60)
102	2373436-3	Signal (LAN), Gantry to OC	21.75 (18)	71 (60)
103	5316594-2	Fiber Optic, Gantry to OC	20 (17)	65.5 (62.5)
104	n/a	Signal, Gantry to Table		
-	5193969-6	Signal (LAN) (includes 2 cables)	21 (18)	68 (60)
-	5419978-2	Signal, Gantry to Injector	25 (24)	84 (75)

GE Healthcare Supplied (Optional, Long Run Length 2281840-101)**Table 13-5 GE Healthcare-Supplied Cables (LONG Run) Part No/Length**

Run #	Part #	Description	Length - Actual (Usable)	
			m	ft
050	2343529	HVDC, PDU to Gantry	19.35 (17)	64 (55)
051	2343530	HVDC, PDU to Gantry	25.5 (23)	84 (75)
052	2343528	LVAC, PDU to Gantry	26.35	87
053	2343531	LVAC, PDU to Console	24 (23)	80 (75)
054	n/a	LVAC, Gantry to Table	24.5 (23)	80 (75)
055	2371450	Ground, PDU to Raceway	26.35 (23)	87
056	2371450-3	Ground, Raceway to Console	19.35 (17)	64 (55)
100	5120646	Signal, Gantry TGPU to PDU	21.4 (18.4)	70 (67)
101	5120645	Signal, Gantry TGPU to OC	26.35 (24)	86 (75)
102	2373436-2	Signal (LAN), Gantry to OC	26.35 (24)	86 (75)
103	5316594	Fiber Optic, Gantry to OC	24 (21)	78.5 (70.5)
104	n/a	Signal, Gantry to Table	30.48	100
-	5193969-4	Signal (LAN) (includes 2 cables)	30.48	100
-	5419978	Signal, Gantry to Injector	30.48 (24)	100

GE Healthcare Supplied (Standard Length 2281840-102)**Table 13-6 GE Healthcare-Supplied Cables (STANDARD Run) Part No/Length**

Run #	Part #	Description	Length - Actual (Usable)
-------	--------	-------------	--------------------------

Table 13-6 GE Healthcare-Supplied Cables (STANDARD Run) Part No/Length (Table continued)

			m	ft
050	2343529-2	HVDC, PDU to Gantry	9 (6)	28 (20)
051	2343530-2	HVDC, PDU to Gantry	9 (6)	28 (20)
052	2343528-4	LVAC, PDU to Gantry	9 (6)	28 (20)
053	2343531-2	LVAC, PDU to Console	20 (18)	65 (60)
054	n/a	LVAC, Gantry to Table		
055	2371450-2	Ground, PDU to Raceway	13 (11)	43 (35)
056	2371450-4	Ground, Raceway to Console	22 (18.3)	71 (60)
100	5419992-2	Signal, Gantry TGPU to PDU	9.9 (5)	32.5 (16.4)
101	5419981-2	Signal, Gantry TGPU to OC	21.75 (18)	71 (60)
102	2373436-3	Signal (LAN), Gantry to OC	21.75 (18)	71 (60)
103	5334833	Fiber Optic, Gantry to OC	20 (17)	65.5 (62.5)
104	n/a	Signal, Gantry to Table		
-	5193969-6	Signal (LAN) (includes 2 cables)	21 (18)	68 (60)
-	5419978-2	Signal, Gantry to Injector	25 (24)	84 (75)

GE Healthcare Supplied (Optional, Long Run Length 2281840-103)**Table 13-7 GE Healthcare-Supplied Cables (LONG Run) Part No/Length**

Run #	Part #	Description	Length - Actual (Usable)	
			m	ft
050	2343529	HVDC, PDU to Gantry	19.35 (17)	64 (55)
051	2343530	HVDC, PDU to Gantry	25.5 (23)	84 (75)
052	2343528-3	LVAC, PDU to Gantry	26.35	87
053	2343531	LVAC, PDU to Console	24 (23)	80 (75)
054	n/a	LVAC, Gantry to Table	24.5 (23)	80 (75)
055	2371450	Ground, PDU to Raceway	26.35 (23)	87
056	2371450-3	Ground, Raceway to Console	19.35 (17)	64 (55)
100	5419992	Signal, Gantry TGPU to PDU	21.4 (18.4)	70 (67)
101	5419981	Signal, Gantry TGPU to OC	26.35 (24)	86 (75)
102	2373436-2	Signal (LAN), Gantry to OC	26.35 (24)	86 (75)
103	5334833	Fiber Optic, Gantry to OC	24 (21)	78.5 (70.5)
104	n/a	Signal, Gantry to Table	30.48	100
-	5193969-4	Signal (LAN) (includes 2 cables)	30.48	100
-	5419978	Signal, Gantry to Injector	30.48 (24)	100

GE Healthcare Supplied (Optional, Long Run Length for GOC6 Series Consoles)

- These extension cables shall not be run through a walls, ceilings, floors, plenums or ducts between rooms. Some are not fire rated for that type of use.

- These cable are meant to relocate the operator devices (GSCB, keyboard, Monitors, Mouse, Trackball and Barcode Reader) to a different desktop location within the same room.
- The distance from the actual cable connection within the console to the top opening of the rear console cover is approximately 19 inches.
- The “Usable Length” will be reduced based on the actual distance from the point where the cables appear on the alternate desktop to the actual position of the devices in front of the operator. This distance must be taken into consideration during the design of any permanent alternate desktop. The estimated average extended distance between the console and the operator devices (GSCB, Keyboard, Monitors, Mouse, Trackball and Barcode Reader) is 2.0 meters (6.5 feet).
- The MOD unit must remain on or near the Console Table Top (See cable length below).

Table 13-8 GE Healthcare-Supplied Cables (Console LONG Run) Part No/Length

Run #	Part #	Description	Length - Actual (Usable-Approx)	
			m	ft
N/A	5455883	SCSI extension cable for SCIM	5.0 (4.7)	16.4 (15.0)
N/A	5458246	Monitor Video cable DVI-VGA	5.0 (4.7)	16.4 (15.0)
N/A	5431912	Monitor video cable from DP to DVI	5.0 (4.7)	16.4 (15.0)
N/A	5450275	PS2 extension cable for mouse	3.5 (3.0)	11.4 (10.0)
N/a	5431911	USB extension cable for Barcode reader	3.0 (2.5)	9.8 (8.2)
N/A	5443978	USB extension cable for Peripheral Media Tower (PMT)	3.0 (2.5)	9.8 (8.2)
N/A	5431910	USB extension cable for Trackball	3.0 (2.5)	9.8 (8.2)
N/A	5431909	USB extension cable for keyboard	3.0 (2.5)	9.8 (8.2)
N/A	5443978-2	USB extension cable for external hard drive (Accessory)	3.0 (2.5)	9.8 (8.2)
N/A	5443978-3	USB extension cable for DVD RAM	3.0 (2.5)	9.8 (8.2)
N/A	5315013-5	Power Cable for Magneto-Optical Disk drive (MOD)*	1.5	4.9
N/A	5389625-2	Long Power cable for PMT, Real In One Console (RIO)	5.0 (4.7)	16.4 (15.0)
N/A	5389625-3	Long Power cable for Right Monitor, RIO Console	5.0 (4.7)	16.4 (15.0)
N/A	5389625-4	Long Power cable for Left Monitor, RIO Console	5.0 (4.7)	16.4 (15.0)

**NOTE**

* MOD must stay on or near Console Table Top due to cable length.

Table 13-9 GE Healthcare-Supplied Cable Information

Description	UL Cable Information								Pull Size mm (in)
	UL Style	Flam. Rating	Voltage Rating	Voltage Actual	Temp. Rating (C)	Diameter mm (in)	# of Cond	Size AWG	
HVDC, PDU to Gantry	2587	FT4	600	+&-350VDC	90	19 (0.751)	3	(2) 4 (1) 8	22 (0.87) Dia
HVDC, PDU to Gantry	2587	FT4	600	440Y/254	90	15 (0.604)	4	14	11 (0.44) Dia
LVAC, PDU to Gantry	2587	FT4	600	120/208Y	90	14 (0.542)	5	8	56 (2.22) Dia
LVAC, PDU to Console	2587	FT4	600	120VAC	90	12 (0.483)	4	10	56 (2.22) Dia
LVAC, Gantry to Table	1015		600	120VAC			3	14	
Ground, PDU to Raceway	1284	VW-1 (FT-1)	600	0	105	16 (0.608)	1	1/0	16 (0.62) Dia
Ground, Raceway to Console	1283	VW-1 (FT-1)	600	0	105	12 (0.467)	1	2	12 (0.48) Dia
Signal, Gantry TGPU to PDU		FT4	300	<30VDC	80	11 (0.440)	25	22	17 X 58 (0.68 X 2.30) 19 X 51 (0.75 X 2.01)
Signal, Gantry TGPU to OC		FT4	300	<30VDC	80	11 (0.440)	25	22	17 X 58 (0.68 X 2.30) 19 X 51 (0.75 X 2.01)
Signal (LAN), Gantry to OC			1900	<30VDC		6 (0.234)	8	24	15 (0.59) Dia
Fiber Optic, Gantry to OC			n/a	n/a			1	n/a	10 (0.39) Dia
Signal, Gantry to Table		FT4	300		80		25	22	
Signal (LAN) (includes 2 cables)			1900	<30VDC		6 (0.234)	8	24	15 (0.59) Dia
Signal, Gantry to Injector		FT4	300	<30VDC	80	11 (0.440)	25	22	17 X 58 (0.68 X 2.30) 19 X 51 (0.75 X 2.01)
Signal, Gantry to RPM cable		FT4	300	<30VDC	80	11 (0.440)	25	22	17 X 58 (0.68 X 2.30) 19 X 51 (0.75 X 2.01)

Table 13-10 GE Healthcare-Supplied Cables (Console LONG Run) Part No/Length

Description	UL Cable Information								Pull Size mm (in)
	UL Style	Flam. Rating	Voltage Rating	Voltage Actual	Temp. Rating (C)	Diameter mm (in)	# of Cond	Size AWG	
SCSI extension cable for SCIM	2027 6	FT-4 VW-1 CL2 CMG	30V	12V	80	10 (0.394)	50	30	N/A

Table 13-10 GE Healthcare-Supplied Cables (Console LONG Run) Part No/Length (Table continued)

Monitor Video cable DVI-VGA	2027 6	FT-4 VW-1 CL2 CMG	30V	12V	80	8 (0.315)	9	(3 Coax) 28 (6) 28	N/A
Monitor video cable from DP to DVI	2027 6	FT-4 VW-1 CL2 CMG	30V	12V	80	8 (0.315)	14	28	N/A
PS2 extension cable for mouse	2464	FT-4 CMG	300V	5V	80	5.3 (0.209)	6	(2) 28	N/A
USB extension cable for Barcode reader	CM	FT-4 CM CMG	30V	5V	75	5.0 (0.197)	4	(2) 28 (2) 20	N/A
USB extension cable for Peripheral Media Tower (PMT)	CM	FT-4 CM CMG	30V	5V	75	5.0 (0.197)	4	(2) 28 (2) 20	N/A
USB extension cable for Trackball	CM	FT-4 CM CMG	30V	5V	75	5.0 (0.197)	4	(2) 28 (2) 20	N/A
USB extension cable for keyboard	CM	FT-4 CM CMG	30V	5V	75	5.0 (0.197)	4	(2) 28 (2) 20	N/A
USB extension cable for external hard drive (Accessory)	CM	FT-4 CM CMG	30V	5V	75	5.0 (0.197)	4	(2) 28 (2) 20	N/A
USB extension cable for DVD RAM	CM	FT-4 CM CMG	30V	5V	75	5.0 (0.197)	4	(2) 28 (2) 20	N/A
Power Cable for Magneto-Optical Disk drive (MOD)*	SJT W	FT-2 VW-1 SJTW	300V	110V	105	7.9 (0.311)	3	(3) 18	N/A
Long Power cable for PMT, Real In One Console (RIO)	SJT W	FT-2 VW-1 SJTW	300V	110V	105	7.9 (0.311)	3	(3) 18	N/A
Long Power cable for Right Monitor, RIO Console	SJT W	FT-2 VW-1 SJTW	300V	110V	105	7.9 (0.311)	3	(3) 18	N/A
Long Power cable for Left Monitor, RIO Console	SJT W	FT-2 VW-1 SJTW	300V	110V	105	7.9 (0.311)	3	(3) 18	N/A

Contractor/Customer Supplied Runs

Table 13-11 Runs 1, 2, 3, 4, and 5 Connections

Customer Installed Wiring		Description	Wire and Cable Pigtails m (ft)		Cables Supplied (Customer to complete table)	Plug Pulling Dimensions (Customer to complete table)
Qty	Size AWG (mm ²)		From	To		
RUN NO. 1 FROM PRIMARY POWER SOURCE TO FACILITY DISCONNECT (POWER SOURCE - A1/MDP)						
 NOTE The primary power ground to A1/MDP disconnect must meet local codes, in all cases the recommended ground wire is a 1/0 (50 mm ²) ground wire.						
Maximum Run Length *						
3	*	POWER	1 (3)	1 (3)		
1	1/0 (50)	GROUND	1 (3)	1 (3)		
RUN NO. 2 FROM FACILITY DISCONNECT TO POWER DISTRIBUTION UNIT (A1 - PM)						
Maximum Run Length *						
3	*	POWER	1 (3)	1 (3)		
1	1/0 (50)	GROUND	1 (3)	1 (3)		
-	-	NEUTRAL - not required	1 (3)	1 (3)		
RUN NO. 3						
FROM FACILITY DISCONNECT TO SYSTEM EMERGENCY OFF (A1 - SEO)						
2	14 (2.5)	POWER	2 (6)	2 (6)		
1	14 (2.5)	GROUND	2 (6)	2 (6)		
BEVCO PANEL - FROM FACILITY DISCONNECT TO EMERGENCY POWER OFF (A1 - EPO)						
2	14 (2.5)	Partial UPS EPO Circuit	2 (6)	2 (6)		
2	14 (2.5)	Facility Disconnect EPO Circuit	2 (6)	2 (6)		
1	14 (2.5)	GROUND	2 (6)	2 (6)		
RUN NO. 4 POWER DISTRIBUTION UNIT TO WARNING LIGHT CONTROL (PDU - WL)						
2	14 (2.5)	WARNING LIGHT OR AUDIBLE DE-VICE (See Note 1)				
		CONTROL TS6 1, 2, 3, 4, 5, 6, 7, 8				
RUN NO. 5 POWER DISTRIBUTION UNIT TO SCAN ROOM DOOR INTERLOCK (PDU - DOOR SWITCH)						
2	14 (2.5)	SCAN ROOM DOOR INTER LOCK TS6 9, 10				
RUN NO. n/a BBNC						
1	customer determined	Hospital Broadband Network Connection (Wall Jack: Placed on the wall behind the console.)				
* Refer to Table <i>Minimum Feeder Wire Size</i> in Chapter Power Requirements for AWG (mm ²) wire sizes.						
Note 1: Input voltage may vary based on local regulatory codes. Minimum Input voltage: 24 VAC Maximum Input Voltage: 125VAC at 10amps.						

Table 13-12 Contractor Supplied Components

Reference	Associated Equipment	Material/Labor Supplied by Customer Contractor	USA Vendor/CAT No. GE Catalog
A1 380 - 480 V 50/60 Hz	Circuit Breaker with Magnetic Contactor	Three Pole, 380 - 480 V, Combination breaker with magnetic contactor. Includes control transformer, optional UPS interface, ON/OFF controls and auto-restart feature, if GE supplied.	Recommend*: <ul style="list-style-type: none"> E4502AE / E4502BE (125A) E4502AF / E4502BF (150A) Optional remote operator control available from GE Supply, Cat # GESCTROCS1
BBNC (strongly recommended)	Broadband Network Connection	Broadband network connection wall jack, located within 1 m (39 in) of the operator console location, for internal hospital networking and InSite Broadband connectivity. Cabling to conform to facility's IT standards.	
ITL (optional)	In-Suite Telephone Lines	Supply two (2) voice-grade telephone lines. One line must be a direct number from outside the facility—do not route this line through a telephone switchboard. Telephone line operating charges are paid by the customer.	
	System Components	Reference the system installation drawings supplied by Installation Support Services within your geographic area. Room Warning Light Controller	E4500AM
* Refer to the A1 UPS Table in Section 4 of this chapter.			

UPS Wiring Cables

Table 13-13 UPS Wiring Cables Part No/Length

Run #	Part #	Description	Length - Actual (Usable)	
			m	ft
Standard	060	PDU to UPS	6 (5)	19 (15)
	061	UPS to PDU	6 (5)	19 (15)
	110	A1 to UPS	13.7 (12.7)	45 (40)

Table 13-14 UPS Wiring Cable - UL Information

Description	UL Cable Information								Pull Size mm (in)
	UL Style	Flam. Rating	Voltage Rating	Voltage Actual	Temp. Rating (C)	Diameter mm (in)	# of Cond	Size AWG	
PDU to UPS	2587	FT4	600	+& -350VDC	90	19 (0.751)	3	4	22 (0.87) Dia
UPS to PDU	2587	FT4	600	440Y/254	90	15 (0.604)	4	14	22 (0.87) Dia
A1 to UPS	2587	FT4	600	208Y/120	90	14 (0.542)	5	8	25 (1.0) Dia

A1 UPS

PDU Type & Model No.		NGPDU-61 2326492-61
Maximum Mom. kVA Rating		150 kVA
Required Main Disconnect (A1) Catalog No.	Europe (400V)	E45021BC (50Hz 160A) (includes Auto Restart & Integrated UPS Control) (Additional A1 Disconnects available for Europe through the European Sales Team.)
	Global except EMEA (380-420V)	E4502AF / E4502BF (50-60Hz 150A) (includes Auto Restart & Integrated UPS Control)
	Global except EMEA (440-480V)	E4502AE / E4502BE (50-60Hz 125A) (includes Auto Restart & Integrated UPS Control)
Optional Partial UPS Kit Catalog No.		E4502F (for US) Eaton 14.4 KVA 3-Phase Partial System UPS REQUIRES on of the A1 Panels shown above or equal. B7864PZ (for Global) PowerWare 9355-15-14GE (14.4 kVa - 40A) REQUIRES on of the A1 Panels shown above or equal.

Primary Power Disconnect

Requires LOTO compatible disconnect to install this system.

If a UPS is required, a GE Disconnect is strongly recommended for safe operation. The GE disconnect and UPS are designed to work together.

Details refer to DOC2058932 on SIMS Content Viewer. This is a restricted file, contact your PMI for specific questions or concerns.

Scan Room Warning Light and Door Interlock

Figure 13-2 TS6 X-Ray Warning Light Connections

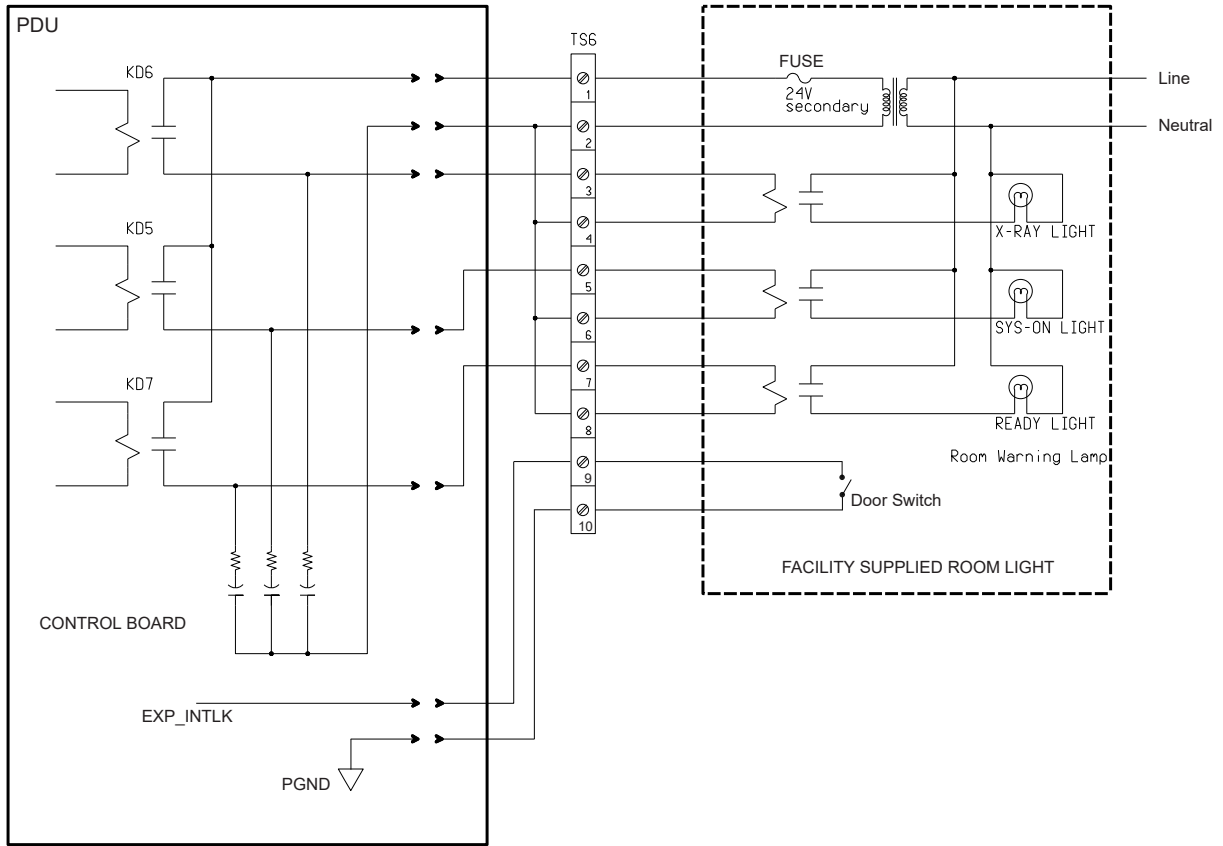
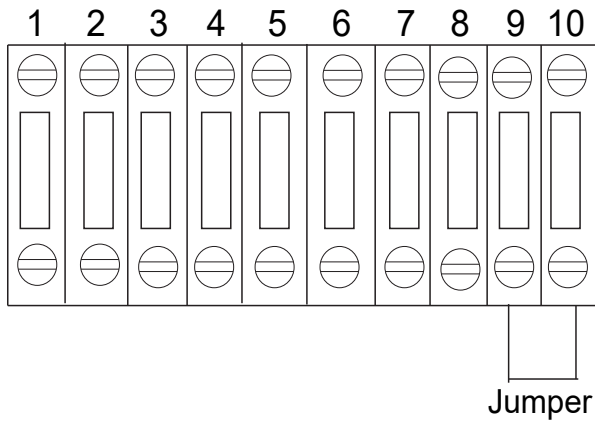

Figure 13-3 TS6 Room Door Interlock Connections - Without a Door Interlock



If not using a door switch, add a jumper.

If jumper is not in place, exposures will not be made. Check this jumper if you get scan interlock errors.

Figure 13-4 TS6 Room Door Interlock Connections - With a Door Interlock

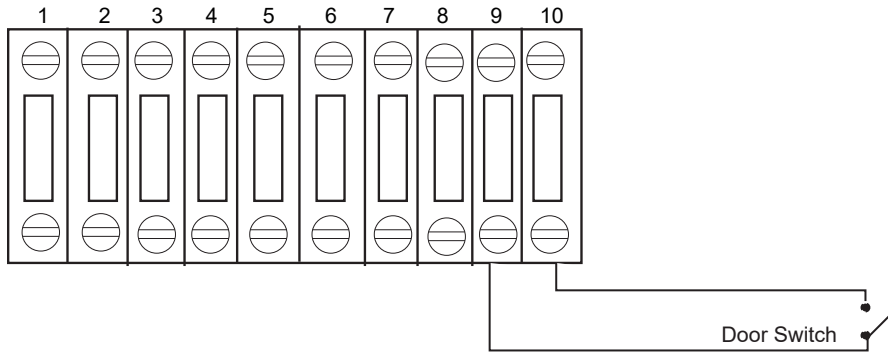

Page intentionally left blank

Chapter 14 Delivery and Storage Requirements

14.1 Delivery and Storage Requirements

This chapter provides information necessary for planning a safe and successful delivery of the CT system from GE Healthcare to the receiving area of the installation site, and from the receiving area of that facility to the scan suite.

Your PM will determine the most appropriate means of transporting the system to your facility. However, the type of receiving area at the facility where the installation will occur determines, to a large extent, the method used to transport the system to that facility. When planning for delivery, facilities fall into two general categories: those with a loading dock, and those without a loading dock.

LOADING DOCK DELIVERIES Facilities with a loading dock in their receiving area can generally accommodate delivery of the system by van. This is the preferred method of transporting the system to the installation site, as dock-to-dock shipment by van minimizes the possibility of dropping the gantry. Also, packing the CT system for van shipment involves minimum tear-down of components. This system is shipped Lean packed on pallets and dollies with approximately 10 units.

GROUND (NON-LOADING DOCK) DELIVERIES Facilities without a loading dock usually require ground delivery by either lift-gate or appropriately sized forklift. Such deliveries require unloading the system components from the truck and then rolling them across smooth sidewalks or other paved surfaces into the facility.

- **Lift-gate Truck** Delivery of the system by lift-gate truck requires an appropriate capacity truck with a lift-gate capable of lifting 3 tons. If using a roll back truck, the PM should be on-site at the time of delivery to supervise this operation in person.
- **Tilt-bed Truck - NOT Approved** Delivery of the system by tilt-bed truck is no longer an approved delivery method due to EHS safety risks of tipping the system over. If a loading dock is not available, then a Fork-lift truck shall instead be used.
- **Fork-lift Truck**



NOTE

The tines on the fork truck need to be a minimum of 8' long in order to pick the gantry on the lifting skid past the center point of gravity.

A fork-lift can be used to unload the gantry, provided that the *lifting option* is ordered and delivered. The system will arrive with a lifting skid attached to the gantry and table. This option cannot be added later as an on-site addition.

Delivery to the Scan Suite

Once at the installation site, conveyance of the system into the scan suite may involve special considerations, such as vertical lifting, or transportation through stairwells, which involves additional planning by the PM.

Lifting

Both vertical and horizontal lifting require professional riggers.

If delivery requires horizontal lifting, the PMI should contact with CT engineering team with installation concession.

If delivery requires vertical lifting and deviates from the requirement outlined in the PIM then engineering must be contacted for approval.

Stairway Deliveries Stairways with angles at or less than 45 degrees can accommodate delivery of system components. If the site requires delivery through stairwells, the PM adds the appropriate identifier to the order to ensure proper packaging of the system, and notifies CT engineering before attempting the procedure. The components ship attached to special lifting skids with lifting instruction for riggers.

Rigging

The CT gantry assemblies shall not be lifted by their dollies. The CT gantry assemblies shall not be transported across any surface by any means other than the dollies provided by GE. The CT gantry assemblies have no lifting points on them and are not designed to be lifted by any special rigging attached to the gantry assemblies themselves.



DANGER



POSSIBLE SEVERE PERSONAL INJURY OR DEATH.

The dollies are not designed to be used as an attachment point for any method of lifting the subsystems.

attaching lifting straps, cables or mechanisms to the dolly handles or any other part of the dolly is strictly prohibited.

NOTICE

If it is determined that the subsystems must be lifted by crane or other lifting method the PM or person responsible for local siting of the system shall NOT proceed with the installation without consulting directly with GE Engineering.

Lifting the subsystems by crane or other lifting method should always be avoided. All alternate methods of delivery should be evaluated including the removal of any obstructions, doorways, walls, and windows.

If lifting is still required:

1. The entire gantry assembly and both gantry transport side dollies must be placed on a lifting platform. GE does not provide a lifting platform.

The Stationary Assembly shall be lowered to its transport position with the gantry base in contact with the platform. The Rotating Assembly shall be lowered to its transport position resting on the dolly transport pads in contact with the platform.



NOTE

If the platform has limited space, the gantry transport side dollies may be removed during the lift. Once the lift is completed, the gantry transport side dollies must be installed back on the gantry assembly.

2. The entire patient table must be on its dollies and lifted while sitting on a lifting platform.
The patient table on its dolly shall be lowered to its transport position so the table base is in contact with the platform.
3. The platform must be designed such that no lifting straps or cables come in contact with any part of the gantry or table subsystems or its side dollies.
4. The lifting platform shall bear the entire load. No part of the subsystem shall bear any load during the lift.

**NOTE**

If delivery requires vertical or horizontal lifting, the PM needs to add the necessary identifier to the order.

Floor Protection GE recommends floor protection along the delivery path from the dock/receiving area to the scan room.

Unloading and unpacking the System Retain the packaging surrounding the Console and the UPS. Both are shipped on a shock resistant skid. DO NOT REMOVE THE SKID.

Dollies

Shipments within the United States Typically domestic shipments involve the use of dollies for moving the gantry, table and operator console. After completing the installation, return the dollies to GE using the shipping document found in Box #1.

Shipments outside of the United States For shipments made outside the United States, customers may purchase dollies (B7850LD). After removing the system from the crates, DO NOT return the dollies shipped outside of the US to GE Healthcare in Milwaukee, WI USA. Instead, forward them to the local GE office or warehouse. Zero Clearance and Tilting Table dollies can be purchased through UMI. To buy dollies, go to: <http://www.umi-dollyshop.com>.

Zero Clearance Dollies Deliveries involving small elevators with a depth of at least 2692 mm (106 in) require zero clearance dollies. Zero clearance dollies allow movement of the gantry in tight areas. Avoid using them for normal dock or van deliveries. To buy dollies, go to: <http://www.umi-dollyshop.com>.

Tilting Table Dollies Deliveries involving small elevators with a depth of at least 2438 mm (96 in) require tilting table dollies. If storing the system prior to installation, do not order tilt dollies. If you are unable to obtain tilt dollies for delivery, substitute riggers in their place. A limited number of tilt dollies exist for U.S. deliveries. To order dollies, go to: <http://www.umi-dollyshop.com>.

Gantry Delivery Considerations

Gantry Shipping State The gantry ships with most covers installed, and the assembly mounted between two dollies. Two side rails, bolted to the dollies, stabilize the dollies and protect the gantry. Use the dolly elevating casters to lift the gantry off its base and roll it into position.

Figure 14-1 Gantry with Shipping Dollies and Side Rails

Door Openings Unobstructed door openings, for moving equipment into the building, must measure 1067 X 2083 mm (42 X 82 in) minimum. Routing through corridors with a width of 2439 mm (8 ft) also prove helpful.

Elevator Requirements When moving the gantry from the receiving location to the scanning room, pay special attention to elevator size and capacity. Removing side rails and one dolly after placing the gantry in the elevator reduces the gantry width/length and elevator requirements.

Due to gantry component weight differences all weights listed here are averages. This difference can measure ± 18.14 kg (± 40 lb). Contact the elevator manufacturer if the gantry weight exceeds elevator capacity.

Table 14-1 Size of Gantry and Dollies, with and without Side Rails

Configuration	Length	Width	Height	Weight
Dollies ON, Side Rails ON	2900 mm (114 in)	1290 mm (51 in)	2000 mm (79 in)	1932 kg (4260 lb)
Dollies ON, Side Rails OFF	2900 mm (114 in)	1000 mm (39.4 in)	2000 mm (79 in)	1910 kg (4210 lb)
Dollies OFF, Covers OFF	2060 mm (81 in)	860 mm (34 in)	1850 mm (73 in)	1568 kg (3457 lb)
The minimum hallway and door size for a gantry with covers and dollies attached but side rails removed, is 1016 mm (40 in).				

**NOTE**

For alternative lifting arrangements and instructions, contact GE Installation Support Services.

Table Delivery Considerations

The table ships without side covers installed. Covers ship in four separate boxes; the table ships mounted between two dollies. Table shipping dimensions are 3200 mm (126 in) long; 650 mm (25.6 in) wide, and 1200 mm (47.2 in) high.

Table 14-2 Table Dimensions with/without Dollies

Description	Length	Width	Height	Weight
VT2000 / VT2000X Table				
without Dollies	2997 mm (118 in)	660 mm (26 in)	889 mm (35 in)	505 kg (1113 lb)
with Dollies	2997 mm (118 in)	762 mm (30 in)	1143 mm (45 in)	632 kg (1392 lb)
with Tilting Dollies (approx. dimensions)	2489-2921 mm 98 - 115 in)	660 mm (26 in)	1778-2032 mm 70-80 in	636 kg (1401 lb)
VT1700 Table				
without Dollies	2489 mm (98 in)	660 mm (26 in)	889 mm (35 in)	475 kg (1047 lb)
with Dollies	2489 mm (98 in)	762 mm (30 in)	1143 mm (45 in)	602 kg (1326 lb)
Dollies Dimension				
All Tables	210 mm (87 in)	762 mm (30 in)	127 mm (5 in)	132 kg (291 lb)
Tilting Dollies Dimension				
VT2000 / VT2000X Tilting Dollies	762 mm (30 in)	762 mm (30 in)	889 mm (35 in)	136 kg (300 lb)
VT1700 Tilting Dollies	762 mm (30 in)	762 mm (30 in)	889 mm (35 in)	132 kg (291 lb)

Console Delivery Consideration

The operator console ships without the keyboard table installed. The keyboard table ships with the operator console, which is shipped on a skid equipped with ramps for unloading. Do not remove the console from the shipping skid unit it is in the CT equipment room.

Table 14-3 GOC6.6 Console Shipping Dimensions

	Depth	Width	Height
Console with keyboard table on shipping skid.	1016 mm (40 in)	1346 mm (53 in)	1041 mm (41 in)
Console alone as shipped without skid.	888 mm (35 in)	1238 mm (49 in)	750 mm (30 in)

Table 14-4 NIOHD64 Console Shipping Dimensions

	Depth	Width	Height
Console with package	1016 mm (40 in)	1346 mm (53 in)	1041 mm (41 in)
Console alone as shipped	738 mm (29 in)	470 mm (19 in)	655 mm (26 in)

Table 14-5 Open Console Shipping Dimensions

	Depth	Width	Height
Console with package	890 mm (35 in)	590 mm (23 in)	780 mm (31 in)
Console alone as shipped	672 mm (26 in)	400 mm (16 in)	576 mm (23 in)

NOTICE

Do not lift the operator console by the monitor table top to remove it from the shipping skid.

Figure 14-2 Console on skid with ramps exposed for unloading



Storage Requirements

NOTICE

FAILURE TO ADHERE TO STORAGE REQUIREMENTS CAN RESULT IN EQUIPMENT DAMAGE.

Short Term Storage (Less than Six Months) If storing the CT system before installation for less than six months, store it in a temperature and humidity controlled warehouse. Protect it from weather, dirt, and dust. Meeting the following requirements prevents rust and corrosion from forming on bearing surfaces due to condensation:

- Storage temperature should not exceed 0 - 30° C (32 - 86° F)
- Maximum relative humidity (non-condensing) of the environment in which the system is stored is 70%.
- Maximum rate of relative humidity change measures 5% / hr.
- Maximum rate of temperature change measures 3° C / hr (5° F / hr).
- Storage longer than 6 months is not recommended.

NOTICE

Between delivery qualifies as short term storage. Van storage must meet the same specifications listed above.

Construction Site Storage When storing the CT system at a construction site do not damage or puncture the shipping crate. Keep unit in tact. Do not remove packaging until all construction is completed at the site and all dust created by the construction is removed.

- Maintain a storage temperature within the range of 10 - 32° C (50 - 90° F).
- Maintain a relative humidity (non-condensing) between 20 - 70%.

Extreme Temperature Delivery

Avoid extreme temperature during system transportation and delivery. Extreme temperatures consist of temperatures below -18° C (0° F), or above 49° C (120° F), without humidity control. When transporting the CT system, prevent extended exposure of the system to temperatures or humidity out of the following specifications:

- Temperature: -40° to +70° C (-40° to +158° F)
- Humidity: 10% to 100%

NOTICE

Component freezing occurs when exposing the CT system to temperatures below -18° C (0° F) for a period longer than two (2) days. **Allow a minimum of 12 hours for the CT system to adjust to ambient room temperature prior to installation.** Failure to adhere to extreme temperature requirements during delivery and storage can result in equipment damage.

Page intentionally left blank

Chapter 15 Handling Requirements

15.1 Handling Requirements

Communicate the information in this chapter to any personnel who will transport, move or otherwise handle the system components during transportation and delivery of the system.

Transportation

To avoid dropping the gantry, it is recommended that the system is transported from GE Healthcare to the facility of the installation site, shipping dock-to-dock in a van. However, facilities without a loading dock may transport the system using lift-gate or flatbed trucks, provided that no dropping or mishandling of the system occurs. These methods involve unloading system components from the truck and then rolling them across SMOOTH sidewalks or other paved surfaces.

Handling Requirements

The design of the CT system does not tolerate dropping, shock, vibration, tipping, or hoisting. Be sure to communicate these handling requirement to all parties involved in transporting, moving, and handling system components.

- **Avoid Dropping**

Never drop the gantry, console, table, or PDU. A drop from a height greater than 13 mm (0.5 in) may cause structural damage to the frame or other major components. Damage resulting from a drop (e.g. bent frame, misalignment) may not become apparent until after the system is installed.

- **Avoid Shocks and Vibrations**

The design of the CT system, including gantry, console, table and PDU, does not tolerate excessive shock or vibration, which may occur during unloading. For example, rolling the console across a “washboard” style ramp may vibrate components, causing loose or broken connections. Damage resulting from shock, vibration (e.g. monitor, CD-ROM, hard-drive, or console failure) may not be evident until after the system is installed.

- **Avoid Tipping**

All system components must remain upright at all times; avoid tipping them. Move the gantry by rolling it on the dollies only, do not hoist it. Avoid tipping or lifting the gantry when moving it through hallways doorways, elevators, etc.

NOTICE

Never lift the gantry with a forklift. Lifting the gantry requires engineering approval for each occurrence. Your GE PM should contact CT Engineering for all special lifting requirements, as unauthorized gantry lifting can cause gantry bearing damage.

- **Flat-bed Truck Removal (NOT Approved Tilting)**

Flat-bed Truck Removalwrecker, attach the straps to the LOWEST possible point on the dolly, and lower the gantry at the SLOWEST reasonable rate, (see [Figure 15-1 Proper Gantry Strap Location on page 160](#))

CAUTION

Tilt-bed truck is no longer an approved delivery methods. It is allowed to use a tilt-bed truck (tilt disabled) as a flatbed truck and use a forklift or crane to unload a system.

Figure 15-1 Proper Gantry Strap Location

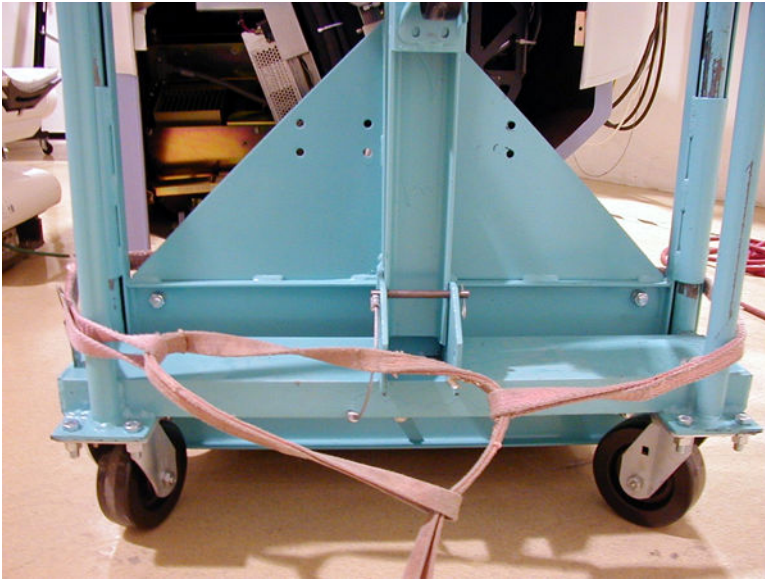
**WARNING**

SOME ASSEMBLIES MAY BE TOP-HEAVY. BE CAREFUL NOT TO TIP!

Appendix A Regulatory Clearances for US

A.1 Regulatory Clearances

There are federal regulations and national standards which determine the minimum clearances for United States (US) installations. These include:

- 29 CFR 1910 (OSHA)
- NFPA 70E (Standard for Electrical Safety in the Workplace)
- NFPA 101 (Life Safety Code)
- Americans with Disabilities Act

NOTICE

All systems installed within the United States and United States territories, and within United States government facilities, regardless of country, must comply with all United States Federal and local regulations. All systems installed outside the United States must comply with either the national, state, or local regulatory clearance requirements for the country in which the installation occurs, or US Federal regulations, whichever is greater.

Clearance Requirements

A map of clearance requirements necessary for proper operation and servicing of the system is provided in section *Service Clearance Requirements*. This is for standard layout in the suggested room size. Refer to the appendix for alternate layouts and room configurations.

NOTICE

The maps and dimensions shown in this manual depict the required clearances for proper equipment operation and service only. The purchaser is responsible for federal, state, and local codes regarding facility egress and related facility requirements. The use of alternate layouts puts severe limitations on space for patient care and work flow. Customer approval of site drawings signifies customer agreement to these limitations.

Figure A-1 Regulatory Clearance Requirements

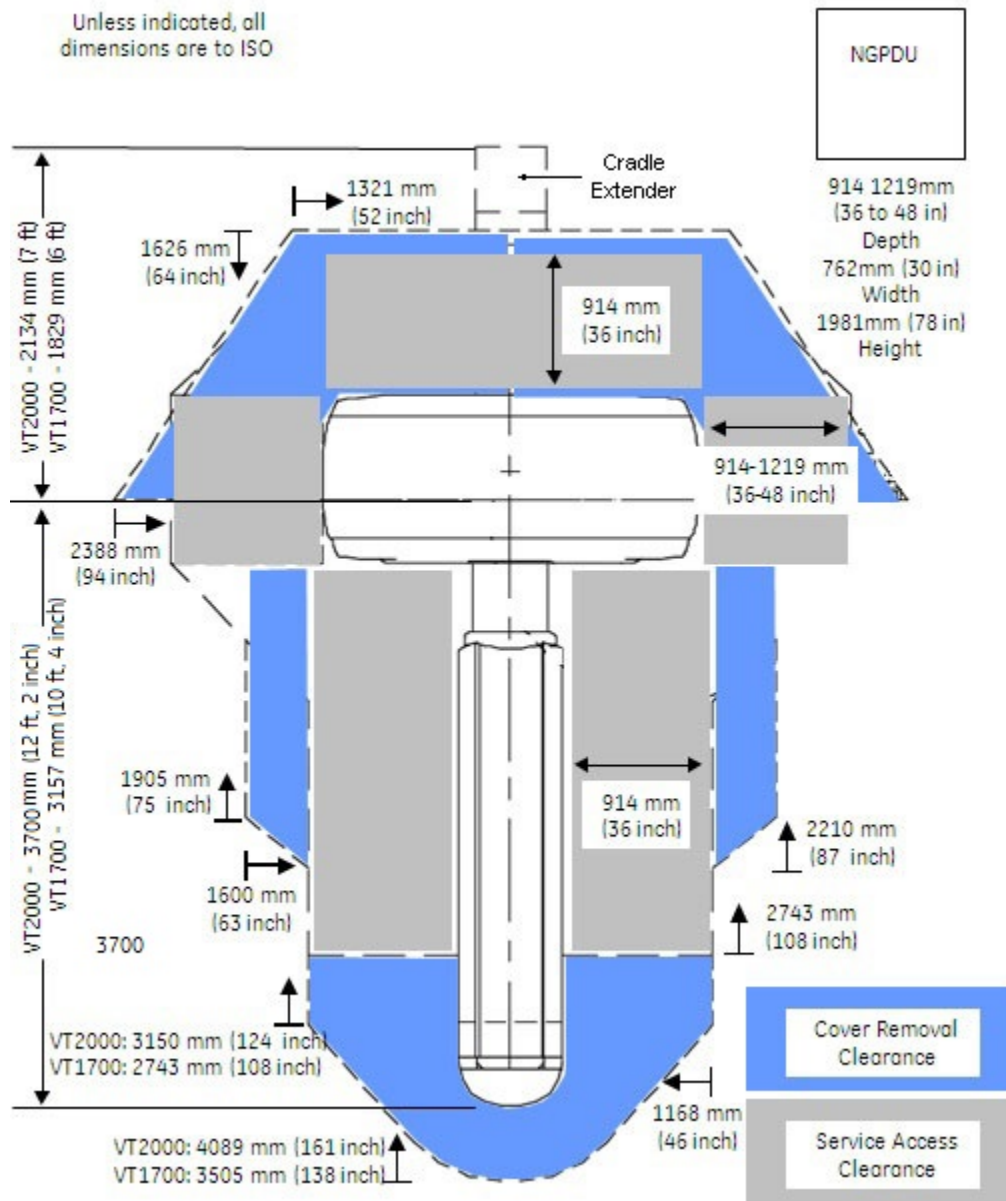

A.2 Minimum Regulatory Workspace Clearances by Major Subsystem

Note the following when referring to the tables below:

- These requirements apply to equipment operating at 600 V or less, where examination, adjustment, servicing, or maintenance is likely to be performed with live parts exposed.
- The customer **MUST** maintain the required regulatory clearance distances and may **NOT** use these area for storage. This applies during normal system operation as well as during service inspection and maintenance.
- Direction of Service Access refers to a direction perpendicular to the surface of the equipment serviced.

Table A-1 CONSOLE – minimum work-space clearances

Work-space Requirement	Minimum Clear Space	Additional Conditions
Direction of Service Access (front and rear of console)	Not applicable. (no exposed live part hazards.)	
Service Access Width (front and back of work-space)		Refers to the width of the working space in front of equipment. 762 mm (30 in) minimum or the equipment width, whichever is greater.
Head Clearance	1981 mm (78 in)	Refers to the height of the work-space measured from the floor at the front edge of the equipment to the ceiling or any overhead obstructions. 1981 mm (78 in) or the height of the equipment, whichever is greater.
Note: Distances are measured to the finished covers.		

Table A-2 NGPDU – minimum work-space clearances

Work-space Requirement	Minimum Clear Space	Additional Conditions
Direction of Service Access (front of PDU)	914 mm (36 in)	1219 mm (48 in) if exposed live parts of 151-600 V are present on both sides of the work-space with the operator between. 1067 mm (42 in) if the opposite wall is grounded and exposed live parts of 151-600 V are present.
Service Access Width (front of work-space)	762 mm (30 in)	Refers to the width of the working space in front of equipment. 762 mm (30 in) minimum or the equipment width, whichever is greater.
Head Clearance	1981 mm (78 in)	Refers to the height of the work-space measured from the floor at the front edge of the equipment to the ceiling or any overhead obstructions. 1981 mm (78 in) or the height of the equipment, whichever is greater.

Table A-3 GANTRY – minimum work-space clearances

Work-space Requirement	Minimum Clear Space	Additional Conditions
Direction of Service Access (all sides)	914 mm (36 in)	1219 mm (48 in), if exposed live parts of 151-600 V are present on both sides of the work-space with the operator between. 1067 mm (42 in), if the opposite wall is grounded and exposed live parts of 151-600 V are present.
Service Access Width (left -right of work-space)	762 mm (30 in)	Refers to the width of the working space in front of equipment. 762 mm (30 in) minimum or the equipment width, whichever is greater.
Head Clearance	1981 mm (78 in)	Refers to the height of the work-space measured from the floor at the front edge of the equipment to the ceiling or any overhead obstructions. 1981 mm (78 in) or the height of the equipment, whichever is greater.
Note: Distances are measured from the finished covers.		

Table A-4 TABLE – minimum work-space clearances

Work-space Requirement	Minimum Clear Space	Additional Conditions
Direction of Service Access (table head)	not applicable	
Direction of Service Access (table sides)	914 mm (36 in)	Can be reduced to 711 mm (28 in) provided the local team obtains written and signed approval from the local AHJ (Authority Having Jurisdiction). GE must have the signed document on file.
Front Cover Removal (table foot)	686 mm (27 in)	457 mm (18 in) minimum for front gantry cover removal. Refer to the appendix for alternate front cover removal options.
Service Access Width (left-right of work-space)	762 mm (30 in)	Refers to the width of working space in front of equipment. 762 mm (30 in) minimum or the equipment width, whichever is greater.
Head Clearance	1981 mm (78 in)	Refers to the height of the work-space measured from the floor at the front edge of the equipment to the ceiling or any overhead obstructions. 1981 mm (78 in) minimum or the equipment height, whichever is greater.

Note: Distances are measured from the finished covers.

A.3 How to Measure

Figure below offers guidance on the proper way to measure to check minimum regulatory clearances.

Figure A-2 Measuring Minimum Regulatory Clearances

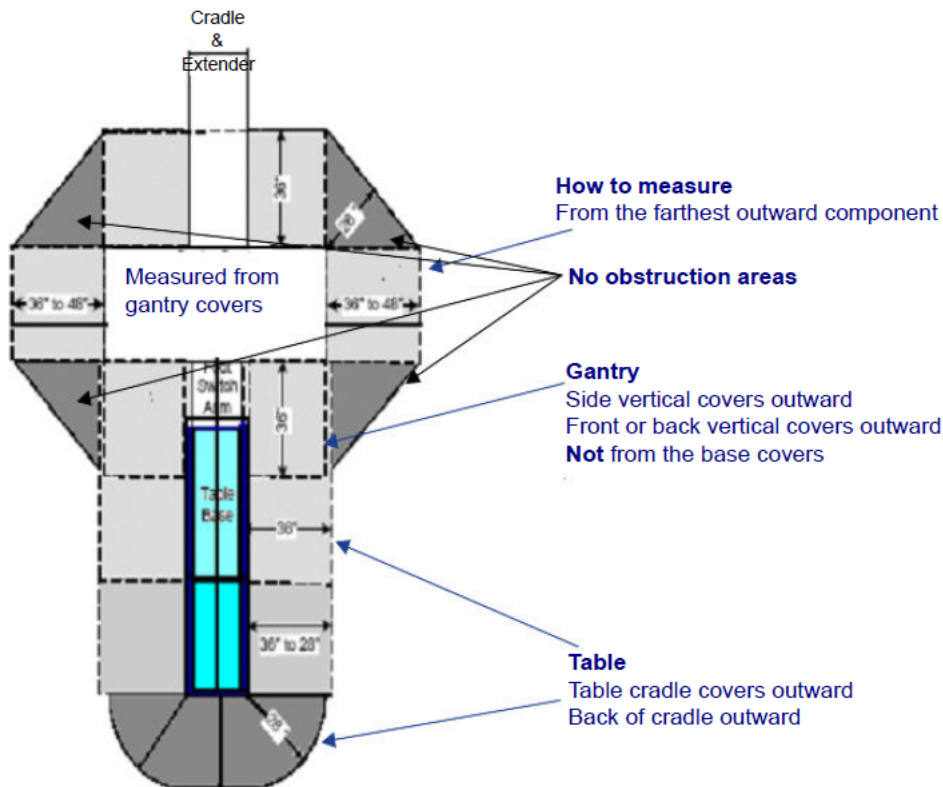

 **CAUTION**

ALL SYSTEM INSTALLATIONS, RELOCATIONS AND MOVES REQUIRE SITE PRINTS.

The CT room layout MUST match the layout shown on your site print and meet all regulatory requirements described in the installation manual. Additional room components, such as cabinets and sinks, reduce room size. Consequently, equipment not shown on the site print may void the caution statement, making the room NONCOMPLIANT.

Actual site measurements obtained by the mechanical installer before installation determines room size and compliance.

 **CAUTION**

IN THE MINIMUM ROOM LAYOUT (356 MM TO 686 MM (14 IN TO 27 IN)

the customer should consider workflow, customer access for patient care and critical care operations space requirements.

Additionally, this layout may offer only limited equipment access on the gantry left side when loading patients or when positioning patient equipment in the room between the gantry and the wall.

NEC Conduit and Duct Fill Rate

Full operation, service, and safety of the system requires the maintenance of sufficient regulatory and service clearances around equipment.

Cable length is an important consideration in room layout. The CT system ships with standard (short) length cables, with a set of longer cables available as an option. Refer to the electrical page of your GE site print for the specific requirements of your site. The following rules govern cable usage for the system:

- When possible, use the rear cable cover assembly to let cables enter the gantry from the rear.
- Do not cut or otherwise shorten long cables.
- Do not store excess cable length behind the operator console, gantry, or PDU.
- Store excess cable in wall or floor ducts, if desired, provided that sufficient space exists. Refer to NEC code to determine cable fill rates for conduits and ducts.
- All installed systems shall comply with NEC 70-E Electrical Regulations governing conduit or duct fill.

Page intentionally left blank

Appendix B Alternate Cover Removal Option

The room dimensions and clearance dimensions shown in this manual assume a room configuration in which the front and rear gantry covers are removed and stored straight back/forward from the gantry. However not all room configurations are the same, meaning covers can be stored in other available spaces. For example, some rooms are long and narrow, while others short and wide. Some rooms may have a support column in the way, or have an adjacent room to store the gantry covers. For this reason, alternative cover removal options for different room configurations are presented.

Front Cover Removal

Rather than storing the front cover straight forward from the gantry at the foot of the table, the cover can be moved and stored on the right or left side of the table if there is space available while still maintaining service access to the table. Additionally, the cover can be moved out of the scan room to a temporary storage location.

The standard procedure for removing the front cover is with the table all the way down. A second method for front cover removal is with the table partially raised and the cradle moved into the bore of the gantry. Under this method, the minimum length of the room can be reduced by 508 mm (20 in).

NOTICE

A room size that utilizes the table-up cover removal method has severe limitations in space for patient care and work flow. The map and dimensions shown in this manual depict the required clearances for proper equipment operation and service only. The customer/purchaser is responsible for federal, state, and local codes regarding facility egress and related facility requirements.

Rear Cover Removal

Rather than storing the rear cover straight back from the gantry, the cover can be moved and stored on the right or left side or angled if there is space available while still maintaining service access to the gantry. Additionally, the cover can be moved to the side of the table or out of the scan room to a temporary storage location.

For rooms with a surface floor duct (without ramps) behind the gantry, the rear cover cannot be moved to the side of the gantry. Due to the weight of the gantry cover, lifting it over a surface floor duct without ramps is prohibited.

Condition References

There are three possible minimum service space requirements based on the construction of the wall directly adjacent to the side of the gantry. The following three conditions determine the minimum space requirement that would apply to the room based on the special conditions of the wall:

- **Condition 1**

If the side of the system being serviced is directly facing an ungrounded surface or wall without live voltage panels and without surface mounted ducts or conduits the minimum space requirement is 914 mm (36 in).

- **Condition 2**

If side of the system being serviced is directly facing a grounded surface or wall the minimum space requirement is 1067 mm (42 in).

• **Condition 3**

If the side of the system being serviced is directly facing a surface or wall with live voltage panels, surface mounted ducts, or conduits the minimum space requirement is 1219 mm (48 in).

Figure B-1 Standard Service Access

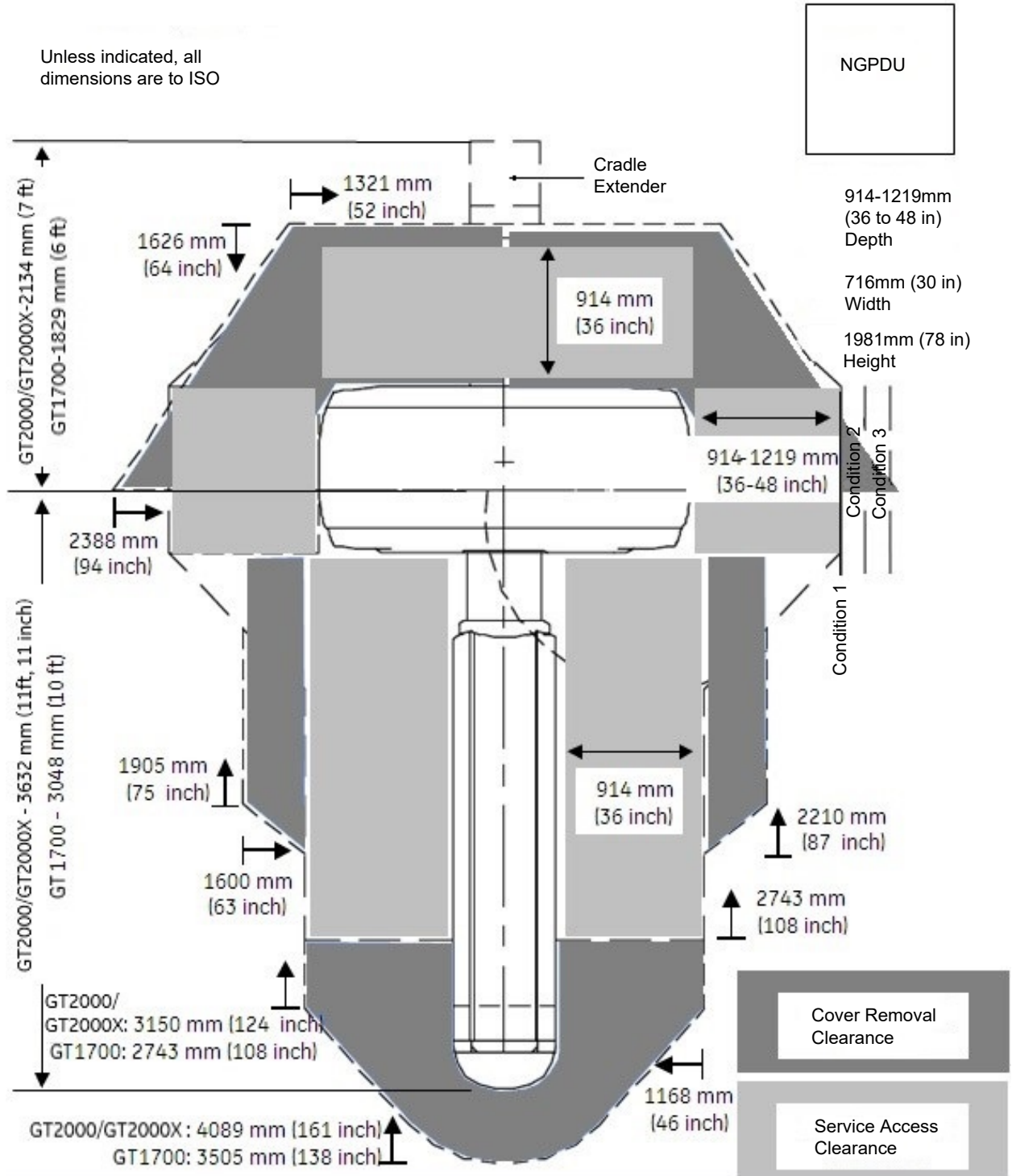

Figure B-2 Front Cover Removal and Storage to Left Side

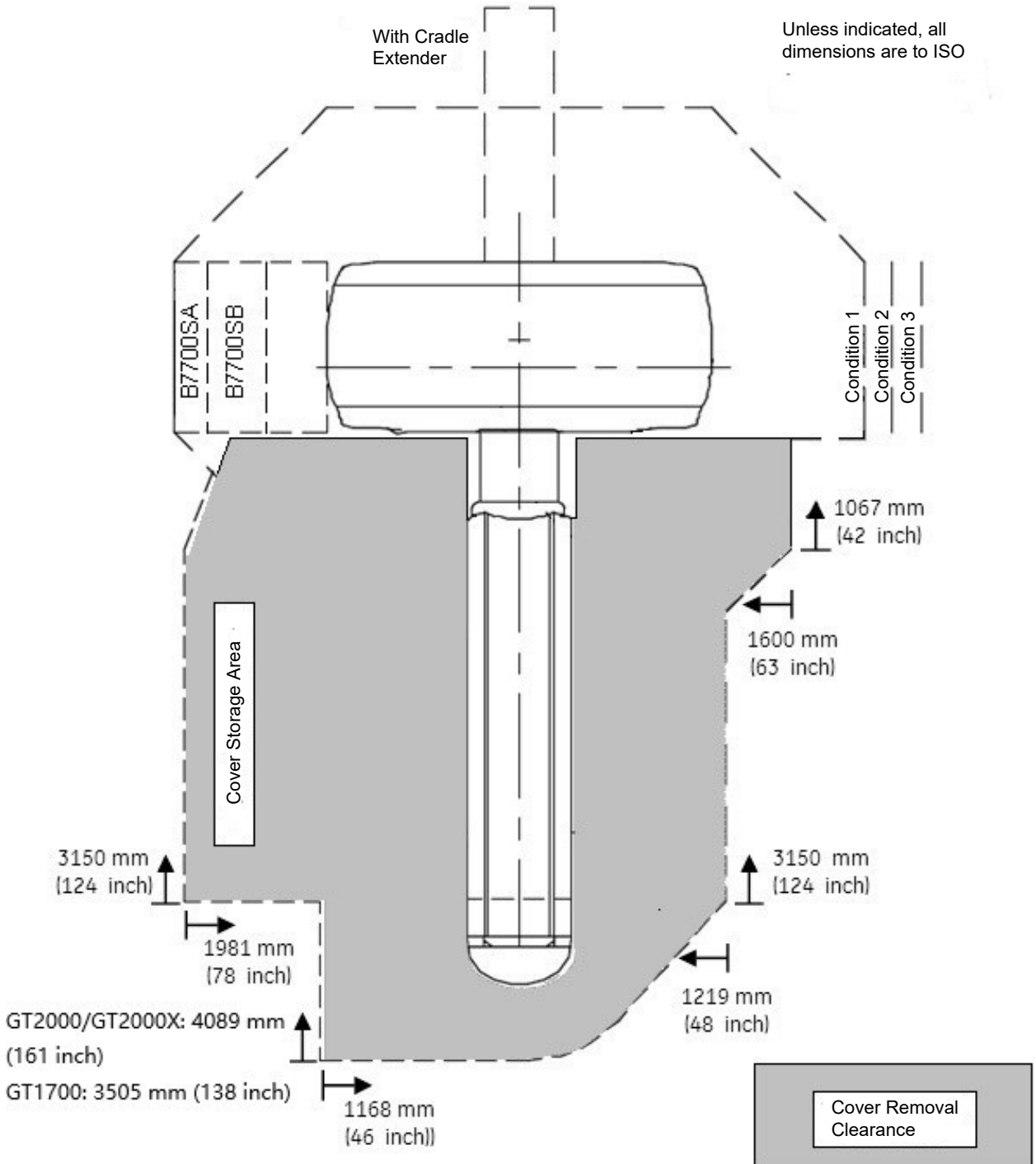

Figure B-3 Front Cover Removal and Storage to Right Side

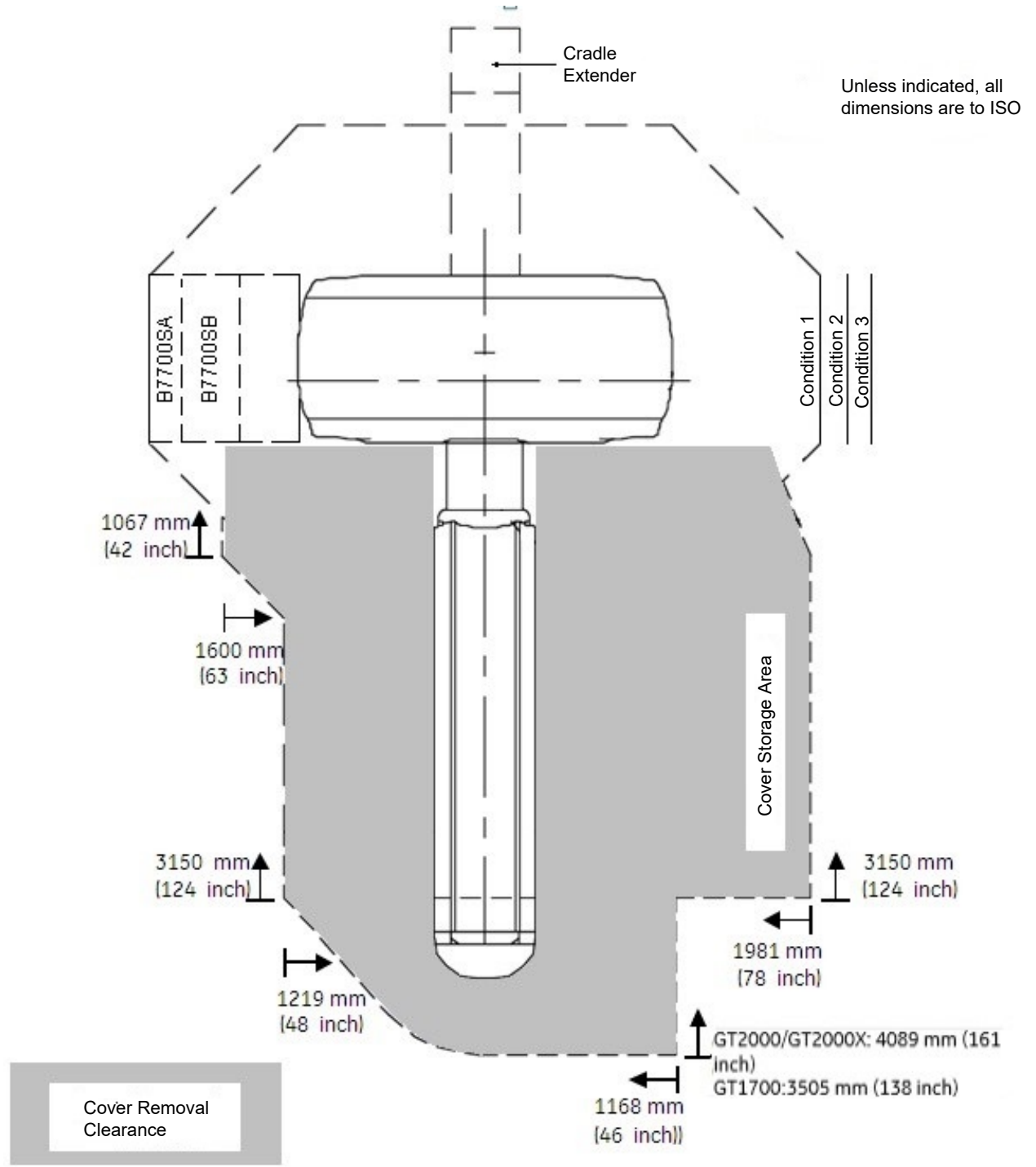

Figure B-4 Front Cover Removal with Table Up, Storage to Left Side

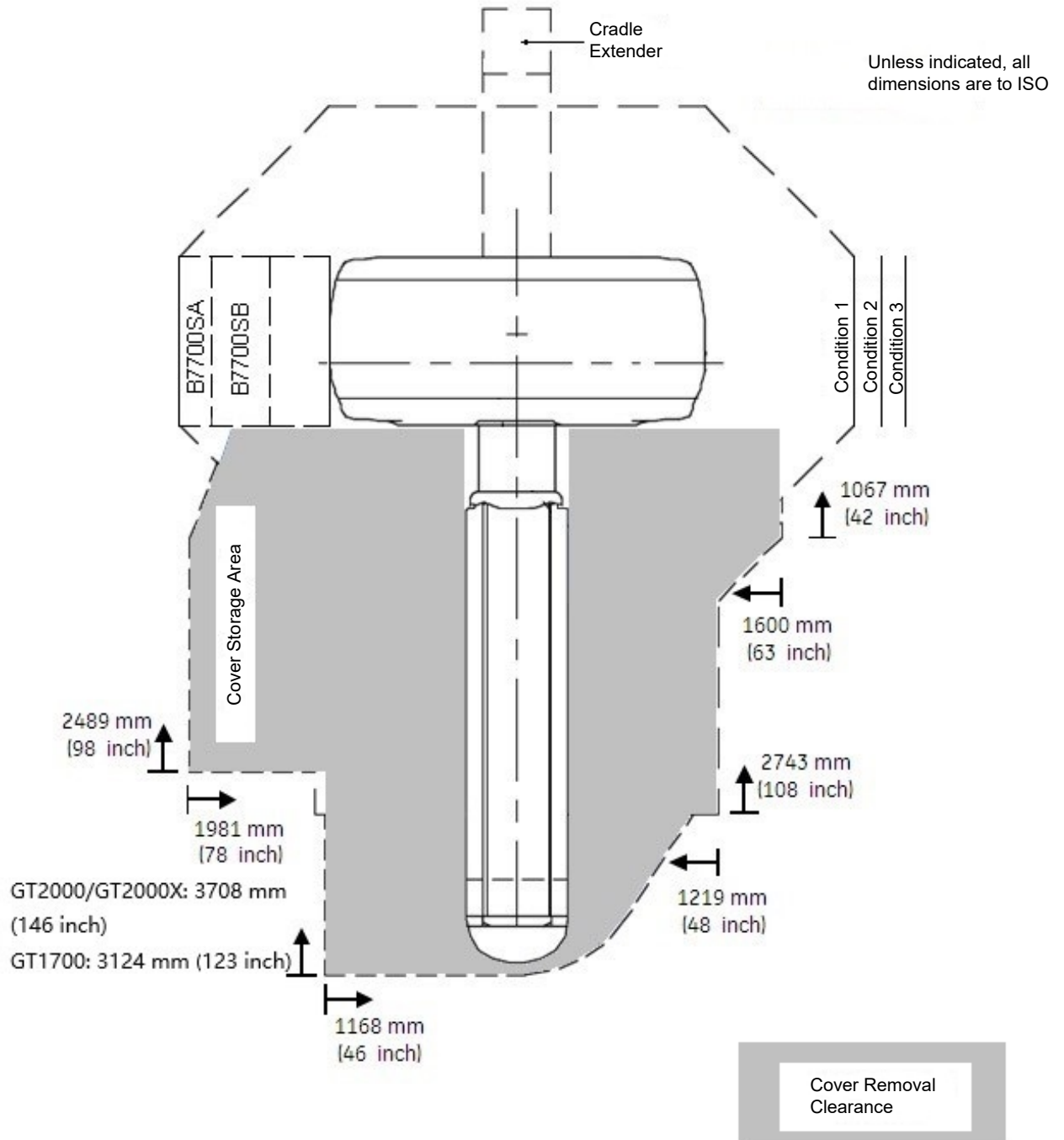

Figure B-5 Front Cover Removal with Table Up, Storage to Right Side

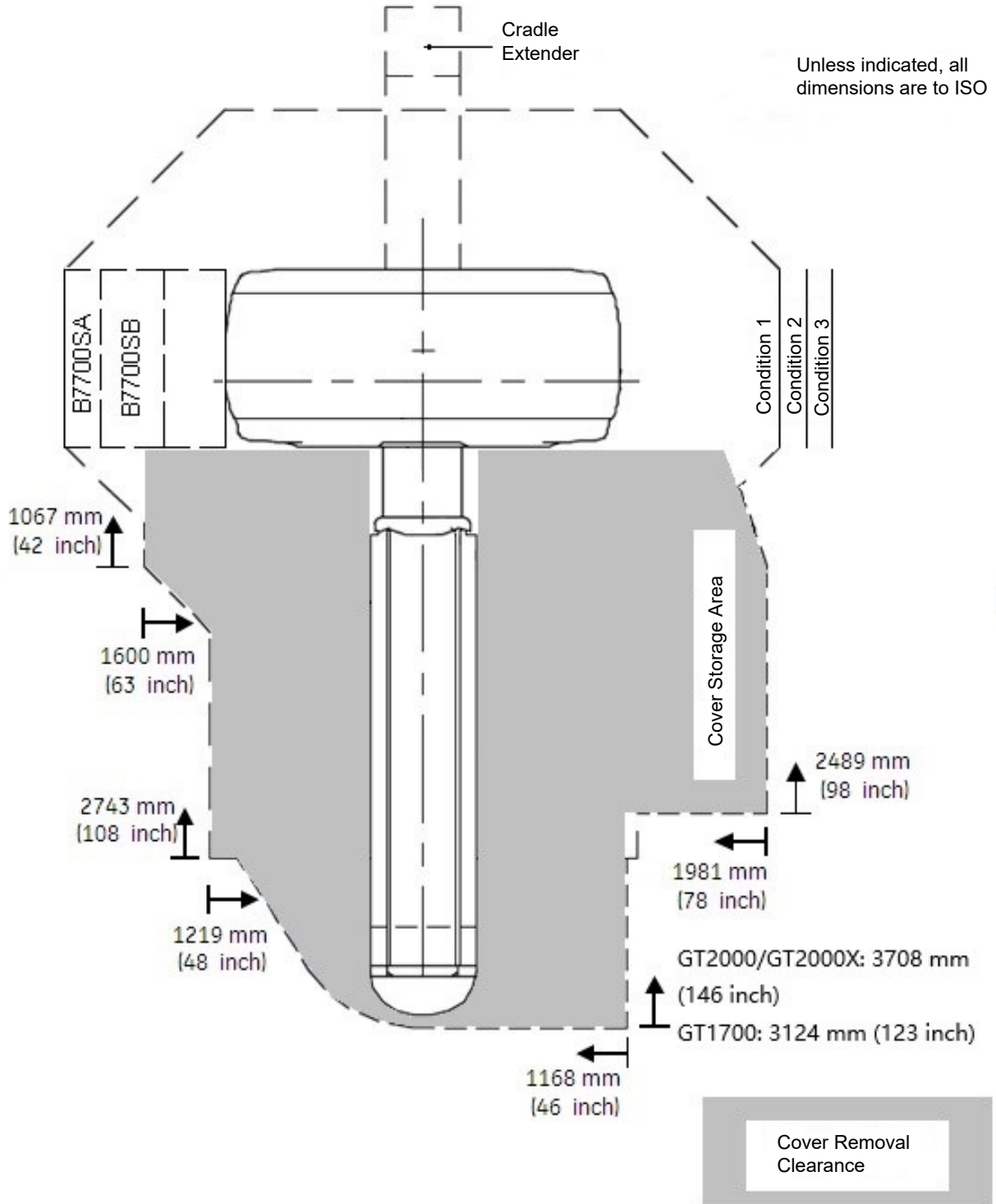

Figure B-6 Rear Cover Removal and Storage Straight Back

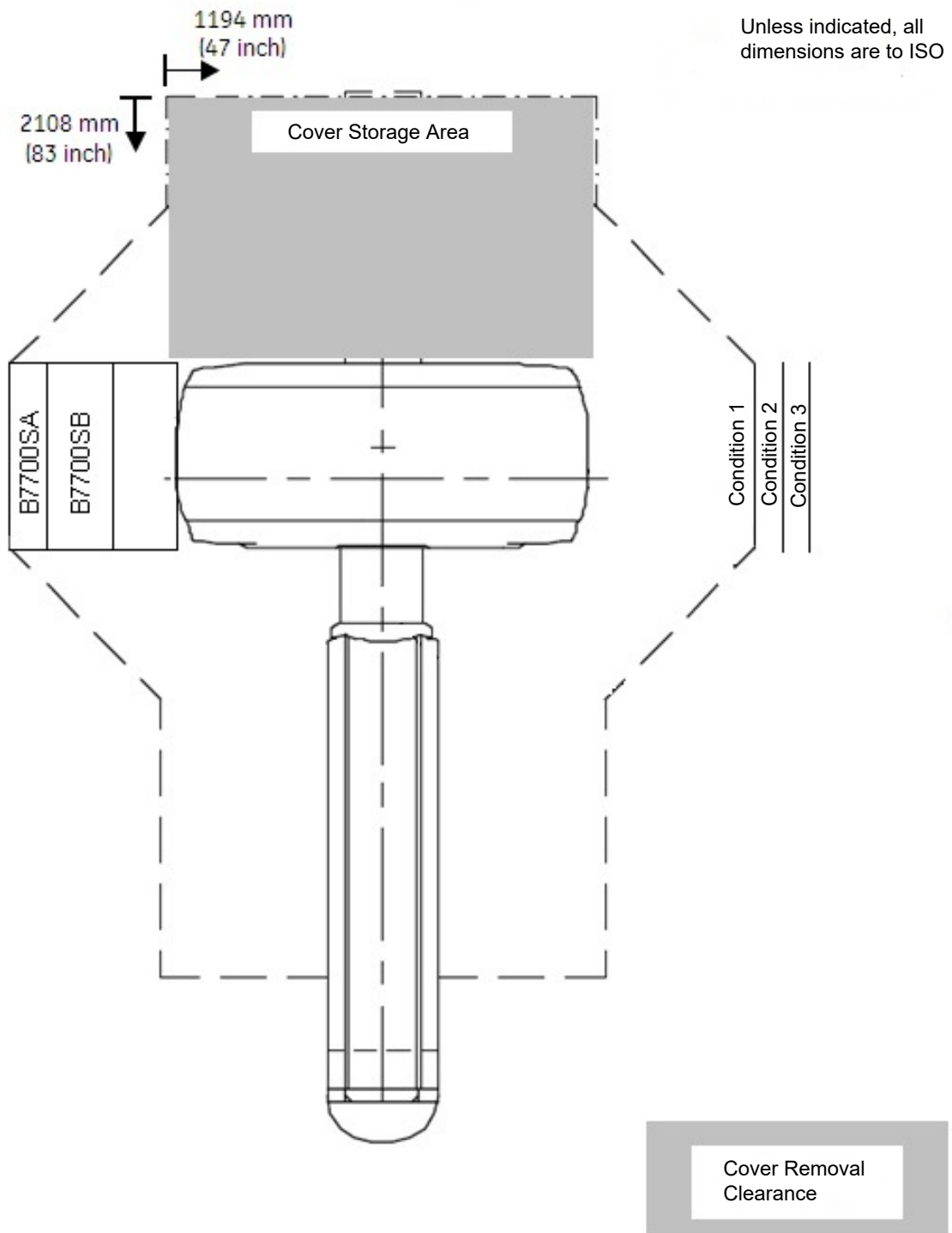

Figure B-7 Rear Cover Removal and Storage to Left or Right Side

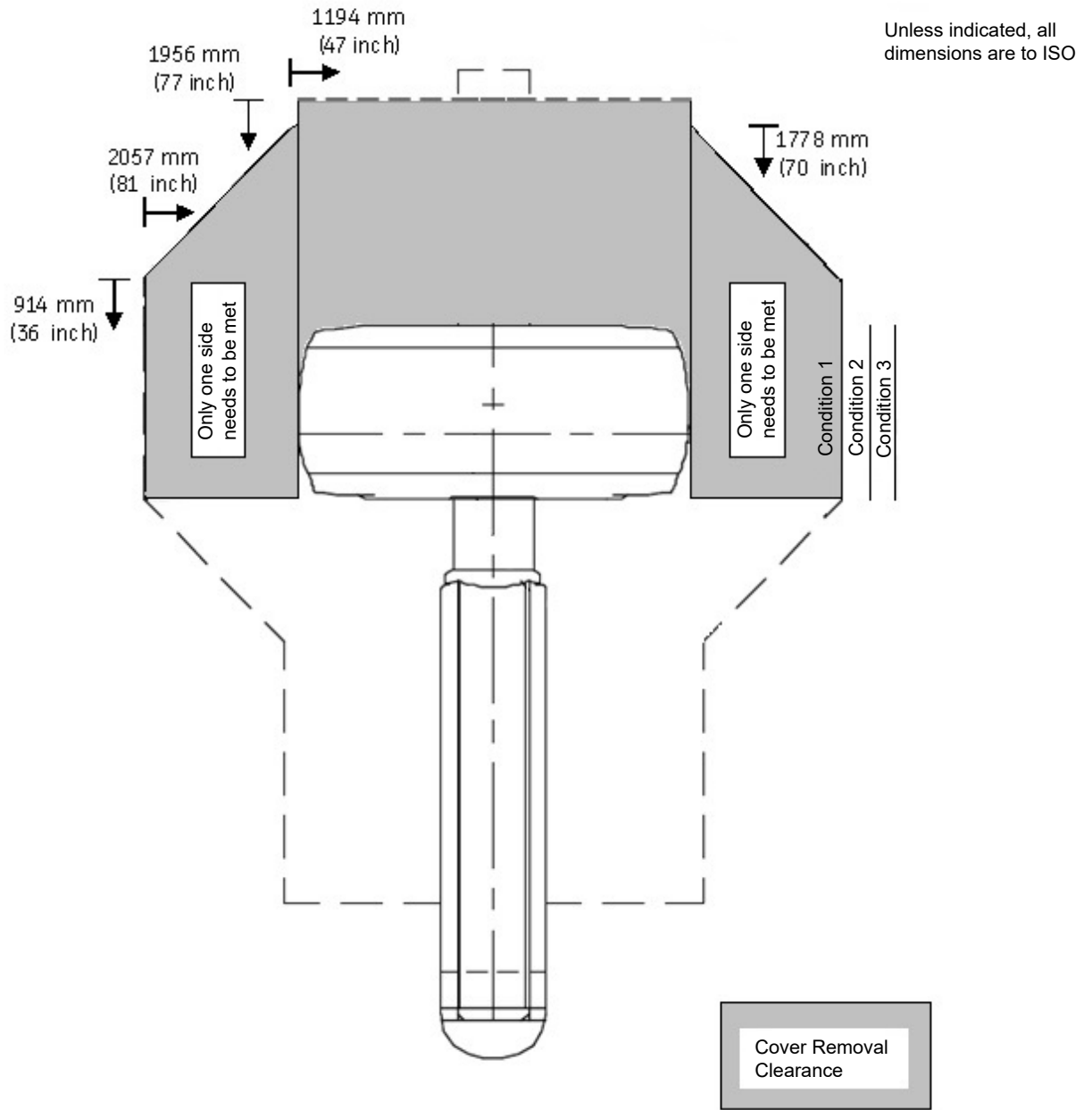
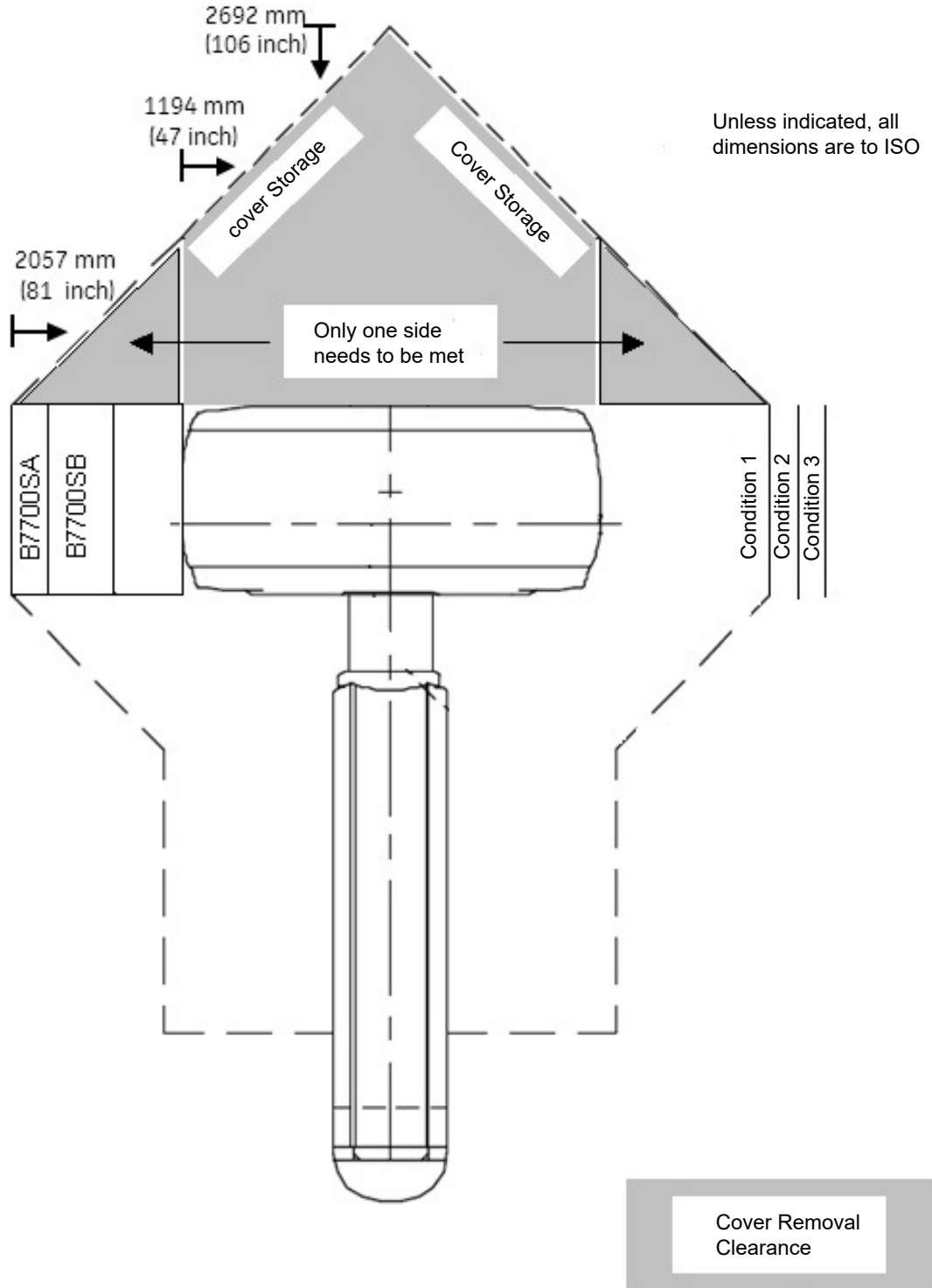

Figure B-8 Rear Cover, Gantry Angled, Storage in Corner



Page intentionally left blank



GE HealthCare

www.gehealthcare.com