



GE HealthCare

**SIGNA™ Creator / SIGNA™ Explorer / SIGNA™
Creator DL / SIGNA™ Explorer DL / SIGNA™
Star / SIGNA™ Aviator**

Preinstallation Manual

5538857-1EN
Revision 15

Contents

1 Introduction	9
1.1 Preinstall Manual Introduction	9
1.1.1 Document Purpose	9
1.1.2 Intended User	9
1.1.3 Who Should Read This Manual	10
1.1.4 Related Publications	12
1.1.5 Document Overview	12
1.2 Symbols Key	13
2 General System Level	14
2.1 System Level Requirements for Installing into Existing MR Suite	14
2.2 System components	15
2.2.1 Magnet Room	15
2.2.2 Equipment Room	15
2.2.3 Control Room	15
2.2.4 Outdoor	16
2.2.5 Accessories	16
2.2.6 System Overview	16
2.3 MR Suite Minimum Room Size Requirements	21
2.4 MR System Seismic Requirements	25
2.5 Structure-borne Vibration Control Specifications	26
2.6 MR Suite Magnetic Field Specifications	28
2.6.1 Magnetic Fringe Field	28
2.6.2 Interference from Changing Magnetic Fields	32
2.6.3 Electrical Current	35
2.6.4 Non-MR System Equipment Sensitivity to Magnetic Fields	36
2.7 Multiple MR System Requirements	37
2.7.1 Multiple Magnets	37
2.7.2 Shared Equipment Rooms	37
2.8 MR Suite Temperature and Humidity	39
2.8.1 Temperature and Humidity Requirements	39
2.8.2 Equipment Heat Output Specifications	41
2.9 Facility Coolant Requirements	43
2.9.1 Type A Configuration	43
2.9.2 Type B Configuration	45
2.9.3 Type B' Configuration	47
2.9.4 Type C Configuration	49
2.9.5 Type D Configuration	52
2.9.6 Type E Configuration	53
2.9.7 Site Provided Facility Chilled Water or Local Chiller Requirements - Type B (B') Configuration	54
2.9.8 Facility Coolant Requirements - Type E Configuration	56

2.9.9 Cryocooler Compressor Temporary Backup Water Requirement - Type B, C, E	57
2.9.10 11 kW Chiller Requirements	58
2.10 MR Suite Electrical Requirements	61
2.10.1 General Electrical Requirements.....	61
2.10.2 GE HealthCare Supplied Main Disconnect Panel (MDP) Specifications for M50022MB and M50022MC.....	64
2.10.3 Customer-supplied Main Disconnect Panel (MDP) Requirements (exempt countries only*).....	70
2.10.4 Emergency Power Backup Specifications (Optional).....	77
2.11 MR System Shipping and Receiving.....	78
2.11.1 Receiving Requirements	78
2.11.2 Facility Delivery Route Requirements	78
2.11.3 MR System Component Shipping Specifications	79
2.11.4 Temperature and Humidity Storage Requirements	82
3 Magnet Room	83
3.1 Magnet Room Introduction.....	83
3.2 Magnet Room Structural Requirements.....	85
3.2.1 Overview.....	85
3.2.2 Environmental Steel Limits	85
3.2.3 Vibration Requirements.....	86
3.3 Magnetic Shielded Room Requirements.....	87
3.4 System Cabinet (SC) and Penetration Panel (PP) Wall Opening Requirements.....	88
3.5 Finished Room Requirements	95
3.5.1 Ferrous Materials in the Magnet Room	95
3.5.2 Walls.....	95
3.5.3 Magnet Preinstallation Markings.....	95
3.5.4 Doors, Magnet Access Openings, and Patient Viewing Windows.....	99
3.5.5 Finished Ceiling.....	99
3.5.6 Magnet Room Floors	99
3.5.7 Storage Cabinets	102
3.6 Magnet Room Equipment Specifications.....	103
3.6.1 Magnet (MAG) Assembly Specifications.....	103
3.6.2 Patient Table (PT) Specifications.....	105
3.6.3 Magnet Rundown Unit (MRU) Specifications and Requirements	107
3.6.4 Blower Box.....	109
3.7 Magnet Room Lighting Requirements.....	110
4 Equipment Room	112
4.1 Equipment Room Overview	112
4.2 Main Disconnect Panel (MDP) Requirements and Specifications	116
4.2.1 Requirements	116
4.2.2 Specifications	116
4.3 System Cabinet (SC)	117
4.4 Mesh Shield and System Cabinet (SC) Cover	120

4.5 Penetration Panel	121
4.6 Cryocooler Compressor (CRY) Specifications	121
4.7 4 kW LCS (LCS4) and 8 kW LCS (LCS8)	125
4.8 MCS	126
4.9 BRM Chiller	127
4.10 11kW Airsys Chiller (Outdoor)	128
4.11 Step Down Transformer (M3335TZ)	131
4.12 Magnet Monitor (MON) Requirements and Specifications	132
4.12.1 Requirements	132
4.12.2 Specifications	132
4.13 Magnetic Resonance Elastography (MRE) Specifications (Optional Equipment)	134
4.13.1 Requirements	134
4.13.2 Specifications	134
5 Control Room	135
5.1 Operator Workspace Equipment Specifications	135
5.1.1 Operator Workspace Assembly	135
5.1.2 Operator Workspace (OW) (Optional Equipment)	136
5.1.3 Global Operator Cabinet (GOC)	137
5.1.4 Host Display	138
5.1.5 Host Keyboard	138
5.1.6 Pneumatic Patient Alert	139
5.2 Oxygen Monitor (OXY) Specifications (Optional Equipment)	140
6 Digital Service and Connectivity Requirements	141
6.1 InSite RSvP (Remote Service Platform) Requirements	141
6.1.1 InSite RSvP Connectivity Requirements	141
7 MR System Interconnects	142
7.1 MR System Interconnects Specifications	142
7.1.1 Component Designator Definitions	142
7.1.2 Available Cable Lengths	143
7.1.3 Magnetic Resonance Elastography (MRE) Option	150
7.2 MR System Interconnects Routing Requirements	151
7.2.1 Cabling Requirements	151
7.3 Facility-Supplied System Interconnects Specifications	153
8 Appendix	156
8.1 Glossary	156
8.2 MR Site Vibration Test Guidelines	158
8.2.1 Test Measurements	158
8.2.2 Equipment (Spectral Analyzer) Set-Up	158
8.2.3 Data Collection	159
8.2.3.1 Ambient Baseline Condition	159

8.2.3.2 Normal Condition	159
8.2.4 Presentation/Interpretation of Results	159
8.3 Sample Calculation AC Power Equipment Minimum Distance	163
8.4 Selecting Anchor Size	165
8.5 Sample control schematic for customer-supplied MDP	166
Revision History.....	168

Language Policy

DOC0371395 - Global Language Procedure

ПРЕДУПРЕЖ ДЕНИЕ (BG)	Това ръководство е налично само на китайски (ZH-CN), английски, френски, немски, японски, корейски, полски, португалски (PT-BR), руски, испански и виетнамски. Ако доставчикът на услуги на даден клиент изисква език, който е различен от тези езици, отговорност на клиента е да предостави преводачески услуги.
警告 (ZH-CN)	本手册仅提供中文 (ZH-CN)、英文、法语、德语、意大利语、日语、韩语、波兰语、葡萄牙语 (PT-BR)、俄语、西班牙语和越南语版本。如果客户的服务提供商需要其他语言，则客户有责任提供翻译服务。
警告 (ZH-HK)	本手冊僅提供中文 (ZH-CN)、英文、法文、德文、意大利文、日文、韓文、波蘭文、葡萄牙文 (PT-BR)、俄文、西班牙文及越南文版本。如客戶的服務供應商需要這些語言以外的版本，則相關客戶有責任提供有關的翻譯服務。
警告 (ZH-TW)	此手冊僅提供中文 (ZH-CN)、英文、法文、德文、義大利文、日文、韓文、波蘭文、葡萄牙文 (PT-BR)、俄文、西班牙文和越南文版本。假如客戶的服務提供者所需語言版本不在所列語言之中，客戶需自行負責提供翻譯服務。
UPOZORENJE (HR)	Ovaj je priručnik dostupan samo na kineskom (ZH-CN), engleskom, francuskom, njemačkom, talijanskom, japanskom, korejskom, poljskom, portugalskom (PT-BR), ruskom, španjolskom i vijetnamskom jeziku. Ako klijentov serviser zahtijeva jezik koji nije jedan od tih jezika, odgovornost je klijenta pružiti uslugu prevođenja.
VÝSTRAHA (CS)	Tato příručka je k dispozici pouze v čínštině (ZH-CN), angličtině, francouzštině, němčině, italštině, japonštině, korejštině, polštině, portugalštině (PT-BR), ruštině, španělštině a vietnamštině. Pokud poskytovatel služeb zákazníka vyžaduje jiný jazyk než tyto jazyky, je odpovědností zákazníka poskytovat překladatelské služby.
ADVARSEL (DA)	Denne vejledning findes kun på kinesisk (ZH-CN), engelsk, fransk, tysk, italiensk, japansk, koreansk, polsk, portugisisk (PT-BR), russisk, spansk og vietnamesisk. Hvis en kundes tjenesteudbyder kræver et andet sprog end disse sprog, er det kundens ansvar at levere oversættelsestjenester.
WAARSCHUWING (NL)	Deze handleiding is alleen beschikbaar in het Chinees (ZH-CN), Engels, Frans, Duits, Italiaans, Japans, Koreaans, Pools, Portugees (PT-BR), Russisch, Spaans en Vietnamees. Als de serviceprovider van een klant een andere taal dan deze talen vereist, is het de verantwoordelijkheid van de klant om vertaalservices te leveren.
WARNING (EN)	This manual is available in Chinese (ZH-CN), English, French, German, Italian, Japanese, Korean, Polish, Portuguese (PT-BR), Russian, Spanish, and Vietnamese only. If a customer's service provider requires a language other than these languages, it is the customer's responsibility to provide translation services.
HOIATUS (ET)	See juhend on saadaval ainult hiina (ZH-CN), inglise, prantsuse, saksa, itaalia, jaapani, korea, poola, portugali (PT-BR), vene, hispaania ja vietnami keeles. Kui kliendi teenusepakkujal on vaja juhendit mõnes muus keeles, on tõlketeenuste osutamine kliendi kohustus.
VAROITUS (FI)	Tämä opas on saatavilla vain kiinaksi (ZH-CN), englanniksi, ranskaksi, saksaksi, italiaksi, japaniksi, koreaksi, puolaksi, portugaliksi (PT-BR), venäjäksi, espanjaksi ja vietnamiksi. Jos asiakkaan palveluntarjoaja edellyttää muuta kuin näitä kieliä, käännöspalveluiden tarjoaminen on asiakkaan vastuulla.
ATTENTION (FR)	Ce manuel est disponible uniquement en allemand, anglais, chinois (ZH-CN), coréen, espagnol, français, italien, japonais, polonais, portugais (PT-BR), russe et vietnamien. Si le prestataire de services d'un client nécessite que le manuel soit rédigé dans une autre langue que celles mentionnées ci-dessus, il incombe au client de le faire traduire.
WARNUNG (DE)	Dieses Handbuch ist nur auf Chinesisch (ZH-CN), Englisch, Französisch, Deutsch, Italienisch, Japanisch, Koreanisch, Polnisch, Portugiesisch (PT-BR), Russisch, Spanisch und Vietnamesisch verfügbar. Wenn ein Dienstleister des Kunden dieses in einer anderen Sprache als die genannten benötigt, liegt es in der Verantwortung des Kunden, Übersetzungsdienstleistungen zu erbringen.

ΠΡΟΕΙΔΟΠΟΙΗΣΗ (EL)	Αυτό το εγχειρίδιο είναι διαθέσιμο μόνο σε Κινεζικά (ZH-CN), Αγγλικά, Γαλλικά, Γερμανικά, Ιταλικά, Ιαπωνικά, Κορεατικά, Πολωνικά, Πορτογαλικά (PT-BR), Ρωσικά, Ισπανικά και Βιετναμέζικα. Εάν ο πάροχος υπηρεσιών ενός πελάτη απαιτεί γλώσσα που δεν συμπεριλαμβάνεται σε αυτές τις γλώσσες, αποτελεί ευθύνη του πελάτη να παρέχει υπηρεσίες μετάφρασης.
FIGYELMEZTETÉS (HU)	Ez a kézikönyv az alábbi nyelveken érhető el: angol, francia, japán, kínai (ZH-CN), koreai, lengyel, német, olasz, orosz, portugál (PT-BR), spanyol és vietnámi. Ha az ügyfél szolgáltatója ezektől eltérő nyelvű kézikönyvet szeretne, akkor az ügyfél feladata, hogy gondoskodik a megfelelő fordításról.
AÐVÖRUN (IS)	Þessi handbók er aðeins fánleg á kínversku (ZH-CN), ensku, frönsku, þýsku, ítölsku, japönsku, kóresku, pólsku, portúgölsku (PT-BR), rússnesku, spænsku og víetnömsku. Ef þjónustuaðili viðskiptavinar þarfnast annars tungumáls en þessara tungumála er það á ábyrgð viðskiptavinarins að veita þýðingarþjónustu.
AVVERTENZA (IT)	Questo manuale è disponibile solo in lingua cinese (ZH-CN), inglese, francese, tedesco, italiano, giapponese, coreano, polacco, portoghese (PT-BR), russo, spagnolo e vietnamita. Qualora un fornitore di servizi del cliente richieda una lingua diversa dall'inglese, sarà responsabilità del cliente fornire il servizio di traduzione corrispondente.
警告 (JA)	このマニュアルは、中国語 (ZH-CN)、英語、フランス語、ドイツ語、イタリア語、日本語、韓国語、ポーランド語、ポルトガル語 (PT-BR)、ロシア語、スペイン語、およびベトナム語のみで提供されています。お客様のサービスプロバイダがこれらの言語以外の言語を必要とする場合は、お客様の責任において翻訳サービスを提供してください。
경고 (KO)	이 설명서는 중국어(중국어-중국), 영어, 프랑스어, 독일어, 이탈리아어, 일본어, 한국어, 폴란드어, 포르투갈어(포르투갈어-브라질), 러시아어, 스페인어, 베트남어로만 제공됩니다. 고객의 서비스 제공자가 이 언어를 제외한 다른 언어를 요구하는 경우, 번역 서비스를 제공하는 것은 고객의 책임입니다.
BRĪDINĀJUMS (LV)	Šī rokasgrāmata ir pieejama tikai ķīniešu (ZH-CN), angļu, franču, vācu, itāliešu, japāņu, korejiešu, poļu, portugāļu (PT-BR), krievu, spāņu un vjetnamiešu valodā. Ja klientu apkalpošanas speciālistam ir nepieciešama cita valoda, kas atšķiras no šeit norādītajām, klienta pienākums ir nodrošināt tulkotājas pakalpojumu.
ĮSPĖJIMAS (LT)	Šis vadovas pateikiamas tik kinų (ZH-CN), anglų, prancūzų, vokiečių, italų, japonų, korėjiečių, lenkų, portugalų (PT-BR), rusų, ispanų ir vietnamiečių kalbomis. Jei klientų paslaugų teikėjui reikalinga kita nei šios kalba, už vertimo paslaugų suteikimą atsako klientas.
ADVARSEL (NO)	Denne håndboken er bare tilgjengelig på kinesisk (ZH-CN), engelsk, fransk, tysk, italiensk, japansk, koreansk, polsk, portugisisk (PT-BR), russisk, spansk og vietnamesisk. Hvis en kundes tjenesteleverandør krever et annet språk, er det kundens ansvar å levere en oversettelsestjeneste.
OSTRZEŻENIE (PL)	Niniejsza instrukcja jest dostępna wyłącznie w języku chińskim (ZH-CN), angielskim, francuskim, niemieckim, włoskim, japońskim, koreańskim, polskim, portugalskim (PT-BR), rosyjskim, hiszpańskim i wietnamskim. Jeśli usługodawca klienta wymaga języka, który nie został wymieniony powyżej, obowiązkiem klienta jest zapewnienie usług tłumaczeniowych.
ATENÇÃO (PT-BR)	Este manual está disponível somente em chinês (ZH-CN), inglês, francês, alemão, italiano, japonês, coreano, polonês, português (PT-BR), russo, espanhol e vietnamita. Se o prestador de serviços de um cliente necessitar de um idioma diferente dos mencionados, o fornecimento dos serviços de tradução é de responsabilidade do cliente.
ATENÇÃO (PT-PT)	Este manual está disponível apenas em alemão, chinês (ZH-CN), coreano, espanhol, francês, inglês, italiano, japonês, polaco, português (PT-BR), russo e vietnamita. Se o fornecedor de serviços de um cliente necessitar de um idioma diferente dos listados aqui, é da responsabilidade do cliente assegurar os serviços de tradução.
ATENȚIE (RO)	Acest manual este disponibil numai în limbile chineză (ZH-CN), engleză, franceză, germană, italiană, japoneză, coreeană, poloneză, portugheză (PT-BR), rusă, spaniolă și vietnameză. Dacă furnizorul de servicii al unui client solicită o limbă diferită față de aceste limbi, este responsabilitatea clientului să furnizeze servicii de traducere.

ОСТОРОЖНО! (RU)	Настоящее руководство доступно только на китайском (ZH-CN), английском, французском, немецком, итальянском, японском, корейском, польском, португальском (PT-BR), русском, испанском и вьетнамском языках. Если поставщику услуг заказчика требуется руководство на каком-либо другом языке, перевод руководства на необходимый язык осуществляется стороной заказчика.
UPOZORENJE (SR)	Ovaj priručnik dostupan je samo na kineskom (ZH-CN), engleskom, francuskom, nemačkom, italijanskom, japanskom, korejskom, poljskom, portugalskom (PT-BR), ruskom, španskom i vijetnamskom jeziku. Ako korisnik kao pružalac usluge zahteva neki drugi jezik od navedenih, njegova je dužnost da obezbedi prevod.
UPOZORNENIE (SK)	Táto príručka je dostupná len v nasledovných jazykoch: čínština (ZH-CN), angličtina, francúzština, nemčina, taliančina, japončina, kórejščina, poľština, portugalcina (PT-BR), ruština, španielčina a vietnamčina. Ak poskytovateľ služieb daného zákazníka požaduje iný ako tieto jazyky, za poskytnutie prekladateľských služieb zodpovedá zákazník.
ATENCIÓN (ES)	Este manual está disponible solo en chino (ZH-CN), inglés, francés, alemán, italiano, japonés, coreano, polaco, portugués (PT-BR), ruso, español y vietnamita. Si el proveedor de servicios de un cliente requiere un idioma distinto de estos idiomas, es responsabilidad del cliente proporcionar los servicios de traducción.
VARNING (SV)	Den här manualen finns endast tillgänglig på kinesiska (ZH-CN), engelska, franska, tyska, italienska, japanska, koreanska, polska, portugisiska (PT-BR), ryska, spanska och vietnamesiska. Om en kunds tjänsteleverantör behöver ett annat språk än dessa är det kundens ansvar att ordna med översättningstjänster.
OPOZORILO (SL)	Ta priručnik je na voljo v kitajščini (ZH-CN), angleščini, francoščini, nemščini, italijanščini, japonščini, korejščini, poljščini, portugalščini (PT-BR), ruščini, španščini in vietnamščini. Če kupčev ponudnik storitev potrebuje drug jezik, mora za prevod poskrbeti kupec.
DİKKAT (TR)	Bu kılavuz yalnızca Çince (ZH-CN), İngilizce, Fransızca, Almanca, İtalyanca, Japonca, Korece, Lehçe, Portekizce (PT-BR), Rusça, İspanyolca ve Vietnamca dillerinde mevcuttur. Müşteri servis sağlayıcısı bu dillerden başka bir dil talep ederse çeviri hizmeti sağlamak müşterinin sorumluluğundadır.
ЗАСТЕРЕЖЕННЯ (UK)	Цей посібник доступний лише китайською (ZH-CN), англійською, французькою, німецькою, італійською, японською, корейською, польською, португальською (PT-BR), російською, іспанською та в'єтнамською мовами. Якщо постачальник послуг замовника використовує мову, яку не вказано у цьому переліку, послуги з перекладу має забезпечити замовник.

1 Introduction

1.1 Preinstall Manual Introduction



(Applies to all subsections within this section)

1.1.1 Document Purpose

This preinstallation manual provides the necessary information to prepare a site for system installation. Specifically, this manual provides information:

1. To define system requirements and interactions.
2. For the effective arrangement and interconnection of system components.
3. The customer is responsible for:
 - 3.1. Compliance with all local and national codes and regulations
 - 3.2. Siting requirements for customer-specific site procedures (medical, MR, safety, and so on)
 - 3.3. Any special architectural requirements (for example, seismic codes)

The implementation of all requirements and adherence to all specifications in this manual is the responsibility of the customer or its architect and engineers. Refer any questions to the GE HealthCare Project Manager of Installation (PMI).

1.1.2 Intended User

The primary users of this manual are the customer, the customer's architectural planner, and/or the customer's contractors.

1.1.3 Who Should Read This Manual

The following personnel must be aware of the content listed in the following sections:

Table 1-1 Personnel Index















Section	Personnel						
							
	Architect	General Contractor	Customer	Electrician	Plumber	HVAC	RF Vendor
1.1 Preinstall Manual Introduction	X	X	X	X	X	X	X
2.1 System Level Requirements for Installing into Existing MR Suite	X	X					
2.2 System components	X	X					
2.3 MR Suite Minimum Room Size Requirements	X						
2.4 MR System Seismic Requirements	X	X					
2.5 Structure-borne Vibration Control Specifications	X						
2.6 MR Suite Magnetic Field Specifications	X		X				
2.7 Multiple MR System Requirements	X						
2.8 MR Suite Temperature and Humidity	X	X			X	X	
2.9 Facility Coolant Requirements	X	X			X	X	
2.10 MR Suite Electrical Requirements	X			X			
2.11 MR System Shipping and Receiving	X						
3.1 Magnet Room Introduction	X	X					
3.2 Magnet Room Structural Requirements	X						
3.2.1 Overview	X						
3.2.2 Environmental Steel Limits	X						
3.2.3 Vibration Requirements	X	X				X	
3.3 Magnetic Shielded Room Requirements	X						
3.4 System Cabinet (SC) and Penetration Panel (PP) Wall Opening Requirements	X		X				X



Table 1-1 Personnel Index (Table continued)

Section	Personnel						
							
	Architect	General Contractor	Customer	Electrician	Plumber	HVAC	RF Vendor
3.5.1 Ferrous Materials in the Magnet Room	X	X	X				
3.5.2 Walls	X						
3.5.3 Magnet Preinstallation Markings	X						
3.5.4 Doors, Magnet Access Openings, and Patient Viewing Windows	X						
3.5.5 Finished Ceiling	X						
3.5.6 Magnet Room Floors	X	X					
3.5.7 Storage Cabinets	X	X					
3.6 Magnet Room Equipment Specifications	X	X					
3.7 Magnet Room Lighting Requirements	X			X			
4 Equipment Room chapter	X	X					
5 Control Room chapter	X	X					
6 Digital Service and Connectivity chapter	X			X			
7.1 MR System Interconnects Specifications	X	X		X			
7.2 MR System Interconnects Routing Requirements	X	X		X			
7.3 Facility-Supplied System Interconnects Specifications	X	X		X	X	X	
8.1 Glossary	X	X	X	X	X	X	X
8.2 MR Site Vibration Test Guidelines	X						
8.3 Sample Calculation AC Power Equipment Minimum Distance	X						
8.4 Selecting Anchor Size	X	X					
8.5 Sample control schematic for customer-supplied MDP	X			X			

1.1.4 Related Publications

The preinstallation requirements in the following publications are applicable to all systems. This document and all documents referenced herein shall be provided to the Responsible Organization or Operator as a supplement to the product instructions for use and/or technical description.

Table 1-2 Additional Preinstallation Requirements

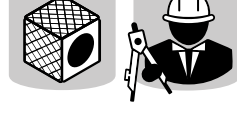
Publication Number	Title	Personnel who must be aware of the content
5850262-1EN	<i>Acoustic Room Details</i>	
5850261-1EN	<i>International Electrotechnical Commission (IEC) Electro-magnetic Compatibility (EMC)</i>	
5850263-1EN	<i>Magnet Room Venting</i>	
5850260-1EN	<i>RF Shielded Room</i>	





1.1.5 Document Overview

This manual describes requirements and specifications for the following:

1. General system requirements that apply to the entire MR suite
2. Shipping and delivery
3. Magnet Room
4. Equipment Room
5. Control Room
6. Interconnects within and between the rooms listed above

1.2 Symbols Key

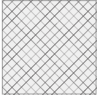
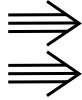
Table 1-3 Symbols Key

Symbol/Unit	Definition
	Center of gravity
	Magnet isocenter
	Service area
	Airflow
	Space for airflow and cables
	Valve

2 General System Level

2.1 System Level Requirements for Installing into Existing MR Suite



When planning for the installation of this system in an existing GE HealthCare MR suite or a non-GE HealthCare MR suite, all requirements in this manual must be met because these rooms are considered new installations.

When upgrading from a Signa OpenSpeed system, extensive building updates are required. The facility must remove any Magnet Room isolation system.

1. If the existing MR suite contains a GE HealthCare system, the vibration environmental assessment must be done using the High Speed (magnetic field) Stability tool.



NOTE

The customer may have to hire a vibration consultant based on the results of the analysis.

2. Structural vibration levels may be higher at some frequencies than other MR Systems, which may increase acoustic levels. Refer to [2.5 Structure-borne Vibration Control Specifications on page 26](#).
3. RF vendor responsibilities:
 - 3.1. The old dock anchor cannot be reused. It must be removed and the hole filled in. The new anchor is reset after the magnet is installed. For upgrades that reuse the existing magnet, contact the PMI for further details about the potential reuse of the old dock anchor.
 - 3.2. Two penetration panel openings are required and must meet the requirements in: *RF Shielded Room Requirements*, 5850260-1EN.
 - 3.3. RF shield attenuation must comply with: *RF Shielded Room Requirements*, 5850260-1EN
4. Cryogen vent may need to be relocated to align with the Magnet Cryogen Vent opening. The cryogen vent must meet all cryogen venting requirements (see *Magnet Room Venting Requirements*, 5850263-1EN).

2.2 System components



(Applies to all subsections within this section)

This system consists of the following components:

2.2.1 Magnet Room

1. 1.5T Magnet and Magnet Enclosure (MAG) and Vibroacoustic Damping Kit
2. Rear Pedestal (PED)
3. Patient Transport Table (PT)
4. Magnet Rundown Unit (MRU)



NOTE

An optional remote MRU may be located outside the Magnet Room.

5. Blower Box (BB)
6. Optional: Remote Oxygen Sensor Module (OM2)

2.2.2 Equipment Room

1. Main Disconnect Panel (MDP) (may be customer-supplied in exempt regions)
2. System Cabinet (SC)
3. Penetration Panel (PP)
4. Cryocooler Compressor Cabinet (CRY)
5. Magnet Monitor (MON)
6. BRM Chiller (BRMC) (For Type D, E)
7. MCS (For Type C, D, E)
8. 4 kW LCS (LCS4) (For Type B)
9. 8 kW LCS (LCS8) (For Type A, B)
10. Optional: Remote Control Panel (RCP) for 11kw Airsys Chiller
11. Optional: Magnetic Resonance Elastography (MRE)

2.2.3 Control Room

1. Operator Workspace equipment (OW)
2. Pneumatic Patient Alert System (PA1)
3. Optional: Oxygen Monitor (OXY)

2.2.4 Outdoor

1. 11 kW Airsys Chiller (WC1 or WC2) (For Type A, C)

2.2.5 Accessories

1. Patient accessories, including RF coils, phantoms, cushions, sponges, straps, and wedges
2. Gating accessories, including patient cardiac leads, peripheral gating probe, and respiratory bellows

2.2.6 System Overview

Figure 2-1 System without equipment room (Type A)

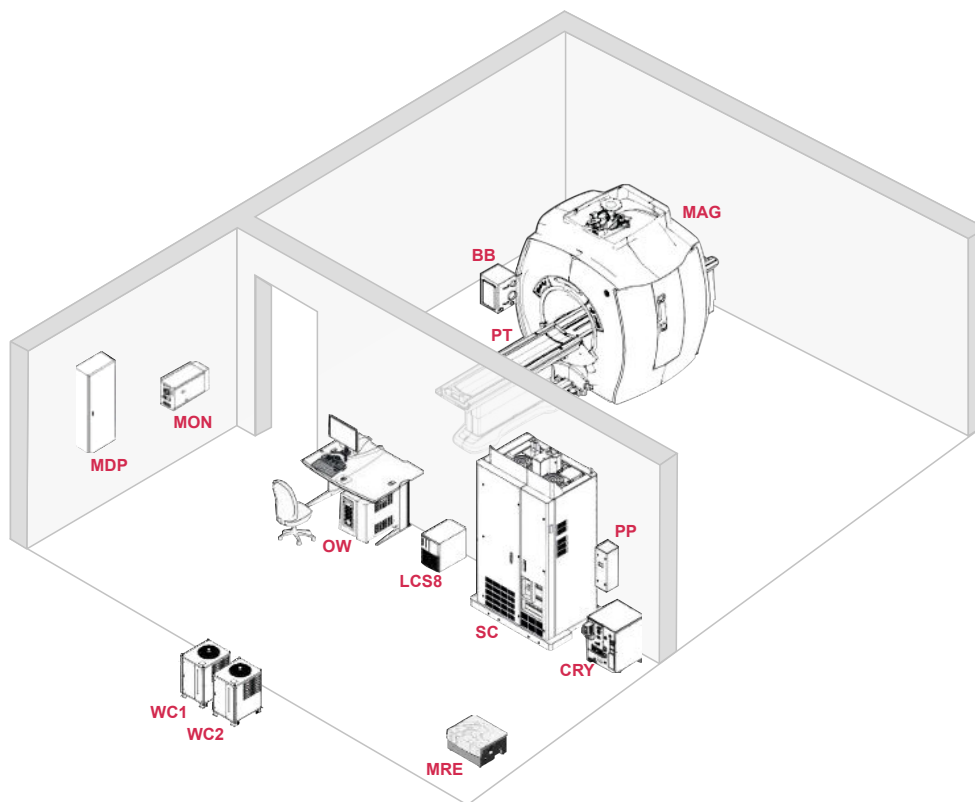

Figure 2-2 System without equipment room (Type B)

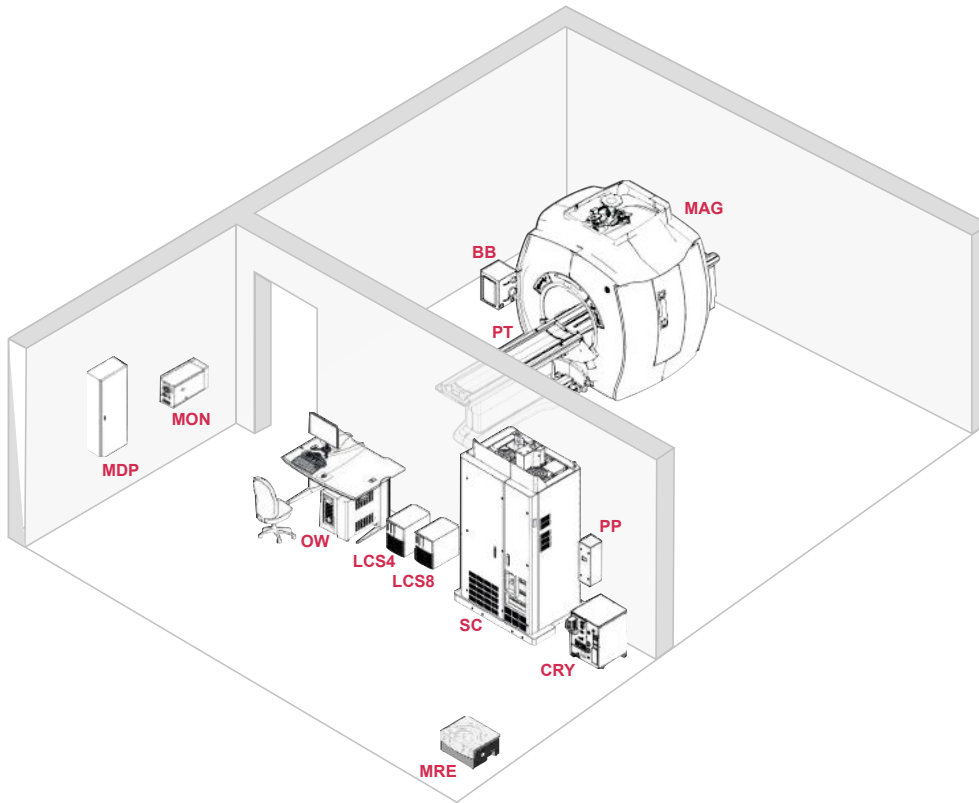
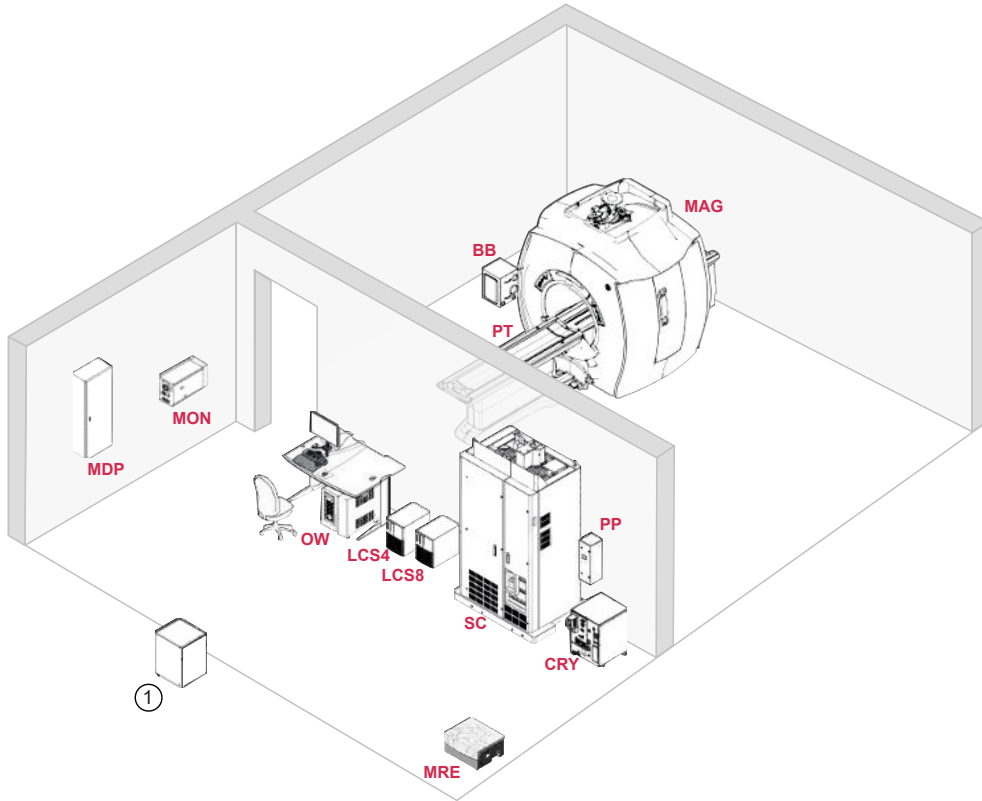

Figure 2-3 System without equipment room (Type B')



Item	Description
1	Locally-Sourced Chiller

Figure 2-4 System with equipment room (Type C)

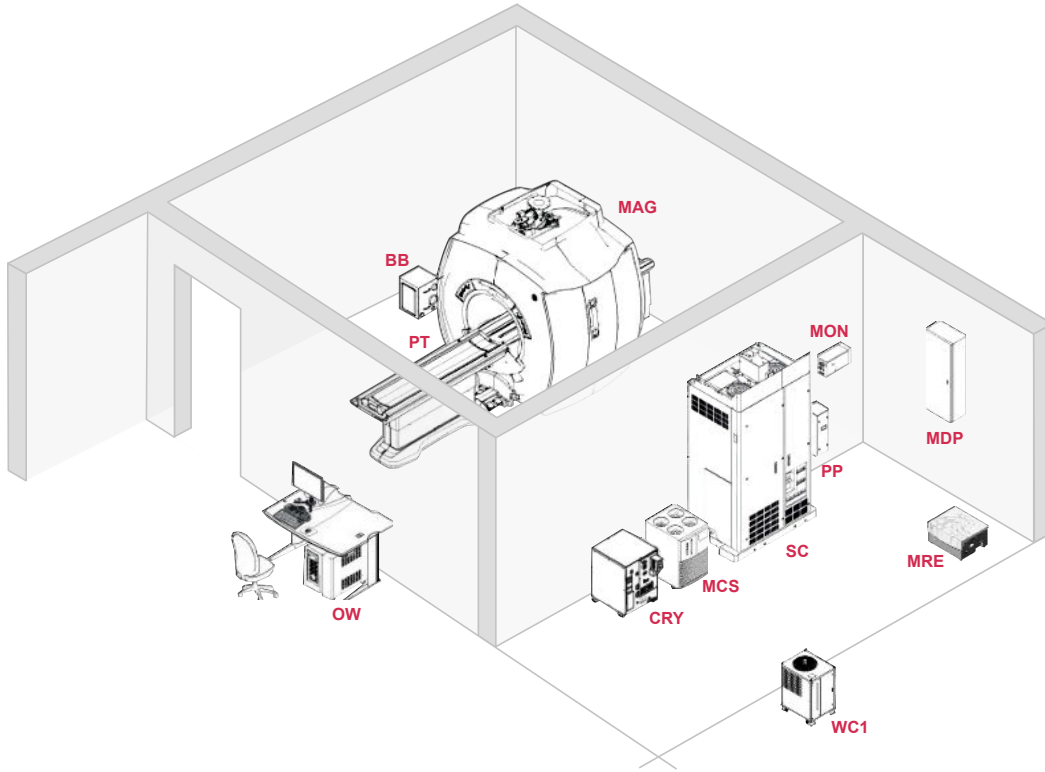

Figure 2-5 System with equipment room (Type D)

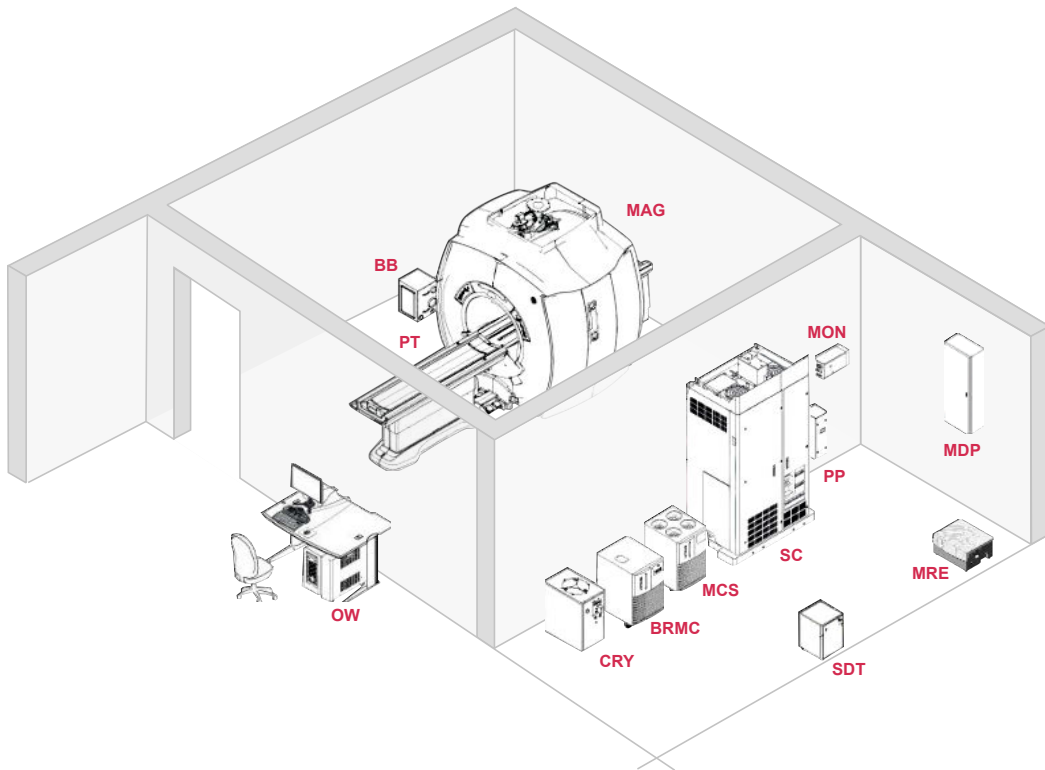
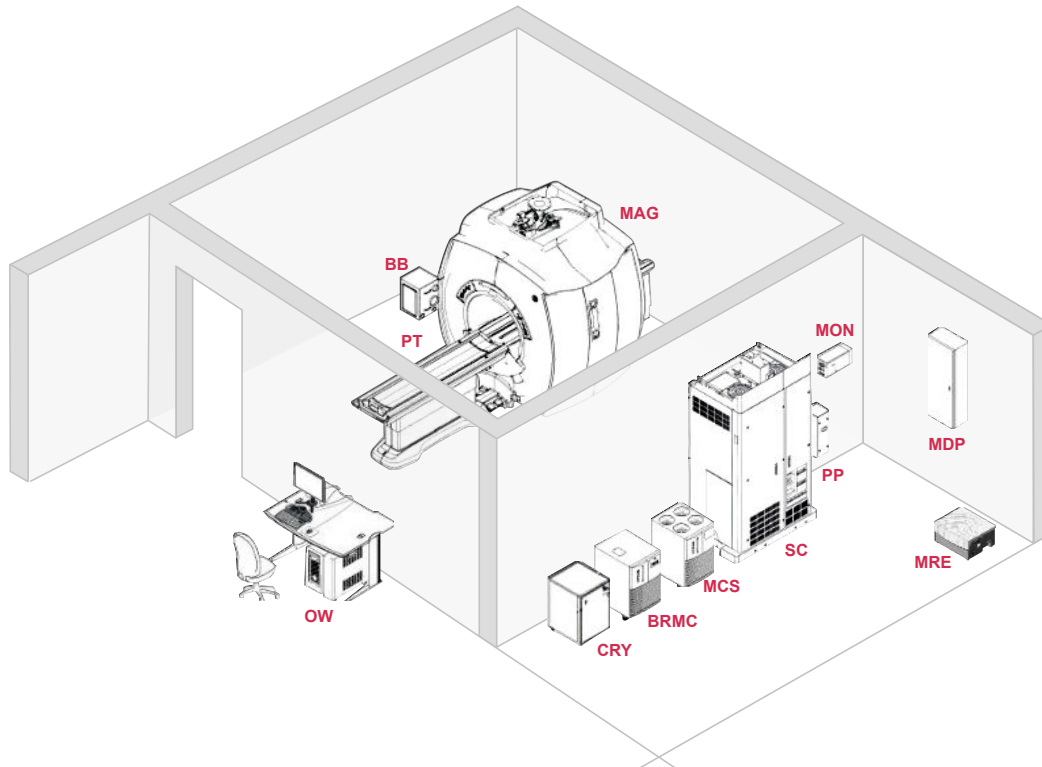

Figure 2-6 System with equipment room (Type E)**NOTE**

MRE and OXY shown above are optional components of the system.

2.3 MR Suite Minimum Room Size Requirements



Room dimensions shown in the table below are the minimum finished room space requirements to safely install and service the MR System. Minimum dimensions are for service only. Room size may increase due to the items listed below, which are not included in the minimum area dimensions:

1. Building code requirements (for example, exit routes, door placement, seismic mounting requirements, local and national electrical codes, and so on).
2. Equipment and Magnet Room evacuation routes to comply with facility emergency procedures.
3. System requirements, including cable run locations, cryogen venting, patient observation requirements, and penetration panel placements.
4. Penetration panel closet and all associated areas.
5. GE HealthCare optional equipment.
6. Non-GE HealthCare equipment options (such as additional AC or water cooling equipment in the Equipment Room).
7. Clinical workflow considerations.
8. Accessory storage. Refer to *Customer Site Storage Requirements*, 5182674 (available in the Customer Documentation Portal), or contact the GE HealthCare Project Manager of Installation (PMI) for any additional accessory storage requirements.
9. Magnetic field containment, for example, the 5 gauss line to the room. If fringe field containment is needed, see [2.6 MR Suite Magnetic Field Specifications on page 28](#).
10. The minimum service area shown must be kept clear of permanent or installed cabinetry, the MRU, the penetration closet, millwork, shelving, coil storage fixtures, furniture, and so on.

Table 2-1 Room Dimensions to Satisfy Recommended Minimum Service Area Requirements

Configuration	Equipment Room		Magnet Room (See the illustrations below for specific dimensions)			Control Room		Total System Area m ² (ft ²)
	W x D mm (in.)	Area m ² (ft ²)	W x D mm (in.)	Area m ² (ft ²)	Finished Ceiling Height mm (in.)	W x D mm (in.)	Area m ² (ft ²)	
System without Equipment Room (Type A, B (B'))	N/A	N/A	3645 x 5802	18.8 (202.2)	2500 (98.4)	3334 x 1900 (131.3 x 74.8)	6.3 (68.5)	25.1 (270.7)
System with Equipment Room (Type C, D, E)	2439 x 2500 ¹ (96 x 98.4)	6.1 (65.7)	(143.5 x 228.4)			1520 x 2130 (59.8 x 83.9)	3.3 (35)	28.2 (302.9)

Table 2-1 Room Dimensions to Satisfy Recommended Minimum Service Area Requirements (Table continued)

Configuration	Equipment Room		Magnet Room (See the illustrations below for specific dimensions)			Control Room		Total System Area m ² (ft ²)
	W x D mm (in.)	Area m ² (ft ²)	W x D mm (in.)	Area m ² (ft ²)	Finished Ceiling Height mm (in.)	W x D mm (in.)	Area m ² (ft ²)	



NOTE

- This Equipment Room dimension is for Type C. Refer to [4.1 Equipment Room Overview on page 112](#) for other Type dimensions.

Table 2-2 Room Dimensions to Satisfy Absolute Minimum Service Area Requirements

Configuration	Equipment Room		Magnet Room (See the illustrations below for specific dimensions)			Control Room		Total System Area m ² (ft ²)
	W x D mm (in.)	Area m ² (ft ²)	W x D mm (in.)	Area m ² (ft ²)	Finished Ceiling Height mm (in.)	W x D mm (in.)	Area m ² (ft ²)	
System without Equipment Room (Type A, B (B ¹))	N/A	N/A	3471 x 5725 (137 x 225)	16.5 (177.6)	2500 (98.4) See Figure 2-9 Area for Minimum Magnet Ceiling Height (Top View) on page 25	3334 x 1900 (131.3 x 74.8)	6.3 (68.5)	22.8 (246.1)
System with Equipment Room (Type C, D, E)	2439 x 2500 ¹ (96 x 98.4)	6.1 (65.7)				1520 x 2130 (59.8 x 83.9)	3.3 (35)	25.9 (278.3)



NOTE

- This Equipment Room dimension is for Type C. Refer to [4.1 Equipment Room Overview on page 112](#) for other Type dimensions.

Figure 2-8 Absolute Minimum Magnet Service Area (Top View)

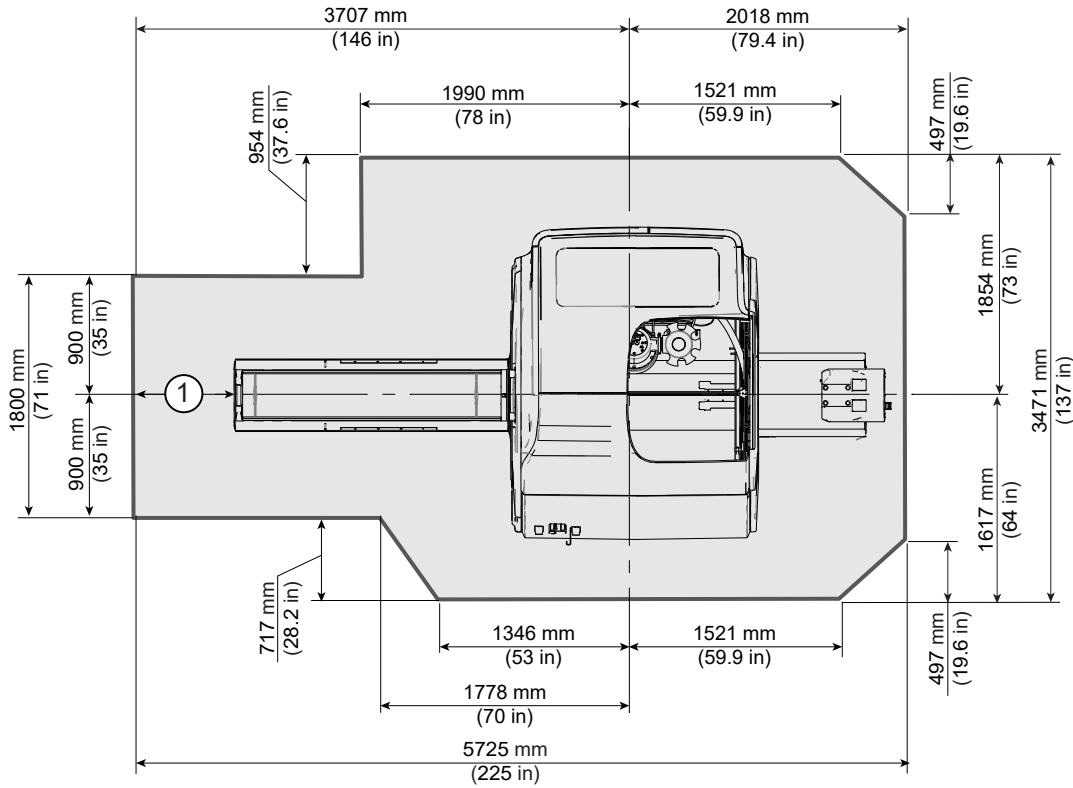

Item	Description
1	603 mm (23.7 in.) is for Low Height Fixed Table 482 mm (19 in.) is for Detachable Table 729 mm (28.7 in.) is for Detachable Lite Table

NOTE The shaded area indicates minimum service area.

The following requirements apply to the Magnet Room finished ceiling:

1. Ideal Magnet Room suspended ceiling height is 2667 mm (105 in.). Minimum Magnet Room suspended ceiling height is 2500 mm (98.5 in.). See [Figure 2-9 Area for Minimum Magnet Ceiling Height \(Top View\) on page 25](#).
2. The ceiling service area should be kept clear of overhead items, including soffits, HVAC, plumbing components, and brackets. Permanent or installed objects in this area may prevent or delay magnet service or operation.

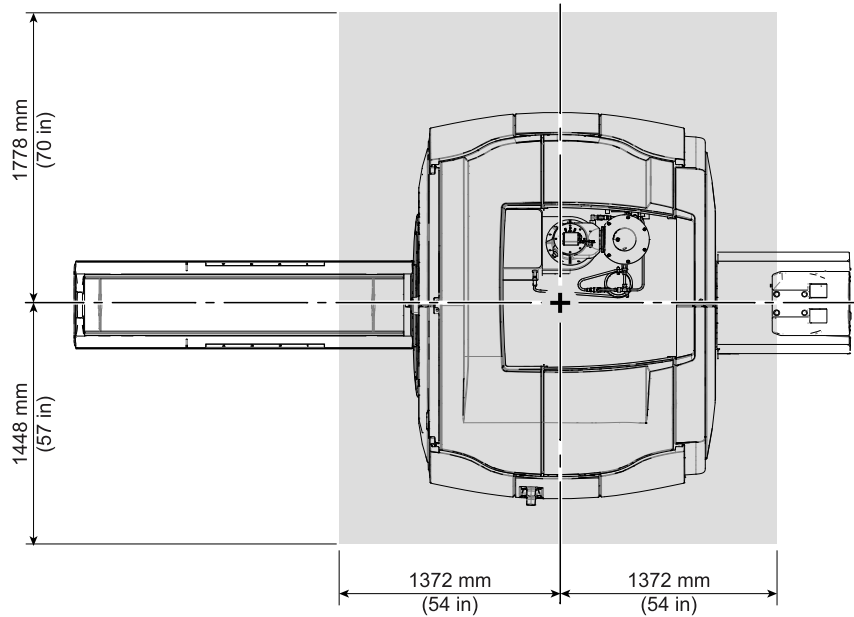
Figure 2-9 Area for Minimum Magnet Ceiling Height (Top View)**NOTE**

If the ceiling height is between **2500 mm (98.5 in)** and **2667 mm (105 in)**, the flexible main lead extension for low ceiling height (2.5M Low Ceiling Kit-Passive, M7000GM) is required for ramping the magnet. Contact the GE PMI and GE Service Field Engineer for further evaluation.

2.4 MR System Seismic Requirements



Contact the Project Manager of Installation with any questions.

1. The customer is responsible for seismic anchoring of GE HealthCare components.
2. Center of gravity, weight, physical dimensions, and attachment points are provided for seismic calculations. Refer to the specifications or illustrations for each component (see [Magnet Room Equipment Specifications on page 103](#), [Equipment Room on page 112](#), and [Control Room on page 135](#)).

2.5 Structure-borne Vibration Control Specifications



Structure-borne acoustic issues tend to occur at MR installations above the ground floor of the facility. Two options to mitigate structure-borne acoustic transmission are:

1. GE HealthCare provides a VibroAcoustic Damping kit (which must be surface mounted). Contact the GE HealthCare Project Manager of Installation for information.
2. The customer may design and implement a custom solution in addition to the VibroAcoustic Damping kit. See [Figure 2-10 Vibration Transmitted through VibroAcoustic Mat on page 26](#) for the plot of spectral vibration transmitted through the VibroAcoustic mat into the floor. If required, the customer should consult an acoustic engineer for a solution to further attenuate this transmitted vibration).



NOTE

The amount of vibration attenuation provided by the VibroAcoustic Damping kit will be site dependent.

Figure 2-10 Vibration Transmitted through VibroAcoustic Mat

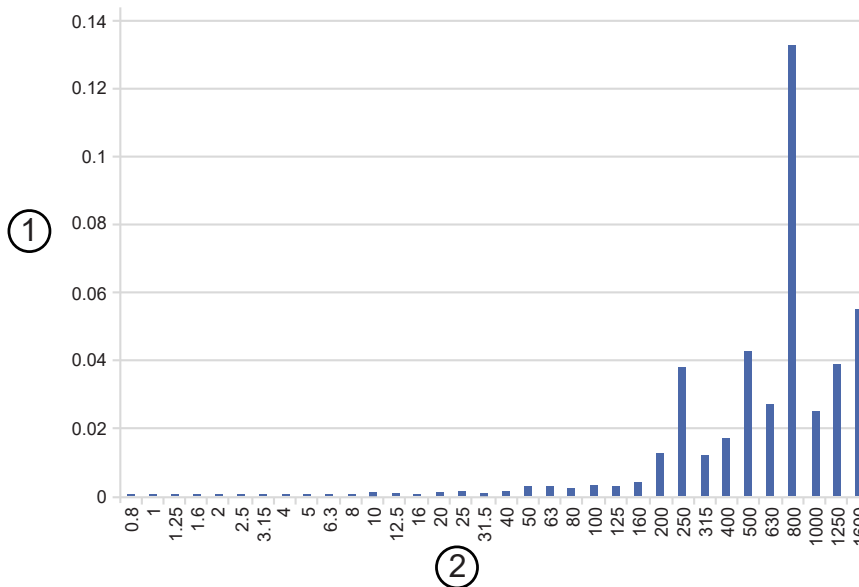

Item	Description
1	Acceleration [m/s ²]
2	1/3 Octave Frequency [Hz]

Figure 2-11 Low Frequency Magnet Floor Vibration (Vibration Amplitude at Each Foot)

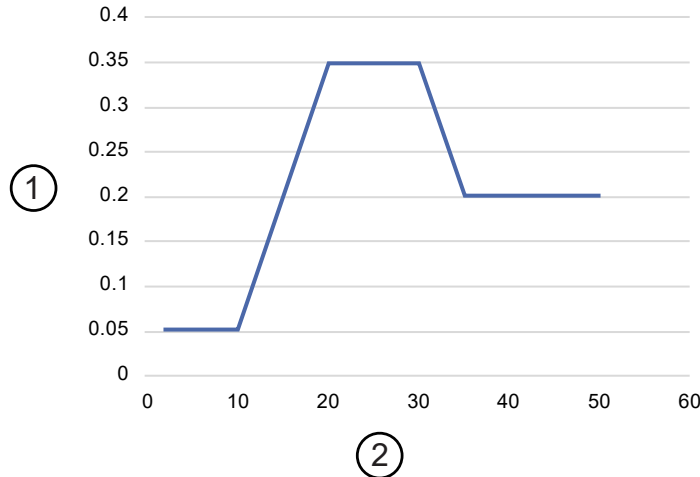

Item	Description
1	Vibration Amplitude (m/s ²)
2	Frequency (Hz)

Frequency (Hz)	Amplitude (m/s ²)
2	0.05
10	0.05
20	0.35
30	0.35
35	0.20
50	0.20

Low Frequency Magnet Floor Vibration Notes:



NOTE

1. Illustrations above define the potential vibration level that may pass into the customer site. [Figure 2-10 Vibration Transmitted through VibroAcoustic Mat on page 26](#) is the high frequency audible vibration. [Figure 2-11 Low Frequency Magnet Floor Vibration \(Vibration Amplitude at Each Foot\) on page 27](#) is low frequency vibration that may dynamically displace the floor.
2. Vibration transfer may be the result of customer specific building construction as low levels of vibration transmit into the building through airborne and structure-borne paths. Customer MR clinicians recognize the vibration defined in the illustrations above is typically short bursts of vibration repeated multiple times as the scan progresses.
3. The customer should consider the impact of this vibration for the evaluation and design solution.

2.6 MR Suite Magnetic Field Specifications

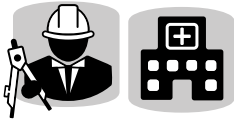

(Applies to all subsections within this section)

2.6.1 Magnetic Fringe Field

The following illustrations show the static magnet isogauss plot lines for the magnet. This information must be used to evaluate potential site interaction of GE HealthCare equipment with other non-GE HealthCare equipment, interaction with ferrous materials on the site, and to locate personnel and equipment within the site.

The 0.5 mT (5G) line can expand to 7.5 m (24.61 ft.) axially and 6.0 m (19.68 ft.) radially for up to 2 seconds in the rare event of a quench.

The isogauss plots show an idealized magnetic field relative to magnet isocenter. The actual field strength can be affected by any of the following:

- Magnetic shielding
- Earth's magnetic field
- Other magnetic fields
- Stationary or moving metal

Figure 2-12 Magnetic Fringe Field Side View

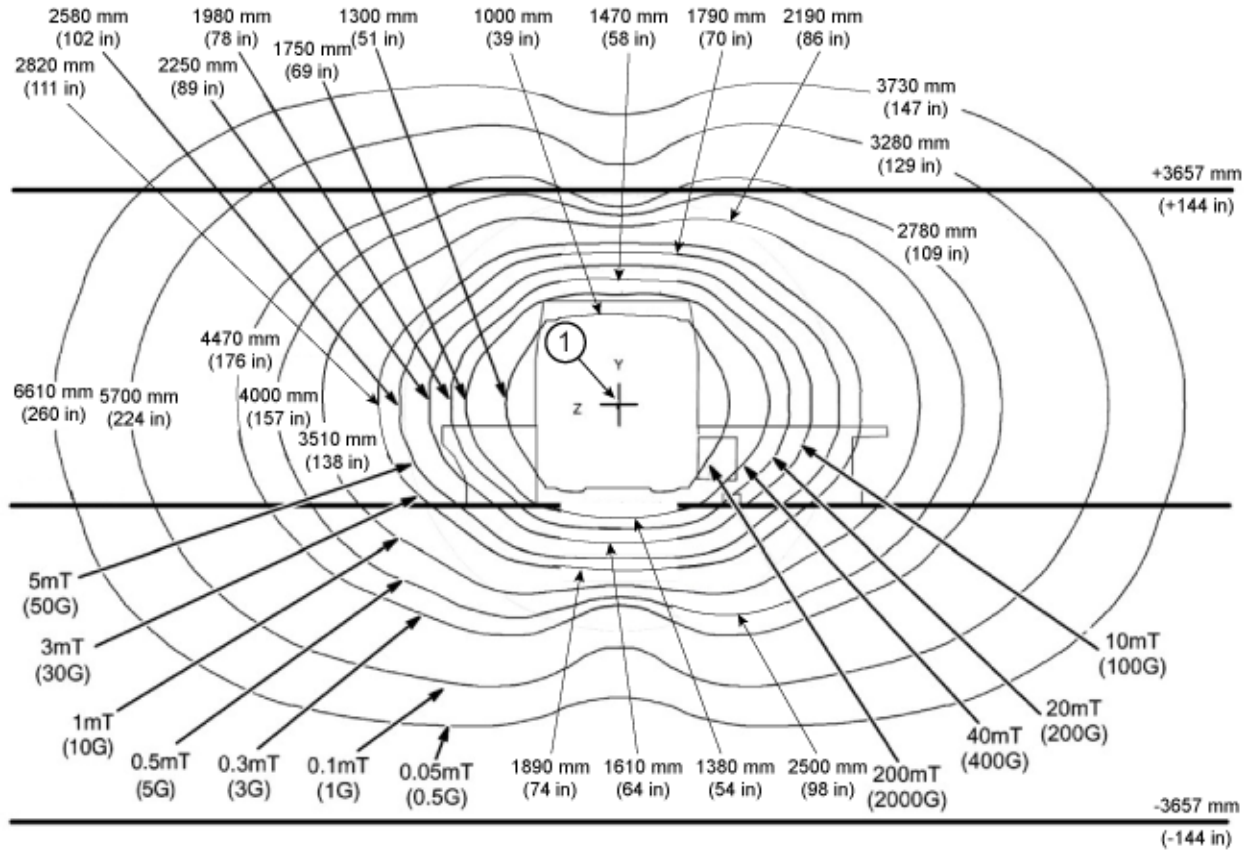

Item	Description
1	Magnet isocenter

Figure 2-13 Magnetic Fringe Field Top View

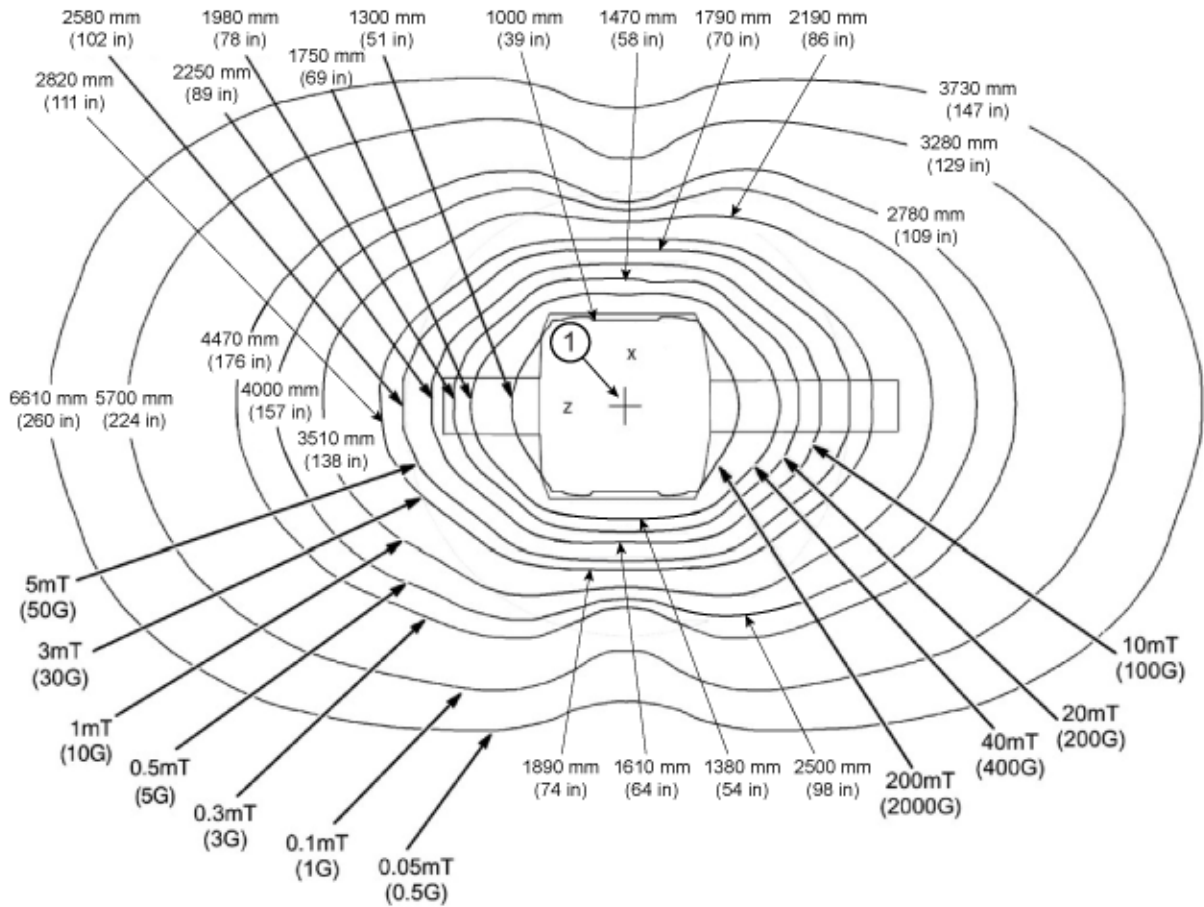

Item	Description
1	Magnet isocenter

Figure 2-14 Magnetic Fringe Field Front View

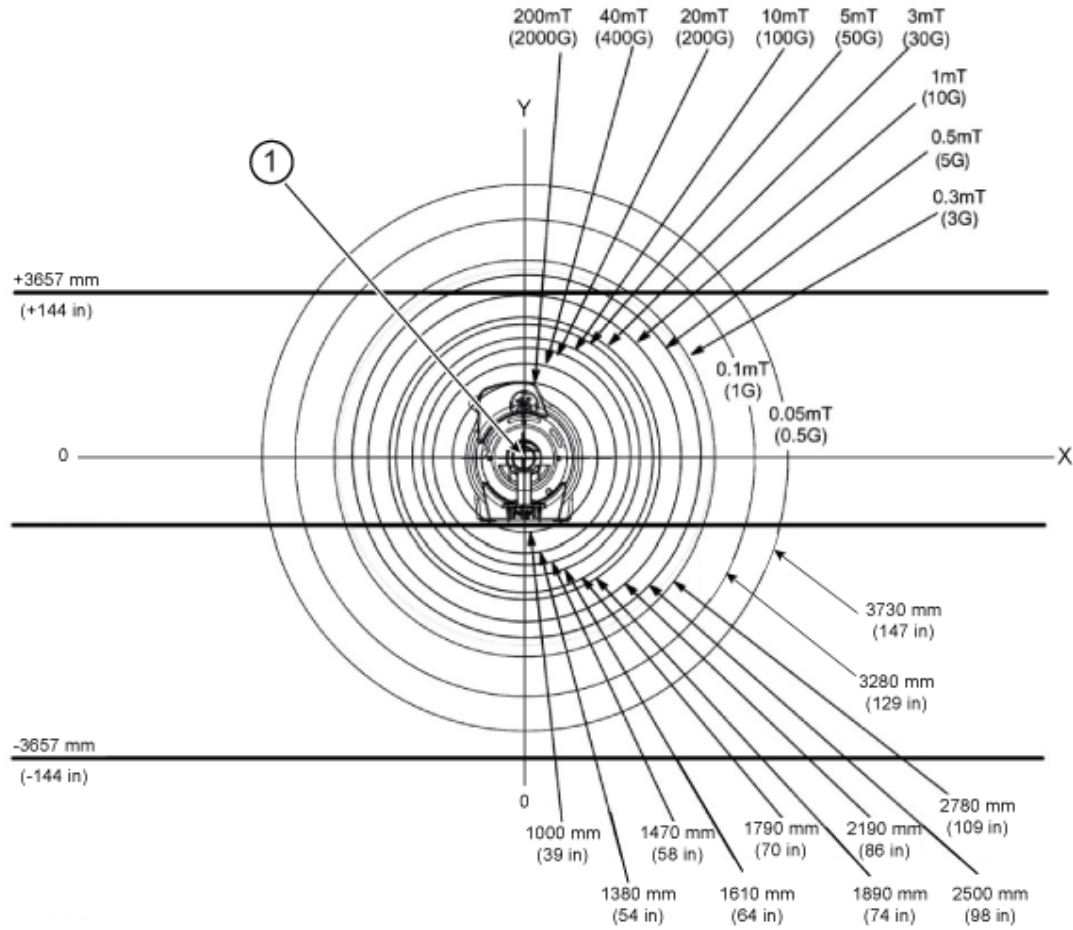

Item	Description
1	Magnet isocenter

2.6.2 Interference from Changing Magnetic Fields

Metal objects moving within the magnet sensitivity lines can produce a field disturbance during clinical imaging. If the metal object is moving it will produce a fluctuating dipole type of field which causes image artifacts. As an example, a car driven inside the moving metal line will act as a dipole and produce a time varying field which changes the magnet's main field during the scanning. The same vehicle may park within the moving metal line and remain parked during clinical scanning without impact to the main field.

Figure 2-15 Magnet Moving Metal Sensitivity Line Plot (Side View)

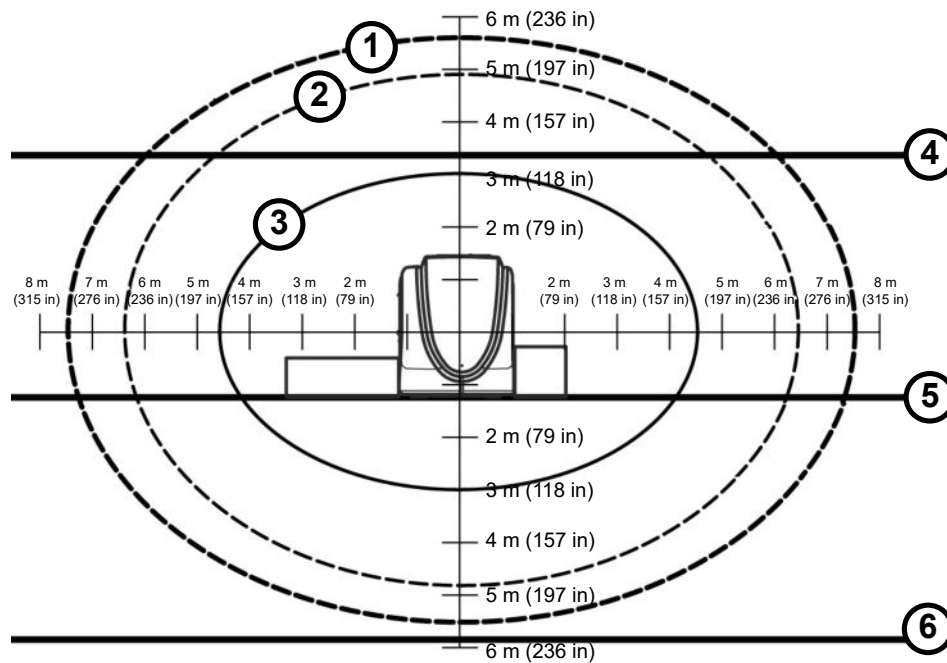

Item	Description	Item	Description
1	Trucks, Buses	4	Floor Above
2	Cars, Pickups, Vans, Ambulances	5	Magnet Room Floor
3	3 Gauss line	6	Floor Below



NOTE

The magnet isocenter, which is 1070 mm (42.1 in.) above the floor, is the origin of both the x-axis and the y-axis.

Figure 2-16 Magnet Moving Metal Sensitivity Line Plot (Top View)

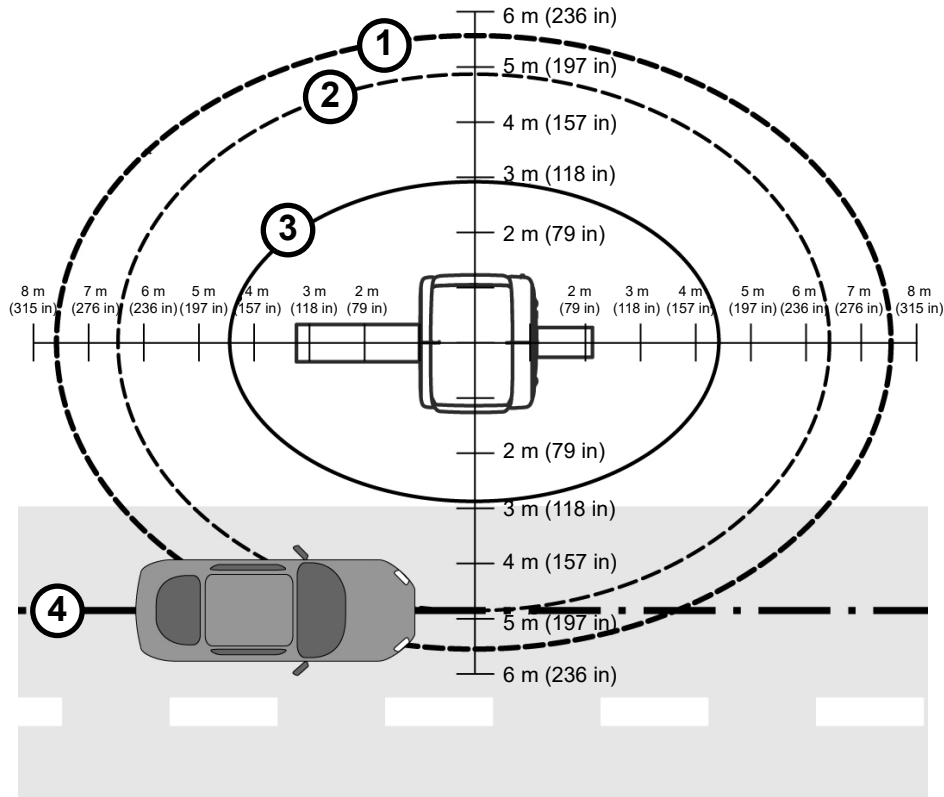

Item	Description	Item	Description
1	Trucks, Buses	3	3 Gauss line
2	Cars, Pickups, Vans, Ambulances	4	Center of Driving Lane

Table 2-3 Magnet Moving Metal Requirements

Metal Objects Category	Definition Of Distance Location	Magnet Minimum Distance Radial X Axial ¹ m (ft.)
Objects 45.36 - 181.44 kg (100 - 400 lb.)	Distance from isocenter radial x axial	0.3 mT (3 G) line
Cars, Minivans, Vans, Pickup Trucks, Ambulances	Distance from isocenter measured to center of driving or parking lane radial x axial	4.72 x 6.40 (15.5 x 21)
Bus, Trucks (Utility, Dump, Semi)	Distance from isocenter measured to center of driving or parking lane radial x axial	5.52 x 7.47 (18.1 x 24.5)
Objects > 181.44 kg (400 lb.), Elevators, Trains, Subways	Place a directional probe (for example, flux gate sensor) at isocenter of proposed magnet location aligned along the Z-axis. Measure peak-to-peak magnetic field change (DC).	See Note 2 below

Table 2-3 Magnet Moving Metal Requirements (Table continued)

Metal Objects Category	Definition Of Distance Location	Magnet Minimum Distance Radial X Axial ¹ m (ft.)
<p>Notes:</p> <ol style="list-style-type: none"> 1. Radial distances are magnet X and Y axis. Axial distances are magnet Z axis. 2. For RD series magnet: EXAMPLE: For moving metal requirements of objects > 181.44 kg (400 lb.) category, you can use the time history of the occurrence to determine what Tesla (Gauss) level to use. <ol style="list-style-type: none"> 2.1. If the site has elevators or counter weights near the magnet, and the elevator can stop on the floors for longer than 20 seconds (which is usually the case), the peak-to-peak reading (Z-axis disturbance) must be less than 443 nanotesla (4.43 milligauss). 2.2. If the site has a subway nearby and the field disturbance is less than 5 seconds, the peak-to-peak reading (Z-axis disturbance) must be less than 443 nanotesla (4.43 milligauss). 2.3. Use 443 nanotesla (4.43 milligauss) peak-to-peak. 		

2.6.3 Electrical Current

1. Electrical current in high voltage power lines, transformers, motors, or generators near the magnet may affect magnetic field homogeneity.
2. Magnetic field interference at 50 or 60 Hz must not exceed 4 μT (40 mG) RMS at the magnet location (see [Figure 2-17 Magnet Allowable Milligauss vs. Line Frequency for AC Equipment on page 35](#)).
3. The following equation can be used as a general guide in determining allowable current in feeder lines at a given distance from the magnet isocenter:
 - 3.1. For 1.5T Magnet: $I = (20X^2)/S$
 - 3.2. I = Maximum allowable RMS single phase current (in amps) or maximum allowable RMS line current (in amps) in three phase feeder lines
 - 3.3. S = Separation (in meters) between single phase conductors or greatest separation between three phase conductors
 - 3.4. X = Minimum distance (in meters) from the feeder lines to isocenter of the magnet

Figure 2-17 Magnet Allowable Milligauss vs. Line Frequency for AC Equipment

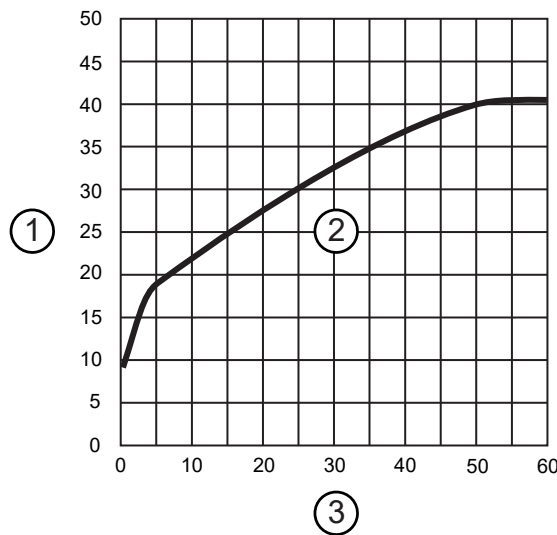

Item	Description	Item	Description
1	Milligauss	3	Excitation Frequency (Hz)
2	No Impact on Imaging		

Refer to [Sample Calculation AC Power Equipment Minimum Distance on page 163](#) for additional examples.

2.6.4 Non-MR System Equipment Sensitivity to Magnetic Fields

Site plans must include consideration for magnetic field interaction with all customer equipment.

This section lists equipment known to be sensitive to high magnetic fields.

Use the table for reference only. The Tesla (Gauss) limits in the table are approximate for that type of equipment. Refer to OEM manuals for the equipment at your site to determine the actual Tesla (Gauss) limits.

Table 2-4 Magnetic Proximity Limits (For Reference Only)

mT (Gauss) Limit	Equipment	
0.05mT (0.5 G)	Nuclear camera	
0.1mT (1 G)	Positron Emission Tomography scanner	Video display (tube)
	Linear Accelerator	CT scanner
	Cyclotrons	Ultrasound
	Accurate measuring scale	Lithotripter
	Analog image intensifiers	Electron microscope
	Bone Densitometers	
0.3mT (3 G)	Power transformers	Main electrical distribution transformers
0.5mT (5 G)	Cardiac pacemakers	Biostimulation devices
	Neurostimulators	
1mT (10 G)	Magnetic computer media	Telephone switching stations
	Hard copy imagers	Water cooling equipment
	Line printers	HVAC equipment
	Video Cassette Recorder (VCR)	Major mechanical equipment room
	Film processor	Credit cards, watches, and clocks
	X-ray tubes	
	Large steel equipment, including:	
	Emergency generators	Air conditioning equipment
	Commercial laundry equipment	Fuel storage tanks
	Food preparation area	Motors greater than 5 horsepower
5mT (50 G)	Metal detector for screening	Telephones
	LCD panels	
No Limit	Digital Detectors	

2.7 Multiple MR System Requirements



(Applies to all subsections within this section)

2.7.1 Multiple Magnets

When installing multiple magnets, the 0.3 mT (3 G) lines must not intersect or the magnets will be interactive. Contact the GE HealthCare Project Manager of Installation (PMI) for any questions regarding magnetic field interaction.

Magnet Rooms cannot share walls.

Figure 2-18 Two Magnet Installation (No Interaction)

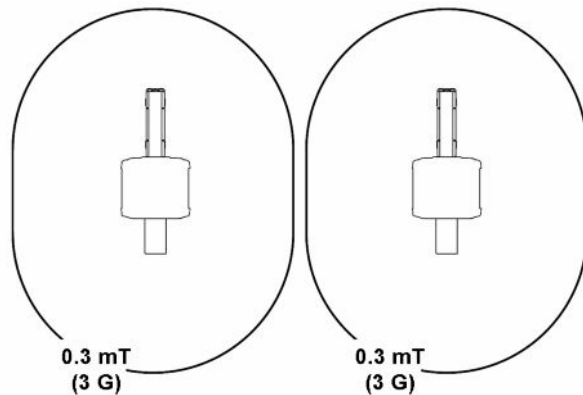

2.7.2 Shared Equipment Rooms

When installing multiple MR Systems in a shared Equipment Room, of the same field strength, the following conditions must be met:

1. The RF cabinet of the existing installed system must be separated from the RF bay of the SC by at least 2000 mm (79 in.).

This requirement does not apply if the existing 1.5T system is one of the following: 1.5T SIGNA HDxt – SIGNA Works Edition (HD28), Brivo MR355/MR360, SIGNA Prime, SIGNA Creator/Explorer, SIGNA Star, SIGNA Star AIR, SIGNA Aviator, SIGNA Aviator AIR, SIGNA MR355/360, SIGNA MR380, SIGNA Victor, SIGNA Prime MAX, SIGNA Prime Elite, SIGNA Voyager, SIGNA Voyager AIR, Discovery MR450, Optima MR450w, SIGNA Artist, SIGNA Artist Evo, SIGNA Winner, or SIGNA Champion.

2. The penetration panel of the other system must be separated from the penetration wall of the SC by at least 3000 mm (118 in.).
3. Cables from different MR Systems must not be routed together.
4. Two systems cannot share common power or ground feeds.

**NOTE**

The distances shown in [Figure 2-19 Cabinet Separations in Shared Equipment Room \(Top View\)](#) on [page 38](#) must be maintained between the RF cabinet of the new system and existing RF cabinet of a non-GE HealthCare MR System. The distance is based on the location of the RF amplifier that is inside the SC, not the location of the SC.

* The 2000 mm (79 in.) requirement does not apply if the existing system is one of those listed in the requirements in [item 1](#) above.

Figure 2-19 Cabinet Separations in Shared Equipment Room (Top View)

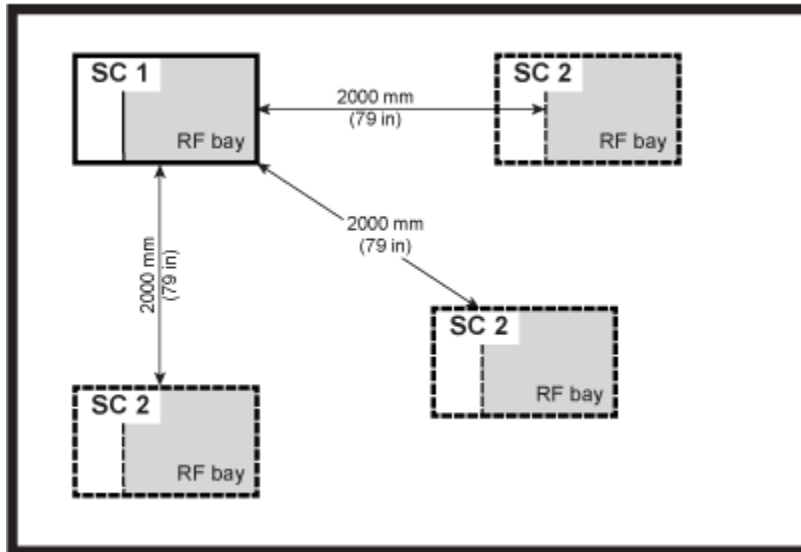

2.8 MR Suite Temperature and Humidity



(Applies to all subsections within this section)

This section provides temperature and humidity requirements for the MR suite.



NOTE

Make sure the HVAC system has the correct capacity for the room size, equipment heat output, and environmental conditions to maintain correct temperature and humidity for the protection of the patient.

Specific construction requirements for each room can be found in the following chapters:

- Magnet Room
- Equipment Room
- Control Room

2.8.1 Temperature and Humidity Requirements

1. The customer is responsible for HVAC system design, purchase, and installation.
2. The temperature and humidity requirements must not be exceeded at any point during the day (both working or non-working hours).
3. A separate thermostat must be provided for the Magnet Room.

Table 2-5 System with Equipment Room

Room	Temperature		Humidity	
	Range °C (°F)	Change °C/Hr (°F/Hr) ¹	Range %RH	Change %RH/Hr ²
Equipment Room at Inlet to Equipment	15-28 (59-82.4) ³	3 (5)	30-75	5
Magnet Room	15-21 (59-69.8)	3 (5)	30-60	5
Control Room	15-32 (59-89.6)	3 (5)	30-75	5
Outdoor (11 kW Airsys Chiller)	-30-43 (-22-110)	-	5-100	-

Notes:

1. Operating temperature gradient limits shall be between -3°C/Hr (-5°F/Hr) and 3°C/Hr (5°F/Hr), when averaged over 1 hour.
2. Operating humidity gradient limits shall be between -5% RH/hour and 5% RH/hour, when averaged over 1 hour.
3. Maximum ambient temperature is derated by 1°C per 300 m above 800 m (not to exceed 2438 m).

Table 2-6 System without Equipment Room

Room	Temperature		Humidity	
	Range °C (°F)	Change °C/Hr (°F/Hr) ¹	Range %RH	Change %RH/Hr ²
Control	15-28 (59-82.4) ³	3 (5)	30-75	5
Magnet Room	15-21 (59-69.8)	3 (5)	30-60	5
Outdoor (11 kW Airsys Chiller)	-30-43 (-22-110)	-	5-100	-

Notes:

1. Operating temperature gradient limits shall be between -3°C/Hr (-5°F/Hr) and 3°C/Hr (5°F/Hr), when averaged over 1 hour.
2. Operating humidity gradient limits shall be between -5% RH/hour and 5% RH/hour, when averaged over 1 hour.
3. Maximum ambient temperature is derated by 1°C per 300 m above 800 m (not to exceed 2438 m).

2.8.2 Equipment Heat Output Specifications

This section details the heat output for specific components. Actual heat output and room temperature may vary due to environmental factors, room insulation, clinical usage, and any non-GE HealthCare equipment used in the MR suite. Also, due to large variations in heat loads, the HVAC system may require unloaders, hot gas bypass, and reheat to maintain humidity levels.



IMPORTANT

For Type A, C, D and E system configuration, BRM / BRM2 is cooled 24 hours a day, even when the SC PDU is in sleep mode. To prevent condensation of BRM/ BRM2, it is required to operate air conditioner in Magnet Room for 24 hours a day, 7 days a week for Type A, C, D and E system configuration.

Table 2-7 System Maximum Heat Output for Air Cooling

Component	Magnet Room W (BTU/hr)	Equipment Room W (BTU/hr)	Control Room W (BTU/hr)
Magnet (MAG)	2400 (8189)		
Blower Box (BB)	1000 (3415)		
System Cabinet (SC)		5000 (17000)*	5000 (17000)*
4 kW LCS (LCS4)			1670 (5695)
8 kW LCS (LCS8)			1670 (5695)
BRM Chiller (BRMC)		4100 (14000)	
Water Chiller for SC (MCS)		5740 (19613)	
Magnet Monitor (MON)		60 (205)*	60 (205)*
Cryocooler Compressor (CRY) -Air Cooled		8240 (28100)	
Cryocooler Compressor (CRY) -Water Cooled		500 (1706)*	500 (1706)*
Main Disconnect Panel (MDP)		264 (900)*	264 (900)*
Step Down Transformer (SDT)		223 (760) x 2	
Operator Workspace (OW)			1450 (4947)



NOTE

* The heat output is generated in one room, depending on the site configurations.

Although the air cooling load averaged over a 12-hour working day is approximately 1/2 of the maximum value, the HVAC system must be sized so that the maximum room gradient, temperature range, temperature change per hour, and humidity specifications per [2.8.1 Temperature and Humidity Requirements on page 39](#) are not exceeded at any point during the working day.

Table 2-8 System Options Heat Output for Air Cooling

Component	Magnet Room W (BTU/hr)			Equipment Room W (BTU/hr)			Control Room W (BTU/hr)		
	Maximum	Average	Idle	Maximum	Average	Idle	Maximum	Average	Idle
MR Elastography (MRE)				141 (480)					

11 kW Airsys Chiller

The 11 kW Chiller is designed to locate external to the building. The following is heat output information of 11 kW Airsys Chiller.

11 kW Airsys Chiller: 15400 Watt (50500 BTU/hr)

2.9 Facility Coolant Requirements



(Applies to all subsections within this section)

The BRM and SC cooling circuits must be supplied only by GE-supplied equipment. Emergency bypass cooling circuits cannot connect directly to the BRM or SC.

2.9.1 Type A Configuration

This configuration consists of two 11 kW Chillers. One 11 kW Chiller (WC1) provides chilled water for 8 kW LCS (LCS8) and gradient coil (BRM). The other 11 kW Chiller (WC2) provides chilled water for Cryocooler Compressor (CRY). Supply and return water hose for both chillers are connected the Cryocooler Compressor to provide emergency backup coolant. Valves in the water hose are normally closed, manually open it in emergency situation to make sure the compressor is cooled.

Water hoses coming from one 11 kW Chiller (WC1) are spited into two loops at the T-shape joint. One loop provides coolant to the 8KW LCS in the equipment room, the other loop passes through the penetration panel (PP) to cool down the gradient coil.

The 8 kW LCS provides a dedicated closed water loop for System Cabinet (SC) and must be located at the same level of the System Cabinet.

Figure 2-20 Type A Chiller Configuration

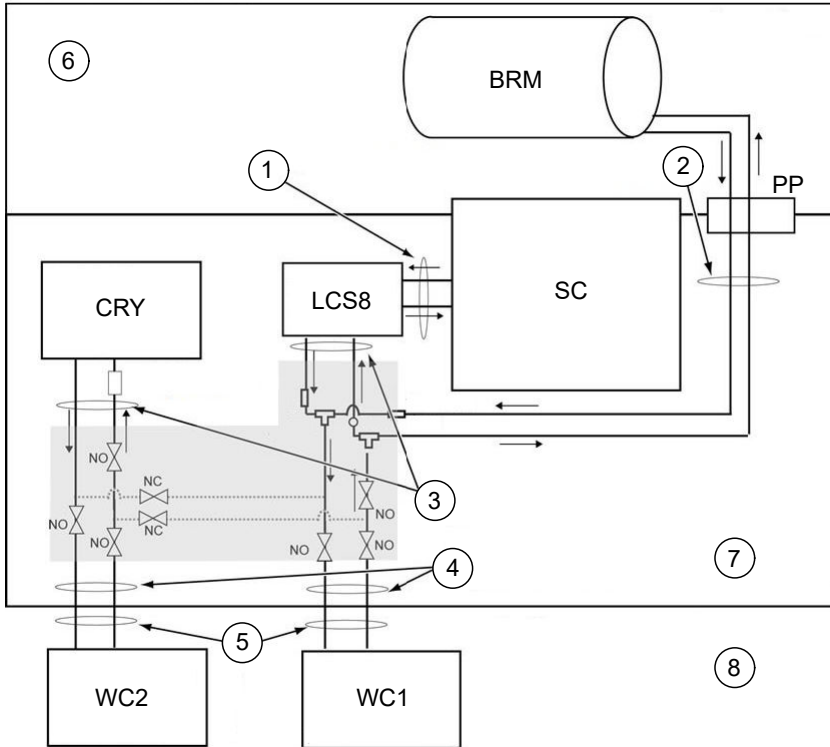

Symbol	Name	Item	Description
.....	Backup line	NO	Normally Open
	Valve	NC	Normally Closed
	Water Flow Meter		Joint
1	1" Hose: 5151845-2, use 'Coolant for Cabinet' (5410510) supplied by GE.	2	½" Hose: 5727409
3	½" hose supplied with 11 kW chiller, use coolant for BRM-yellow color (2297672) supplied with 11 kW chiller.	4	¾" rubber hose for indoor supplied with 11 kW chiller
5	¾" outdoor pipe and insulation (supplied by customer)	6	Magnet Room
7	Equipment Room	8	Outdoor



NOTE

The grey area indicates the Plumbing Assembly (5343094).

Joints, valves, water meters are included in Plumbing Assembly supplied by GE.

For outdoor, copper or PP-R pipe/joint/valve is recommended which satisfies the following requirements:

1. Working temperature: -30 °C ~ 90 °C
2. Working pressure: ≥ 1.6 Mpa
3. Material should be propylene glycol (50%) resistant.
4. All pipes installed outdoor should be insulated.

Figure 2-21 Plumbing Assembly for Type A

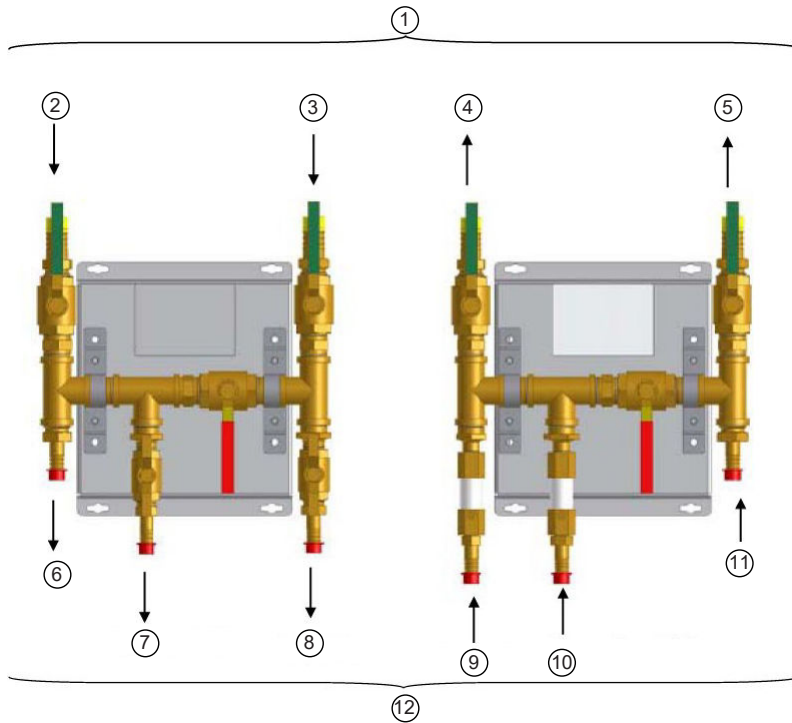

Item	Description	Item	Description
1	Hose Inner Diameter = ¾"	2	From 11kW Chiller #1 (WC1)
3	From 11kW Chiller #2 (WC2)	4	To 11kW Chiller #1 (WC1)
5	To 11kW Chiller #2 (WC2)	6	To BRM
7	To 8kW LCS (LCS8)	8	To Cryocooler Compressor
9	From BRM	10	From 8kW LCS (LCS8)
11	From Cryocooler Compressor	12	Hose Inner Diameter = ½ "

2.9.2 Type B Configuration

This configuration uses the facility water for Cryocooler Compressor (CRY), 8 kW LCS (LCS8), and 4 kW LCS (LCS4). This water must meet the specification described in [2.9.7 Site Provided Facility Chilled Water or Local Chiller Requirements - Type B \(B'\) Configuration on page 54](#).

The two flexible hoses (supply and return) are to be routed from the facility water. Each hose is separated into three hoses by T-Shape joints. One hose set (supply and return lines) is connected to Cryocooler Compressor. The second hose set (supply and return lines) is connected to 8 kW LCS. The third hose set (supply and return lines) is connected to 4 kW LCS.

The 8 kW LCS and 4 kW LCS are an indoor dedicated and must be located at the same level of System Cabinet (SC). 8 kW LCS provides water for System Cabinet. 4 kW LCS provides water routed through the penetration panel (PP) to cool down the gradient coil (BRM).

Figure 2-22 Type B Chiller Configuration

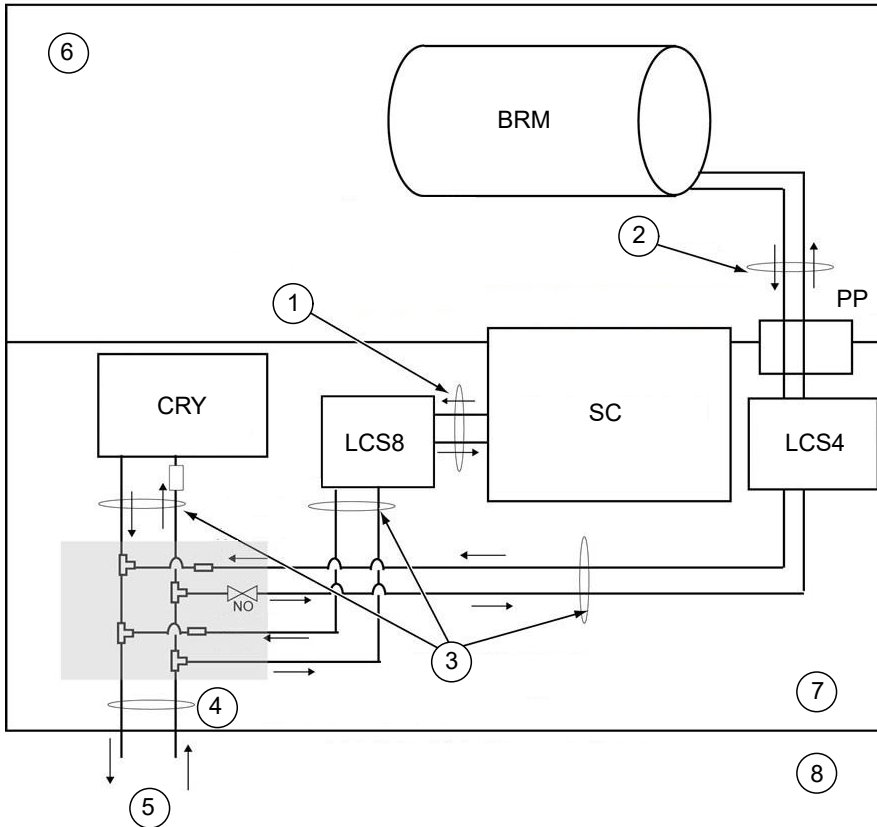

Symbol	Name	Item	Description
	Valve		Water Flow Meter
NO	Normally Open		Joint
NC	Normally Closed	1	1" Hose (5151845-2), use 'Coolant for Cabinet' (5410510) supplied by GE.
2	1/2" Hose (5727409) Use Coolant for BRM (pink color 2138791) supplied by GE.	3	1/2" Hose (5727409) supplied by GE.
4	3/4" Hose supplied by customer.	5	Facility Water
6	Magnet Room	7	Equipment Room
8	Outdoor	-	-



NOTE

The grey area indicates the Plumbing Assembly (5343093).

Joints, valves, water meters, water filters are included in Plumbing Assembly supplied by GE.

For mobile configuration, use coolant (2138791) supplied by GE for 8 kW LCS.

Figure 2-23 Plumbing Assembly for Type B and B'

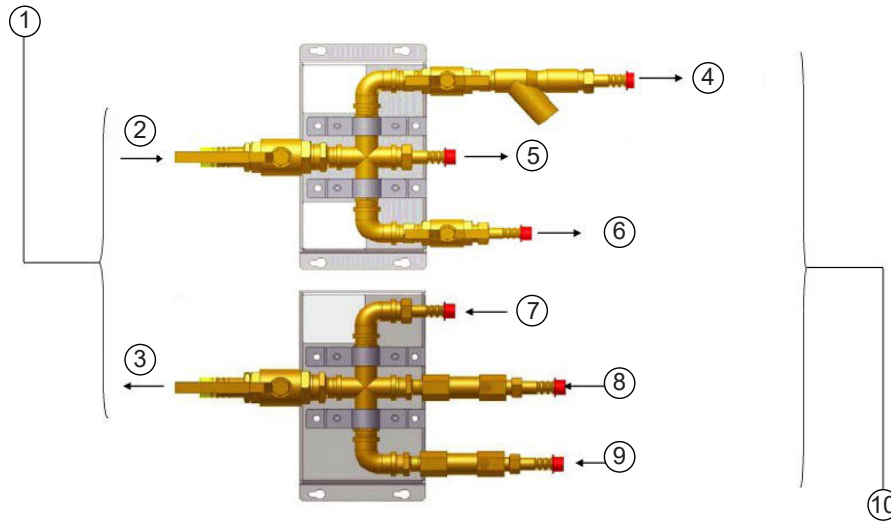

Item	Description	Item	Description
1	Hose Inner Diameter = 3/4"	2	Facility Water Supply
3	Facility Water Return	4	To Cryocooler Compressor
5	To 4kW LCS	6	To 8kW LCS
7	From Cryocooler Compressor	8	From 4kW LCS
9	From 8kW LCS	10	Hose Inner Diameter = 1/2 "

2.9.3 Type B' Configuration

This configuration uses customer supplied 20 kW Local Chiller for Cryocooler Compressor (CRY), 8 kW LCS (LCS8), and 4 kW LCS (LCS4). The Local 20 kW Chiller must meet the specification described in [2.9.7 Site Provided Facility Chilled Water or Local Chiller Requirements - Type B \(B'\) Configuration on page 54](#).

The two flexible hoses (supply and return) are to be routed from the 20 kW Local Chiller. Each hose is separated into three hoses by T-Shape Joints. One hose set (supply and return lines) is connected to Cryocooler Compressor. The second hose set (supply and return lines) is connected to 8 kW LCS. The third hose set (supply and return lines) is connected to 4 kW LCS.

The 8 kW LCS and 4 kW LCS are an indoor dedicated and must be located at the same level of System Cabinet (SC). 8 kW LCS provides water for System Cabinet. 4 kW LCS provides water routed through the penetration panel (PP) to cool down the gradient coil (BRM).

Figure 2-24 Type B' Chiller Configuration

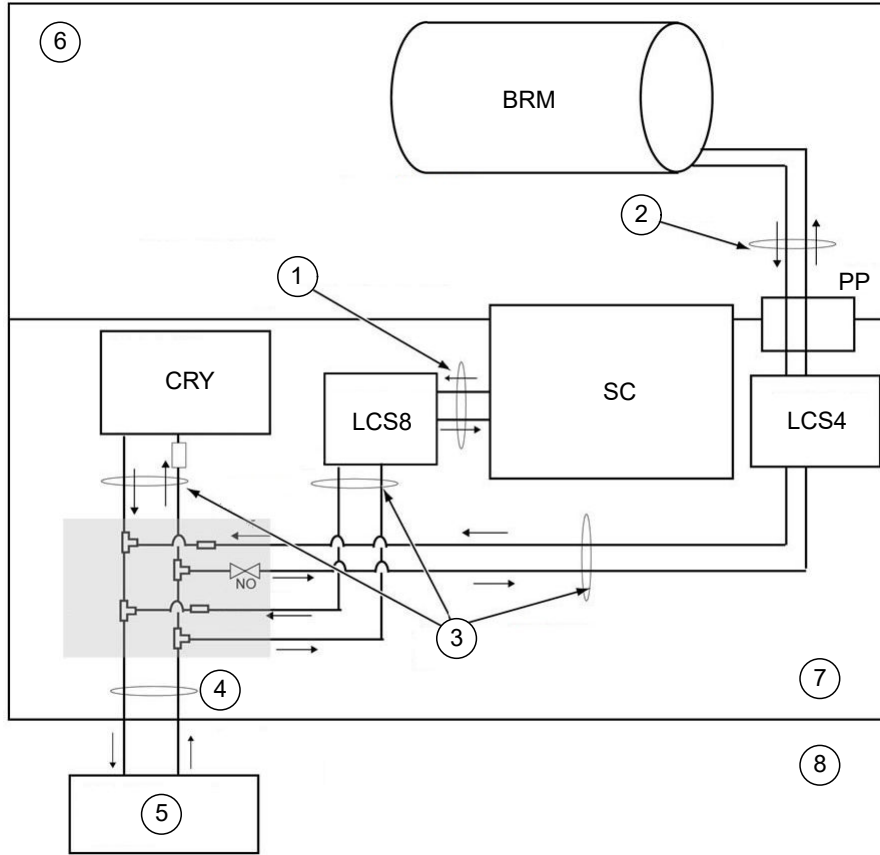

Symbol	Name	Item	Description
	Valve		Water Flow Meter
NO	Normally Open		Joint
NC	Normally Closed	1	1" Hose (5151845-2), use 'Coolant for Cabinet' (5410510) supplied by GE.
2	½" Hose (5727409) Use Coolant for BRM (pink color 2138791) supplied by GE.	3	½" Hose (5727409) supplied by GE.
4	¾" Hose and coolant supplied by customer.	5	20 kW Local Chiller
6	Magnet Room	7	Equipment Room
8	Outside	-	-



NOTE

The grey area indicates the Plumbing Assembly (5343093).

Joints, valves, water meters, water filters are included in Plumbing Assembly supplied by GE.

For the detail of Plumbing Assembly for Type B', refer to [Figure 2-23 Plumbing Assembly for Type B and B' on page 47](#).

2.9.4 Type C Configuration



The 11 kW Chiller (WC1) provides water for Cryocooler Compressor (CRY) and gradient coil (BRM).

The supply and return lines of 11 kW Chiller are split into two hoses by T-Shape joints. One hose set (supply and return lines) is connected to Cryocooler compressor. The other hose set (supply and return lines) is routed through waveguides in the Penetration Panel (PP), through the Rear Pedestal, and connected to the rear of the Gradient Coil with supplied adjustable compression clamps.

The two flexible hoses (supply and return) are to be connected from the MCS to the System Cabinet (SC).

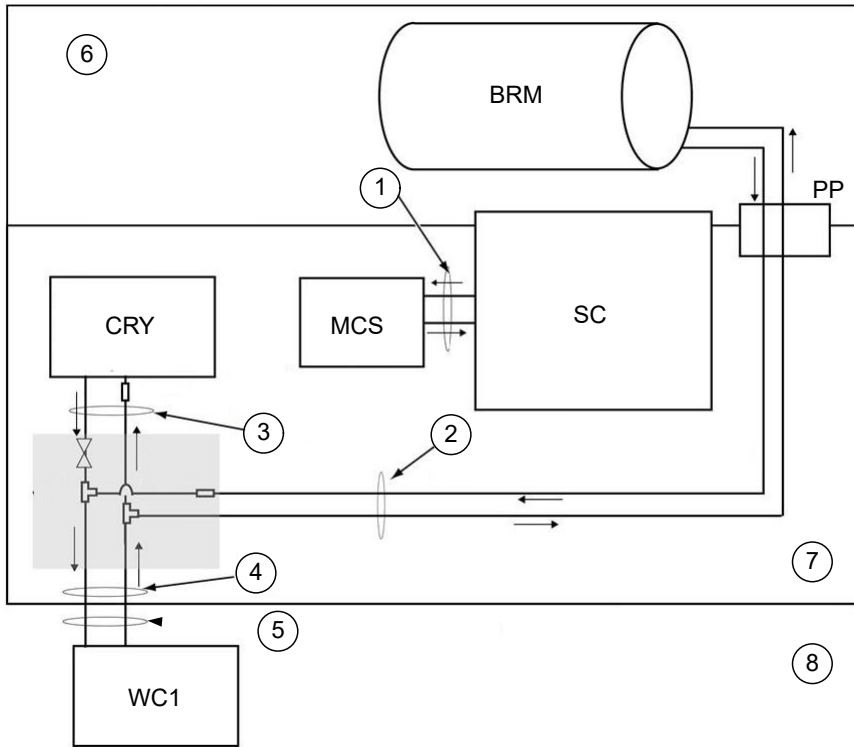
Figure 2-25 Type C Chiller Configuration



Symbol	Name	Item	Description
NO	Normally Open		Valve
NC	Normally Closed		Joint
	Water Flow Meter	1	1" Hose (5151845-2), use 'Coolant for Cabinet' (5410510) supplied by GE.
2	½" Hose (5727409) Use Coolant (yellow color 2297672) supplied with 11 kW chiller.	3	½" Hose supplied with 11 kW chiller.
4	¾" rubber hose for indoor supplied with 11 kW chiller.	5	¾" outdoor pipe and insulation supplied by customer.
6	Magnet Room	7	Equipment Room
8	Outdoor	-	-



NOTE

The grey area indicates the Plumbing Assembly (5343091).

Joints, valves, water meters are included in Plumbing Assembly supplied by GE.

For outdoor, copper or PP-R pipe/joint/valve is recommended which satisfies the following requirement:

1. Working temperature: -30 °C ~ 90 °C
2. Working pressure: ≥ 1.6 Mpa
3. Material should be propylene glycol (50%) resistant.
4. All pipes installed outdoors should be insulated.

Figure 2-26 Plumbing Assembly for Type C

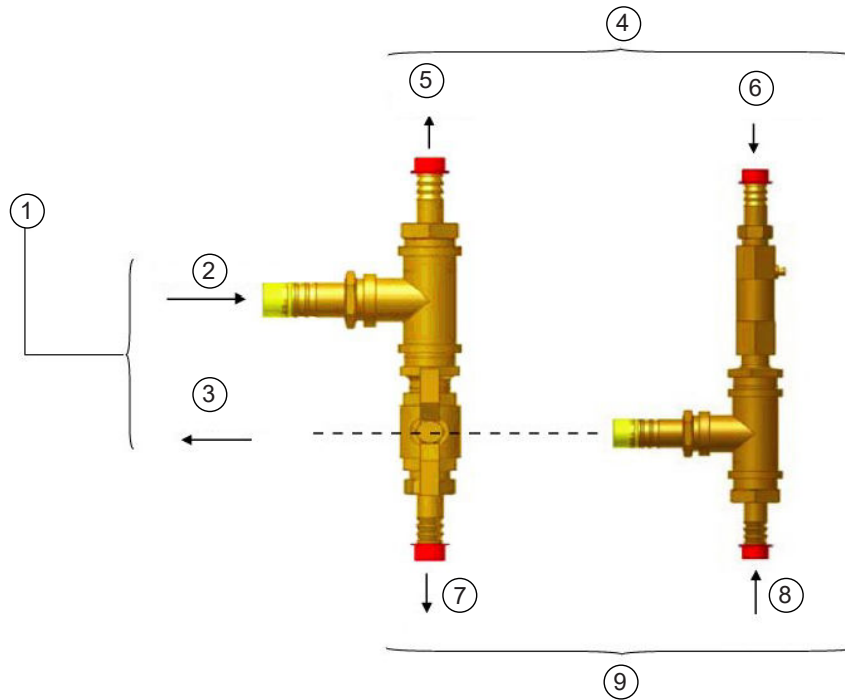

Item	Description	Item	Description
1	Hose Inner Diameter = ¾" (Hoses: supplied by customer)	2	From 11 kW Chiller (WC1)
3	To 11 kW Chiller (WC1)	4	Hose Inner Diameter = ½ "
5	To BRM	6	From BRM
7	To Cryocooler Compressor	8	From Cryocooler Compressor
9	Hose Inner Diameter = ½ "	-	-

2.9.5 Type D Configuration

Two flexible hoses (supply and return) are to be routed from the BRM Chiller through waveguides in the Penetration Panel (PP), through the Rear Pedestal, and connected to the rear of the Gradient Coil (BRM) with supplied adjustable compression clamps.

The BRM Chiller for Gradient Coil must not be located below the Magnet Room floor level. The BRM Chiller reservoir tank has a low pressure vent plug which relieves pressure from thermal expansion of water and activates when tank pressure reaches 3-5 psi (0.2-0.3 bar). The vent plug could allow fluid to leak if located below the MR System level. The reservoir tank vented plug can not be replaced with a non-vented type, damage to the tank may occur.

Two hoses (supply and return) are connected from the MCS to the System Cabinet (SC). The MCS must be located at the same level of the System Cabinet.

Figure 2-27 Type D Chiller Configuration

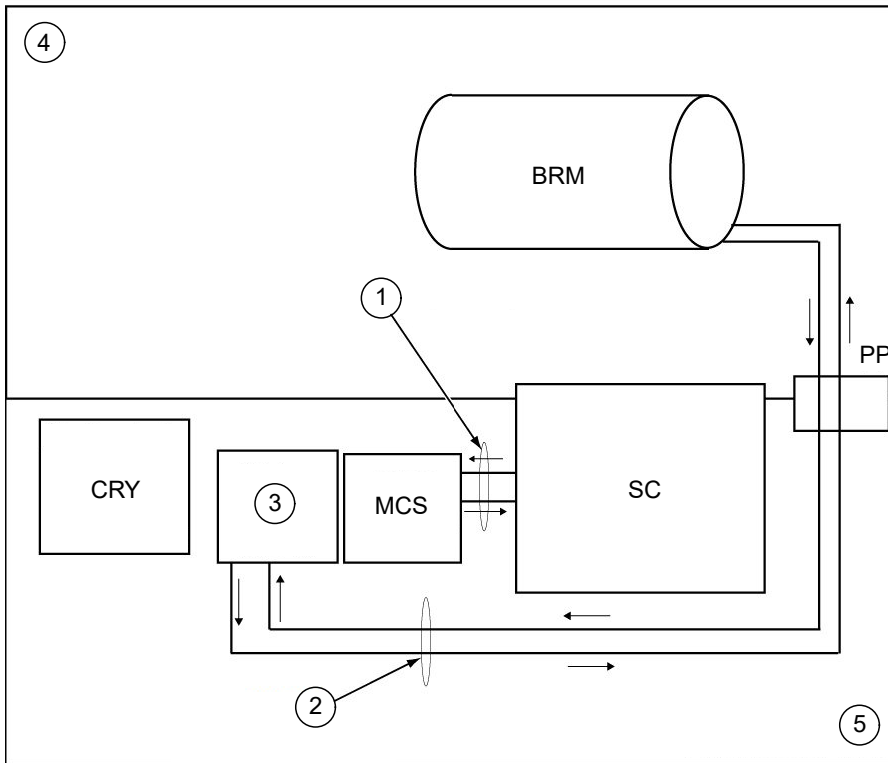

Item	Description	Item	Description
1	1" Hose (5151845-2), use 'Coolant for Cabinet' (5410510) supplied by GE.	2	½" Hose (5727409) Use Coolant for BRM (pink color 2138791) supplied by GE.
3	BRM Chiller	4	Magnet Room
5	Equipment Room	-	-

2.9.6 Type E Configuration

Two flexible hoses (supply and return) are to be routed from the BRM Chiller through waveguides in the Penetration Panel (PP), through the Rear Pedestal, and connect to the rear of the Gradient Coil (BRM) with supplied adjustable compression clamps.

The BRM Chiller for Gradient Coil must not be located below the Magnet Room floor level. The BRM Chiller reservoir tank has a low pressure vent plug which relieves pressure from thermal expansion of water and activates when tank pressure reaches 3-5 psi (0.2-0.3 bar). The vent plug could allow fluid to leak if located below the MR System level. The reservoir tank vented plug can not be replaced with a non-vented type, damage to the tank may occur.

Two hoses (supply and return) are connected from MCS to the System Cabinet (SC). MCS must be located at the same level of the System Cabinet.

Figure 2-28 Type E Chiller Configuration

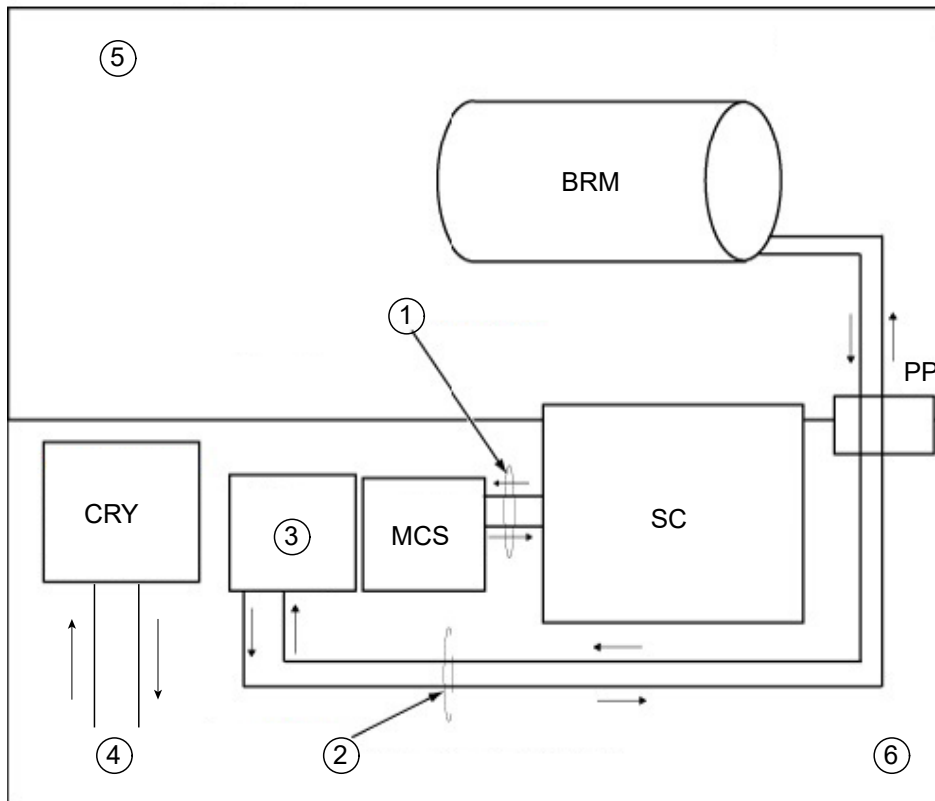

Item	Description	Item	Description
1	1" Hose (5151845-2), use 'Coolant for Cabinet' (5410510) supplied by GE.	2	½" Hose (5727409) Use Coolant for BRM (pink color 2138791) supplied by GE.
3	BRM Chiller	4	Facility Water
5	Magnet Room	6	Equipment Room

2.9.7 Site Provided Facility Chilled Water or Local Chiller Requirements - Type B (B') Configuration

The customer provided water cooling system must be closed loop design. The water cooling design can utilize open loop city water, with required filtering, only as temporary backup during loss of closed loop water cooling system. Open loop systems will not allow a chemical equilibrium to be established resulting in continual build up or etching to take place which will eventually contribute to failure. Water system capacity must be selected to insure adequate reserve for overcoming all pressure drops and still maintain the required flow rate.



NOTE

Continuous water cooling is critical for the MR System and therefore **MUST** be available 24 hours per day / 7 days per week / 365 days per year to maximize correct uninterrupted magnet operation. Water cooling is required immediately upon magnet arrival, temporary water cooling must be provided if permanent site water cooling is not available.

The closed loop system may be shared with other equipment in the MR suite. The number of sharing systems should be kept to as low as possible in order to minimize contamination and reliability problems. Flow gauges and valves are recommended at all branch lines to control distribution and allow servicing of equipment.

- A flow meter must be permanently installed in system by customer.

Table 2-9 Facility Chilled Water or Local Chiller Requirement

Parameter	Requirements
Availability	Continuous
Chiller Size ¹	Minimum 20 kW
Minimum Continuous Heat Load	7.5 kW
Inlet Temperature to LCS/Cryocooler Compressor	44.6 to 59°F (7 to 15°C) measured at the inlet to the LCS/Cryogen compressor
Inlet Pressure of LCS/Cryocooler Compressor	Minimum 40 psi (280 kpa), Maximum 100 psi (690 kpa)
Maximum Flow	18.5 gpm (70 L/min)
Minimum Flow	9.5 gpm (36 L/min)
Temperature rise at Maximum Flow	9°F (5°C) with 50% propylene glycol or ethylene glycol-water; 20 kW heat
Temperature rise at Minimum Flow	18°F (10°C) with 50% propylene glycol or ethylene glycol-water; 20 kW heat
Antifreeze	No more than 50% propylene glycol-water (PGW) or ethylene glycol-water (EGW)
Facility Filter	150 micron or smaller with a field-changeable filter
Customer supplied hose connections to the LCS/Cryocooler compressor	3/4 inch
Condensation Protection ²	Condensation must be managed to prevent equipment damage or safety hazards.

Table 2-9 Facility Chilled Water or Local Chiller Requirement (Table continued)

Parameter	Requirements
Notes:	
1. Minimum 20 kW should be based on local max. environment temperature.	
2. Hose insulation between facility water and 8 kW LCS, 4 kW LCS and Cryocooler Compressor will be supplied by customer.	

Table 2-10 Facility Water Quality Requirements

Parameter	Requirement
pH Value	6.5 to 8.2 at 25 °C (77 °F)
Electrical Conductivity	< 0.8 mmho/cm
Chloride Ion	< 200 ppm
Sulfate Ion	< 200 ppm
M-Alkalinity	< 100 ppm
Total Hardness	< 200 ppm
Calcium Hardness	< 150 ppm
Ionic Silica	< 50 ppm
Iron	< 1.0 ppm
Copper	< 0.3 ppm
Sulfide Ion	None, not detectable
Ammonium Ion	< 1.0 ppm
Residual Chlorine	< 0.3 ppm
Free Carbon Dioxide	< 4.0 ppm
Stability Index	6.0 to 7.0
Suspended Matter	< 10 ppm
Particle Size	< 100 micron (with field changeable filter)

2.9.8 Facility Coolant Requirements - Type E Configuration

Figure 2-29 Cryocooler Compressor Typical Flow Characteristics

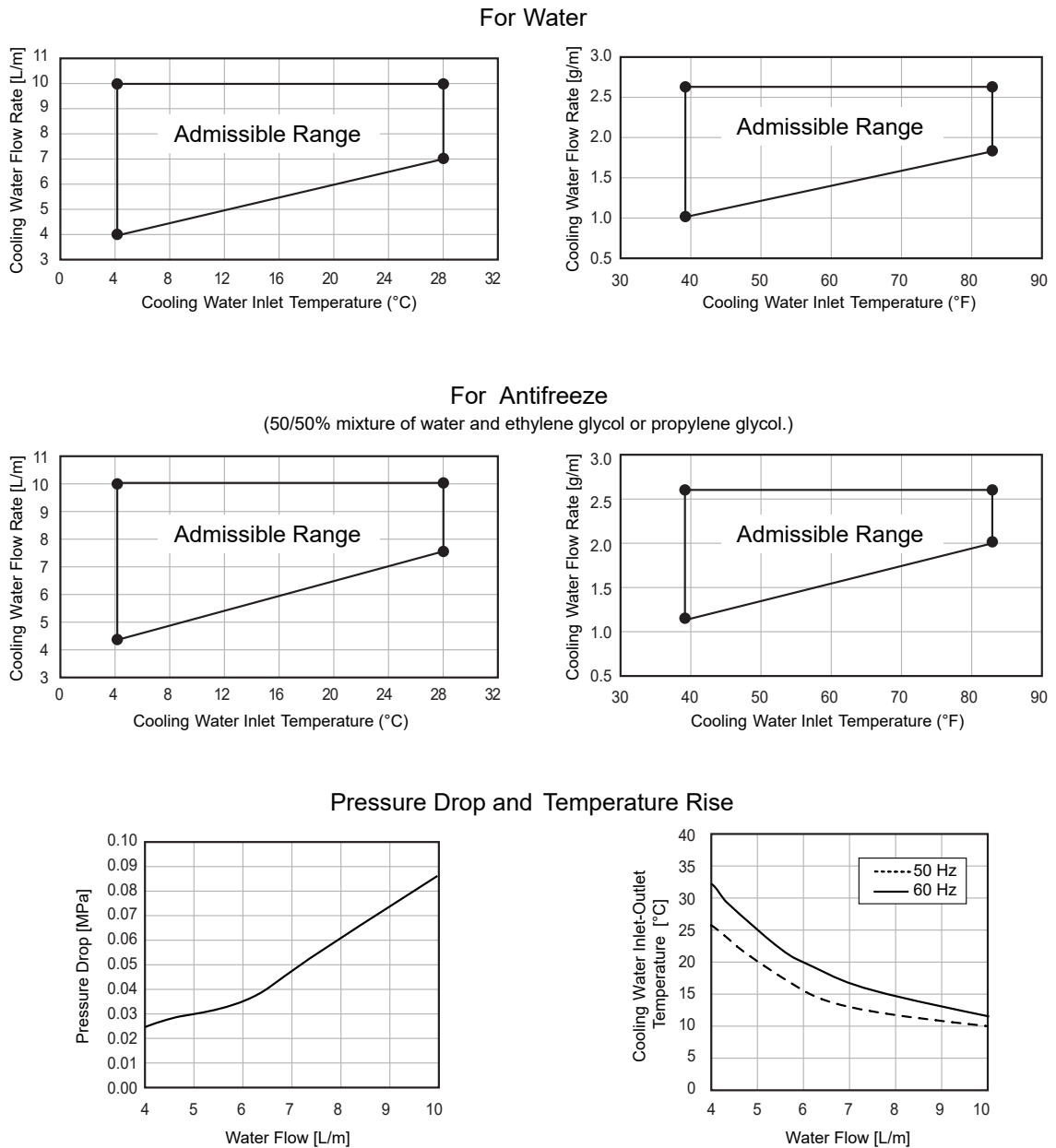

Table 2-11 Cryocooler Compressor Coolant Requirements

Parameter	Requirements
Inlet Temperature Range [deg.C] (deg.F)	[4.0 ~ 28.0] (39.2 ~ 82.4)
Inlet Pressure Range [MPa] (psig)	[0.20 ~ 0.69] (29 ~ 100)
Flow Rate [liter/min.] (gallon/min.)	[4.0 ~ 10.0] (1.1 ~ 2.6)
Pressure Drop [MPa] (psig)	[0.025 ~ 0.085] (3.55 ~ 12.1)

Table 2-11 Cryocooler Compressor Coolant Requirements (Table continued)

Parameter	Requirements
Heat Output [kW] (BTU/Hr)	Steady State [< 6.5] (< 22180) for 50Hz [< 7.5] (< 25590) for 60Hz Maximum [< 7.2] (< 24570) for 50Hz [< 8.3] (< 28320) for 60Hz

Table 2-12 Facility Water Quality Requirements

Parameter	Requirement
pH Value	6.5 to 8.2 at 25 °C (77 °F)
Electrical Conductivity	< 0.8 mmho/cm
Chloride Ion	< 200 ppm
Sulfate Ion	< 200 ppm
M-Alkalinity	< 100 ppm
Total Hardness	< 200 ppm
Calcium Hardness	< 150 ppm
Ionic Silica	< 50 ppm
Iron	< 1.0 ppm
Copper	< 0.3 ppm
Sulfide Ion	None, not detectable
Ammonium Ion	< 1.0 ppm
Residual Chlorine	< 0.3 ppm
Free Carbon Dioxide	< 4.0 ppm
Stability Index	6.0 to 7.0
Suspended Matter	< 10 ppm
Particle Size	< 100 micron (with field changeable filter)

2.9.9 Cryocooler Compressor Temporary Backup Water Requirement - Type B, C, E



NOTE

This section applies to indoor shield cooler compressor for cooling type B, C, and E.

The customer must balance the cost of cryogenics and local controls with the cost of emergency backup facility coolant. The backup cooling design can utilize open loop city water only as temporary backup during loss of the closed loop water cooling from the 11 kW AirSys chiller or customer provided water cooling to the Cryocooler Compressor. Long term open loop systems will not allow a chemical equilibrium to be established resulting in continual build up or etching that can take place which will eventually contribute to failure. Water system capacity must be selected to make sure adequate reserve for overcoming all pressure drops and still maintain the required flow rate for the Cryocooler

Compressor Cabinet. Refer to [2.9.7 Site Provided Facility Chilled Water or Local Chiller Requirements - Type B \(B'\) Configuration on page 54](#) for water cooling specifications.

**NOTE**

These water cooling specifications are the requirements at the equipment. The backup cooling system design must have allowances for pressure or temperature changes due to distance located from the Cryocooler Compressor.

CAUTION

SWITCHING THE CRYOCOOLER COMPRESSOR INLET/OUTLET COOLING FROM THE 11 KW AIRSYS CHILLER TO A TEMPORARY WATER BACKUP SUPPLY WILL RESULT IN APPROXIMATELY 1.5 GALLONS (5.5 LITERS) OF 50% MIXTURE OF DOWFROST HD AND DE-IONIZED WATER BEING DISCHARGED. THIS DISCHARGE MAY HAVE SITE IMPACTS DUE TO LOCAL REGULATORY CODES. MAKE SURE TO UNDERSTAND AND FOLLOW LOCAL REGULATORY REQUIREMENTS WHEN DESIGNING AND IMPLEMENTING A TEMPORARY BACKUP WATER SYSTEM. THE DESIGN OF THE CHANGE OVER EQUIPMENT FROM 11 KW AIRSYS CHILLER TO CITY WATER AND VISE-A-VERSA MUST NOT ALLOW CONTAMINATION OF THE CLOSED LOOP SYSTEM IN THE 11 KW AIRSYS CHILLER.

2.9.10 11 kW Chiller Requirements

11 kW Chiller Interconnects/Separation Limitations

Location of the 11 kW Chiller must meet the following limitations for the water lines:

- Outdoor water line (pipe) must be thermally insulated.
- Maximum vertical separation is not to exceed 30000 mm (1181 in) with the 11 kW Chiller above the MR System or 3000 mm (118.1 in) with the 11 kW Chiller below the MR System.
- 11 kW Chiller and the Remote Control Panel (RCP) must not be separated by a distance greater than 30500 mm (1200 in) total interconnect length.
- Distance should be less than 30000 mm (1181 in) between chiller and equipment room, if use 3/4" piping between outdoor chiller and indoor unit.
- Distance between chiller and equipment room can be > 30000 mm, if use >3/4" piping between outdoor chiller and indoor unit. Please consult GE or Airsys for details.
- If the length between remote controller and chiller is longer than 30000 mm (1181 in), order 100000 mm (3937 in) cable from option list.

11 kW Chiller Access & Air Considerations

Ensure there is easy access to the top cover of the unit. The air inlet and outlet are located on the unit front and rear respectively. Restricting airflow into or out of the 11 kW Chiller will impair performance. The minimum clearances shown in [11 kW Chiller on page 128](#) are required on each side and top to ensure adequate airflow.

An 11 kW Chiller unit installed in a high airflow area may be affected by the seasonal winds. In such environments it is recommended to install wind breaks for the 11 kW Chiller.

11 kW Chiller Outdoor Installation Mounting

The 11 kW Chiller must be located on a strong, level surface, see [11 kW Chiller on page 128](#) for concrete pad requirements for one 11 kW Chiller unit. A chiller mounted on a slab on grade or rooftop will have

the casters removed and be bolted down using the six middle holes shown in 11 kW Chiller Outdoor Mounting illustration in [11 kW Chiller on page 128](#) to rigidly mount the unit.

Responsibility for Installation Tasks for 11 kW Chiller Equipment

The 11 kW Chiller subsystem equipment installation requires specific tasks to be performed by the Customer Contractor, GE Service, and Service Provider (dependent on site location Service provider, refer to [Table 2-14 11 kW Chiller Service Providers on page 59](#)). [Table 2-13 11 kW Chiller Equipment Installation Tasks Responsibility on page 59](#) lists the responsibility for the specific tasks. Refer to vendor manual for additional information concerning tasks.

Table 2-13 11 kW Chiller Equipment Installation Tasks Responsibility

11 kW Chiller Equipment Responsibility For Installation Tasks When Used for Cryocooler Compressor Prior to Magnet Delivery & When Magnet Is Delivered/Installed			
Task	Responsible to Perform Task		
	Customer	GE	Service Provider ¹
Unload chiller from truck	X		
Move chiller to Equipment Room or outdoor concrete pad and mount in accordance with local codes	X		
Connect customer supplied power cable from facility power supply or MDP to Chiller	X		
Install water lines to chiller, and no leaks	X		
Install Remote Control and cable in Operation Room, and connect remote controller cable to chiller.	X		
Fill chiller with glycol ²			X
Start chiller, verify correct phase rotation and no leaks found			X
Perform final Inspection of chiller and verify correct operation			X
Attach labels			X
Fullfill Start-up report			X
Installation Verification		X	X
Notes:			
1. The Service Providers are listed in Table 2-14 11 kW Chiller Service Providers on page 59 .			
2. Only for US, customer shall take responsibility to fill chiller with Glycol.			

Table 2-14 11 kW Chiller Service Providers

Location	Service Provider Address	Telephone	Fax/Email
U.S, Canada, & Latin America	GE HealthCare, 3200 N Grandview Blvd, Waukesha, WI 53188	+1 800 437 1171	
Europe & other countries	The Competitive Advantage, Italy 27100 Pavia Via Sacco 7	+39 382 303 990	Roberto@cacioli.191.it
India	India Service Center	+91 33 2251 7220	+91 22 6645 9287 cc-india@air-sys.com

Table 2-14 11 kW Chiller Service Providers (Table continued)

Location	Service Provider Address	Telephone	Fax/Email
Asia and all other countries	AIRSYS, No.28, East LuGu St, Shijing-shan Dist. Beijing P.R. China 100040	+86 10 400 820 5515 +86 10 6865 6161	86-10-68652453

2.10 MR Suite Electrical Requirements



(Applies to all subsections within this section)

2.10.1 General Electrical Requirements

1. Customer is required to install a Main Disconnect Panel (MDP):
 - 1.1. For GE HealthCare supplied MDP, M50022MB and M50022MC Design setup, see [2.10.2 GE HealthCare Supplied Main Disconnect Panel \(MDP\) Specifications for M50022MB and M50022MC on page 64](#).
 - 1.2. For Customer-supplied MDP:
 - 1.2.1. Customer-supplied MDP may not be permissible in all regions. Contact your GE HealthCare Project Manager of Installation (PMI) to verify local requirements.
 - 1.2.2. MDP Design Requirements: [2.10.3 Customer-supplied Main Disconnect Panel \(MDP\) Requirements \(exempt countries only*\) on page 70](#).
 - 1.2.3. MDP Design Setup [Figure 2-35 Customer-supplied MDP Setup for Type A on page 72](#), [Figure 2-36 Customer-supplied MDP Setup for Type B on page 73](#), [Figure 2-37 Customer-supplied MDP Setup for Type C on page 74](#), [Figure 2-38 Customer-supplied MDP Setup for Type D on page 75](#), and [Figure 2-39 Customer-supplied MDP Setup for Type E on page 76](#).
2. At least one remote Emergency Off push-button shall be installed in a location that is visible and accessible to the device operator (Control Room or Magnet Room). The push-button shall be normally closed and require operator action to release after activation (for example, twist and pull). GE HealthCare recommends installing two remote Emergency Off push buttons, installed in the Control Room and Magnet Room.
3. The facility must provide system power to the MDP.
4. All associated transformers and cables must be correctly sized for system power requirements.
5. Runs E0501, E0503, E0507, E0009, E3500, and M3527 are supplied by GE HealthCare. All other wiring shown in [2.10.2 GE HealthCare Supplied Main Disconnect Panel \(MDP\) Specifications for M50022MB and M50022MC on page 64](#) and [2.10.3 Customer-supplied Main Disconnect Panel \(MDP\) Requirements \(exempt countries only*\) on page 70](#) must be customer supplied and installed. A customer-supplied substitute for E0009, can be used if the supplied run is shorter than required.
6. All feeder circuits require dedicated ground wires.

Table 2-15 Facility Power Requirements

Component	Parameter	Requirements	
At Main Disconnect Panel (MDP)	Voltage / Frequency	480 VAC	60 ±3 Hz
		415 VAC	50 ±3 Hz, 60 ±3 Hz
		400 VAC	50 ±3 Hz, 60 ±3 Hz
		380 VAC	50 ±3 Hz, 60 ±3 Hz

Table 2-15 Facility Power Requirements

Component	Parameter	Requirements	
		208 VAC	50 ±3 Hz, 60 ±3 Hz
		200 VAC	50 ±3 Hz, 60 ±3 Hz
	Daily Voltage Variation	Customer to provide +10% / -10% from nominal at MDP input under all line and load conditions. This includes variation of power source and transmission losses up to the MDP.	
	Phase	Input power to the MDP may use one of the following configurations: <ul style="list-style-type: none"> A 3 phase solidly grounded WYE with Ground (3 Wire + Ground) A neutral conductor is not required for MR System operation. If a neutral conductor is present, it can be terminated on the neutral bus provided in the GE HealthCare-supplied MDP. A 3 phase floating DELTA with Ground (3 Wire + Ground). Do not connect a corner grounded DELTA source. <p> NOTE Some UPS options may require a neutral (refer to manufacturer documentation for requirements).</p>	
	Phase Balance	Difference between the highest phase line-to-line voltage and the lowest phase line-to-line voltage must not exceed 2%	
	Power Quality	Recommended THD-V of less than 2.5%	
	Facility Zero Voltage Reference Ground	<ul style="list-style-type: none"> The facility ground for the MR System must originate at the system power source (that is, transformer or first access point of power into the facility) and be continuous to the MR System Main Disconnect Panel (MDP) in the room. Main facility ground conductor to Main Disconnect Panel (MDP) must be appropriately sized insulated copper wire. The main facility ground to the Main Disconnect Panel (MDP) must meet local codes. 	
	Power Availability	Continuous facility power is required at all times for operation of the Cryocooler (CRY) to minimize cryogen consumption.	
Service receptacle in Magnet Room	Voltage / Frequency	100-120 VAC 60 Hz (North America) 200-240 VAC 50/60 Hz (International)	Receptacle required for small power tools. Local voltage and portable transformers for voltage values.
	Phase	1	
	Maximum Current	20A (North America) 16A (International)	
Pneumatic Patient Alert (PA1)	Voltage / Frequency	100-120 VAC 60 Hz (North America) 200-240 VAC 50/60 Hz (International)	The Control Box must be mounted within reach of the operator and within 1.5 m (5 ft.) of an electrical outlet.
	Phase	1	
	Maximum Current	20A (North America) 16A (International)	

Table 2-15 Facility Power Requirements (Table continued)

Component	Parameter	Requirements	
Magnet Rundown Unit (MRU)	Voltage / Frequency	100-120 VAC 60 Hz (North America) 200-240 VAC 50/60 Hz (International)	Connection type: Hardwired or permanently wired directly to facility power, no plugs or connectors allowed. 25 mm (1 in.) PVC Schedule 40 Conduit recommended Availability: Continuous Circuit Breaker: Dedicated AC disconnect required for both live and neutral connections
	Phase	1	
	Maximum Current	1A	
Magnet Monitor (MON)	Voltage / Frequency	100-120 VAC 60 Hz (North America) 200-240 VAC 50/60 Hz (International)	Power at the outlet must be continuously available.
	Phase	1	
	Maximum Current	3A	
Optional MRE Re-soundant Acoustic Driver	Voltage / Frequency	100-120 VAC 60 Hz (North America) 200-240 VAC 50/60 Hz (International)	
	Phase	1	
	Maximum Current	20A (North America) 16A (International)	
Oxygen Monitor (OXY) Option	Voltage / Frequency	100-120 VAC 60 Hz (North America) 200-240 VAC 50/60 Hz (International)	Connection type: Hardwired in unit
	Phase	1	
	Maximum Current	0.9A	

Table 2-16 System Power Demand

System Equipment	Power Draw (kVA) through MDP			
	Type A	Type B	Type C	Type D, E
SC PDU Continuous Power	25	25	25	25
SC PDU 50 Millisecond Power	29.3	29.3	29.3	29.3
11 kW Chiller Continuous Power	10.9 x 2	-	10.9	-
Cryocooler Compressor Continuous Power	9	9	9	9
Water Chiller for BRM Continuous Power	-	-	-	4.6
Total system Continuous Power	55.8	34	44.9	38.6
Total System 50 Millisecond Power	60.1	38.3	49.2	42.9

Table 2-17 Required Current per Input voltage setting

Input Voltage (V) (+/-10%)	Total Current (A)				
	Type A	Type B	Type C	Type D	Type E
480	60.1	40.9	50.5	47.6	47.6
415	66.8	47.3	57	55.1	55.1
400	69.3	49.1	59.2	57.2	57.2
380	72.9	51.7	62.3	60.2	60.2
208	N/A	94.4	N/A	114	114
200	N/A	98.1	N/A	117.7	117.7

Notes:

- Each site should be planned according to input voltage and system configuration type.
- Local chiller or facility water power needs not included in Type B configuration.
- Step Down Transformer option (M3335TZ) could be used in Type D or Type E, in calculation 98% transforming efficiency is considered with Air cooled compressor, and 90% transforming efficiency is considered with BRM chiller.
- Conductor size selection should be follow system current and local electrical code.

2.10.2 GE HealthCare Supplied Main Disconnect Panel (MDP) Specifications for M50022MB and M50022MC

The customer is responsible for determining the suitability of the GE HealthCare supplied MDP with respect to governing electrical codes.

The GE HealthCare MDP consists of the following:

- A 3-pole main circuit breaker rated for the total current of all the sub-breaker circuits.
- A 3-pole circuit breaker rated for the current of the PDU circuit.
- A 3-pole circuit breaker rated for the current of the 11kW Chiller Circuit (Types A and C) or BRM Chiller Circuit (Types D and E).
- A 3-pole circuit breaker rated for the current of the 2nd 11 kW Chiller unit circuit (Type A only).
- A 3-pole circuit breaker rated for the current of the cryocooler compressor circuit.
- All circuit breakers have a short circuit current interrupting rating of 25000 Amps at 480V and Icc rating of 25000 Amps at 415V.
- Auto restart on the Cryocooler compressor and chiller circuit following loss and restoration of power.
- Two remote Emergency Off Buttons to be installed external to the MDP. Emergency Off removes power from all outputs when activated. MDP supports maximum E-off cable length of 100 meters when remote EPO push buttons are installed in the field.
- Terminal blocks that can accept wire sizes for M50022MB and M50022MC are listed under [2.10.2 GE HealthCare Supplied Main Disconnect Panel \(MDP\) Specifications for M50022MB and M50022MC on page 64](#)
- Provision for terminating facility incoming neutral wire on the neutral terminal block.
- Multiple ground terminal blocks as required by panel design.

- GE HealthCare MDP M50022MC is listed and labeled by Nationally Recognized Testing Lab (NRTL) in accordance with UL 508A and bears UL and CE mark. This MDP is certified as per UL 508A and IEC 61439-2 standards.
- GE HealthCare MDP M50022MB bears manufacturer's CE marking in accordance with the EU Low Voltage Directive 2014/35/EU and Electromagnetic Compatibility Directive 2014/30/EU and is certified as per IEC 61439-2 standards.
- Power on indicator for main breaker output power.
- Two isolated, normally open contact pairs that open when e-OFF is pressed or facility power is interrupted for use with optional accessories.
- Capability for single point lock-out/tag-out for the entire system (Mains Disconnect / Input Breaker) and a means to lock-out/tag-out each output breaker independently. All LOTO points support a standard sized hasp for lock-out.

Figure 2-30 GE HealthCare supplied Main Disconnect Panel (MDP) Setup for Type A configuration (M50022MB and M50022MC)

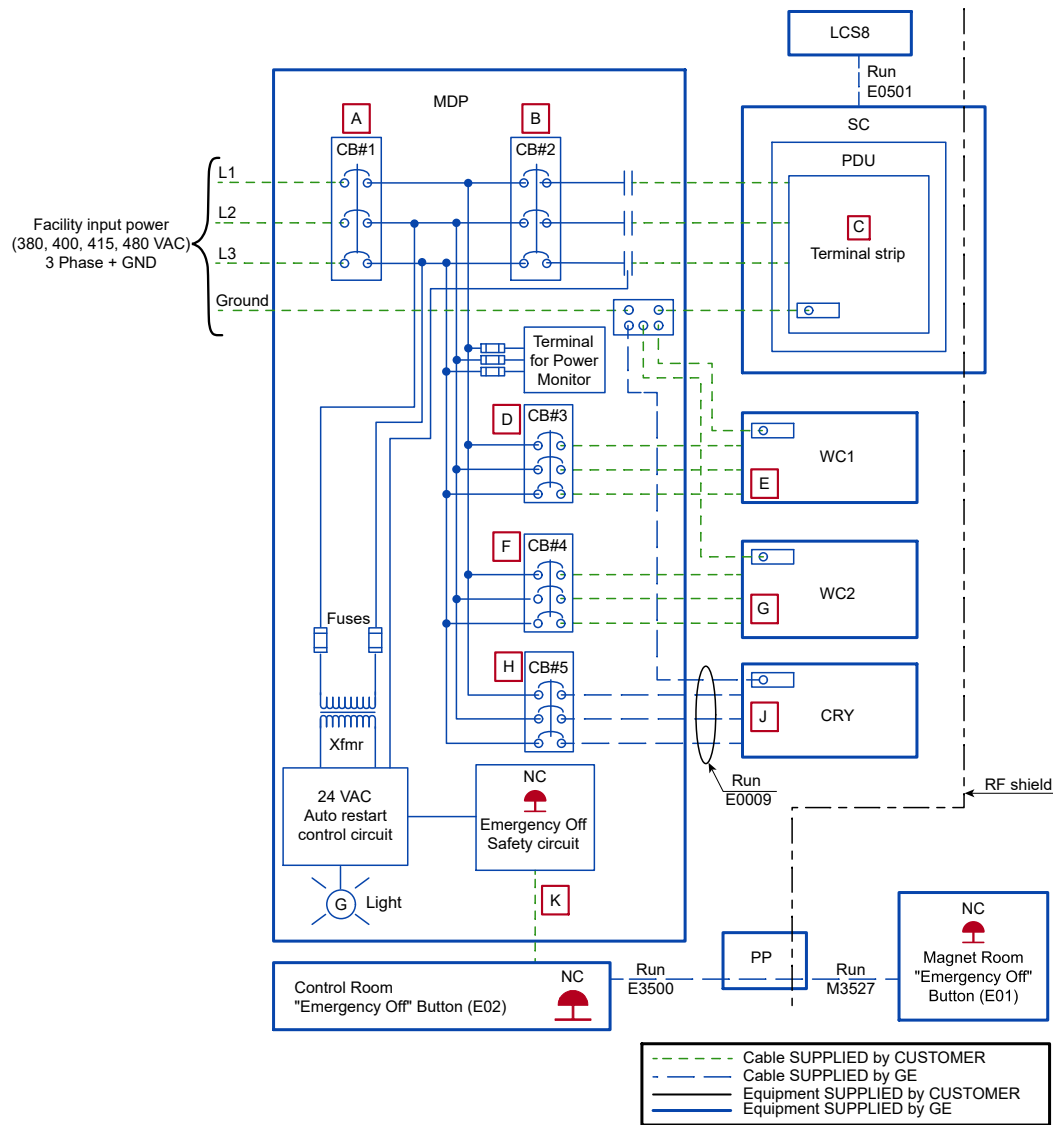

Figure 2-31 GE HealthCare supplied Main Disconnect Panel (MDP) Setup for Type B configuration (M5002MB and M5002MC)

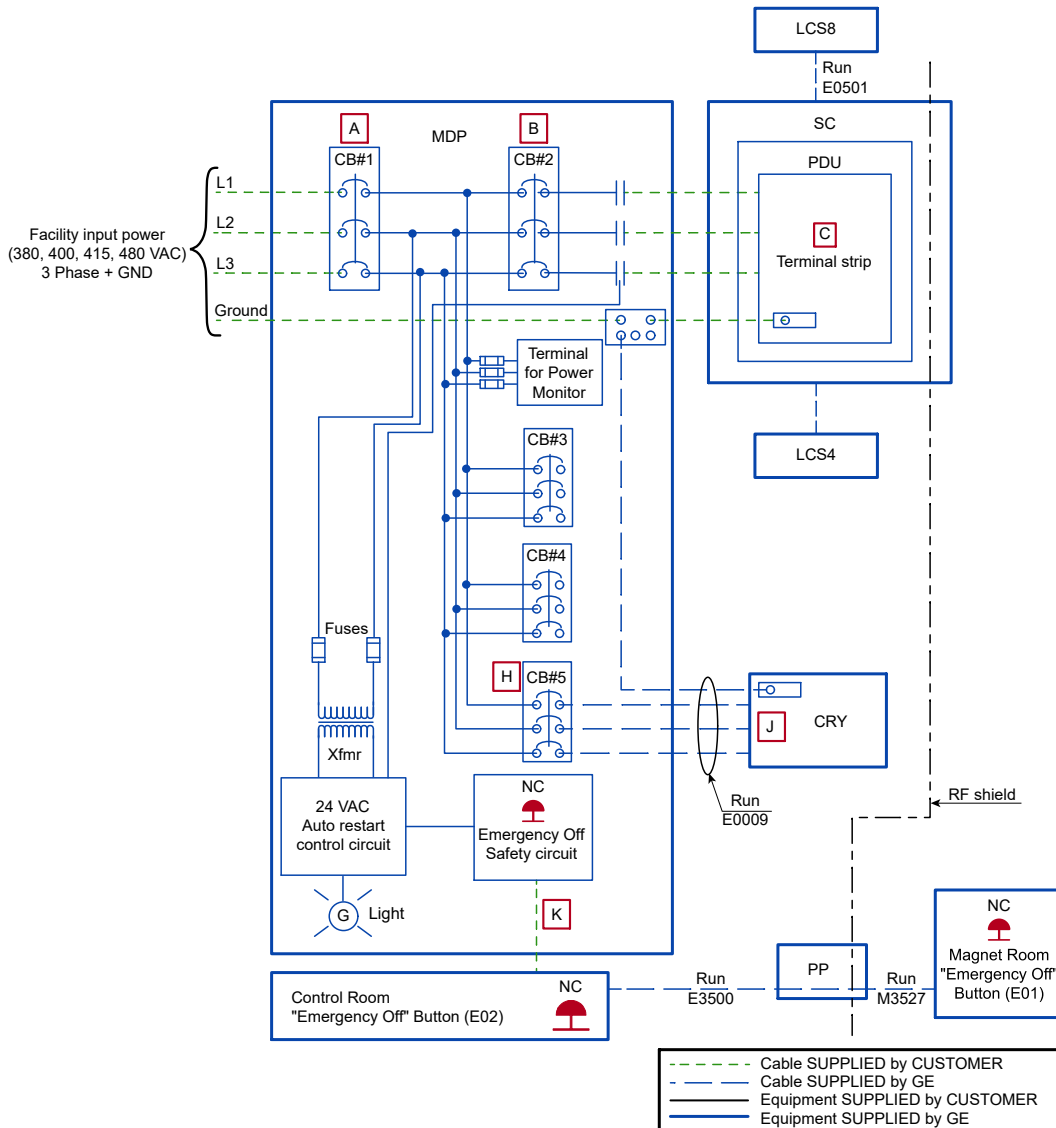

Figure 2-32 GE HealthCare supplied Main Disconnect Panel (MDP) Setup for Type C configuration (M50022MB and M50022MC)

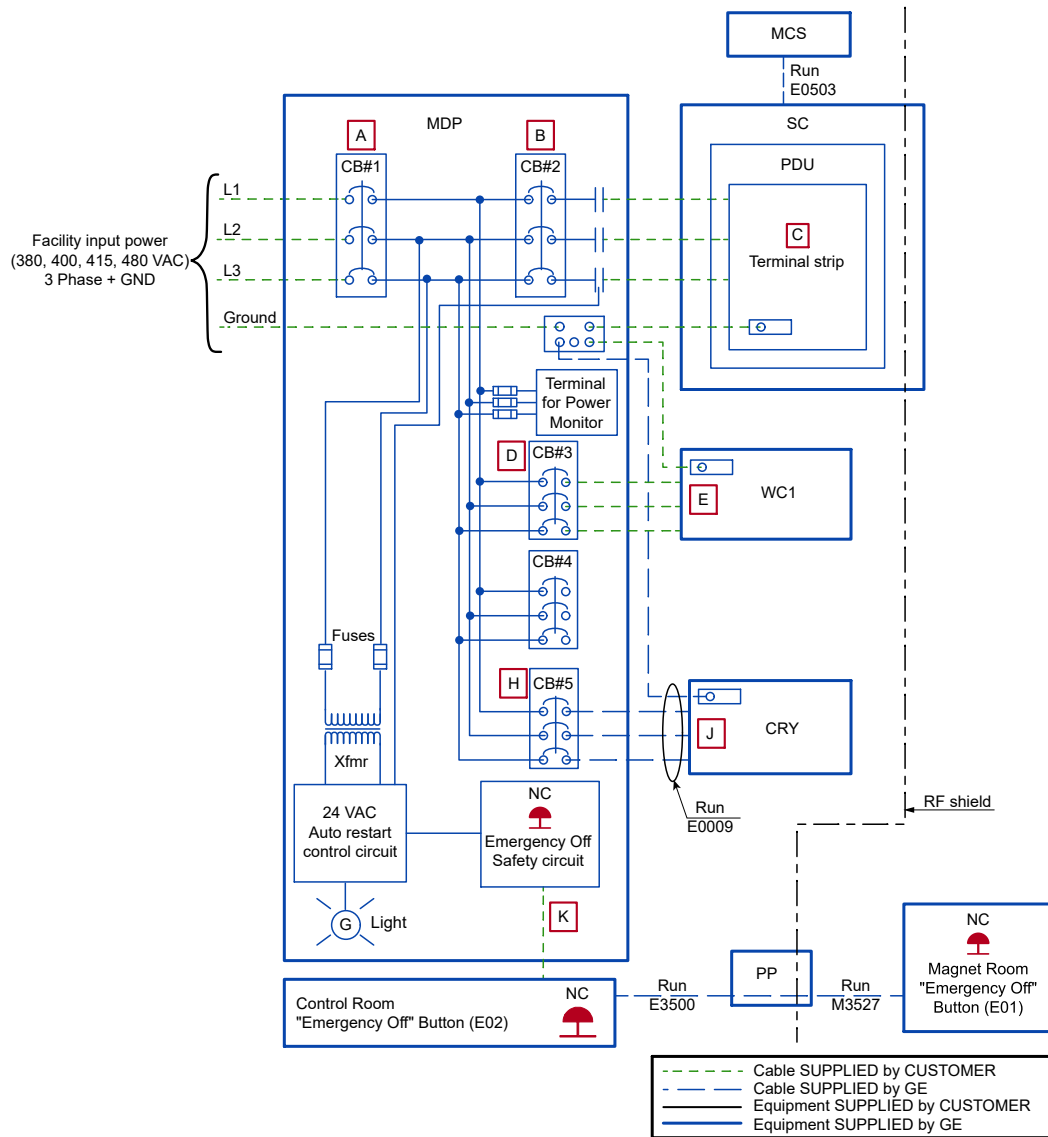

Figure 2-33 GE HealthCare supplied Main Disconnect Panel (MDP) Setup for Type D configuration (M50022MB and M50022MC)

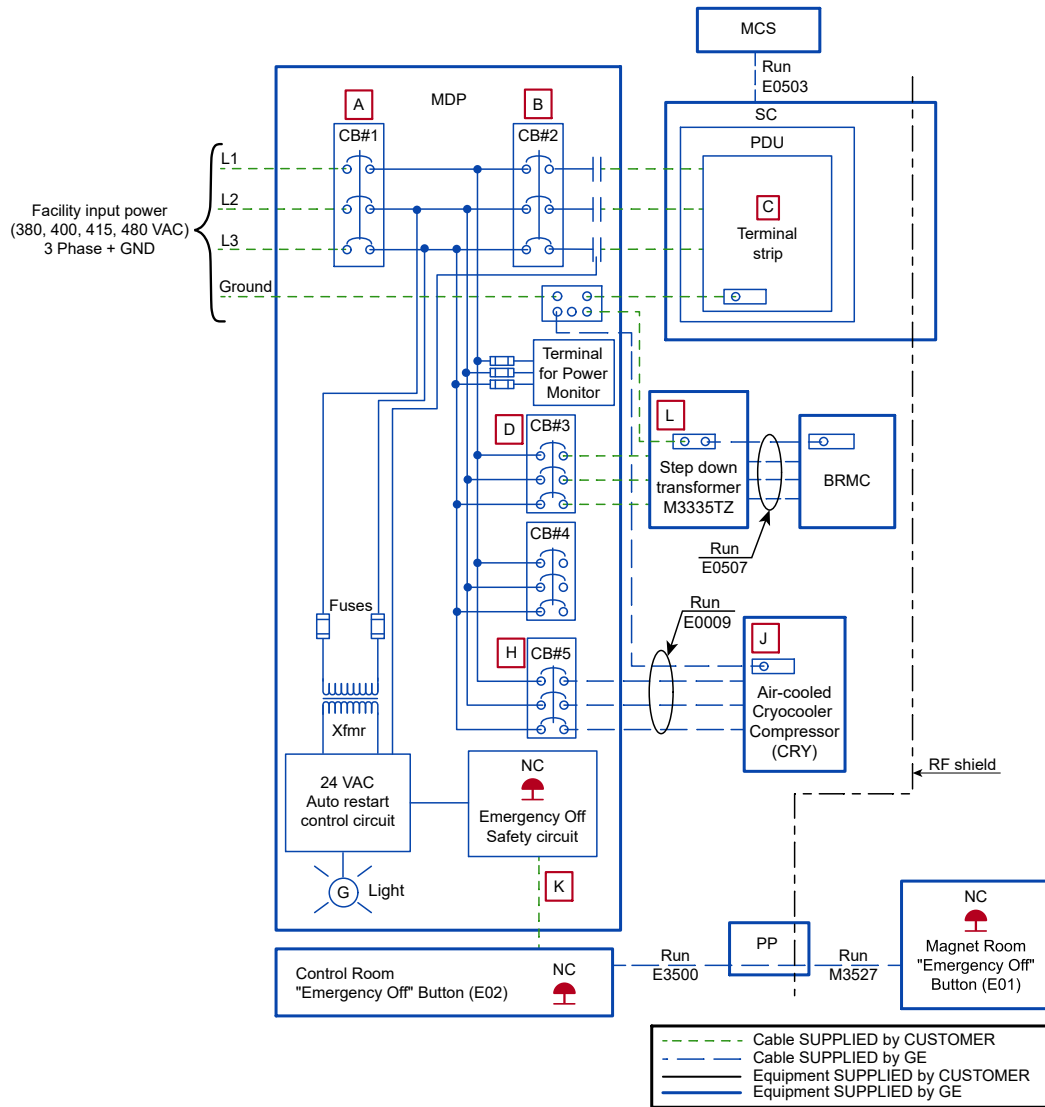

Figure 2-34 GE HealthCare supplied Main Disconnect Panel (MDP) Setup for Type E configuration (M50022MB and M50022MC)

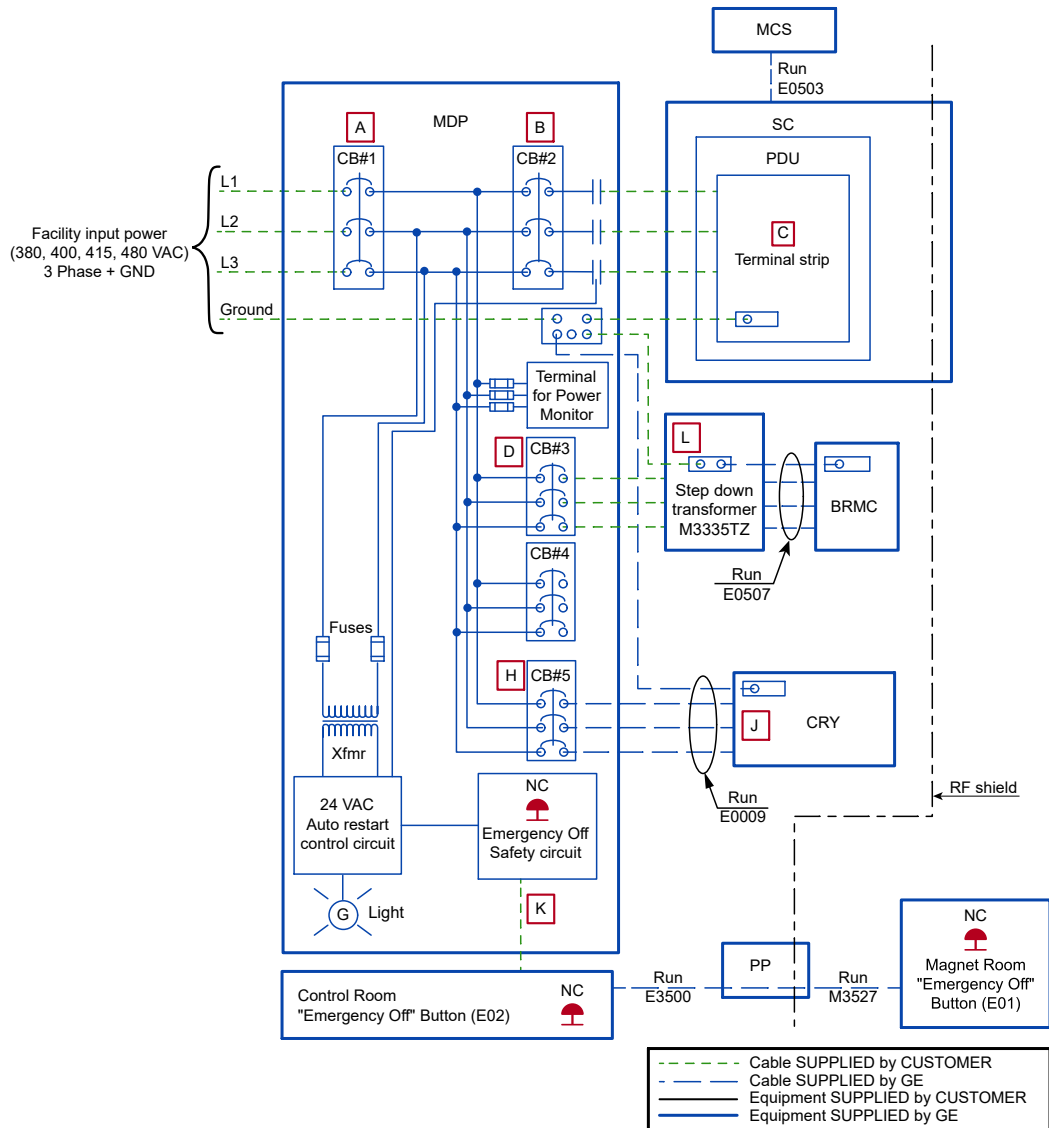

Table 2-18 GE HealthCare Supplied MDP Breaker Sizes

Circuit Breaker	Breaker Size
CB1	100A
CB2	60A
CB3	25A
CB4	25A
CB5	25A

Table 2-19 GE HealthCare Supplied MDP - Range of Standard Conductors Accepted for M50022MB and M50022MC

Item	Phase		Ground	
	sq mm	AWG/kcmil	sq mm	AWG/kcmil
A	6-70	10-2/0	16-120	6-250
B	6-35	10-2	16-120	6-4/0
C	6-35	10-1	6-35	10-1
D	2.5-50	14-1/0	2.5-25	14-4
E/G	4-6	12-10	4-6	12-10
F/H	2.5-50	14-1/0	2.5-25	14-4
L	4-10	12-8	4-10	12-8
J	2.5-6	14-10	2.5-6	14-10
K	0.5-2.5	22-12	N/A	N/A

2.10.3 Customer-supplied Main Disconnect Panel (MDP) Requirements (exempt countries only*)

**NOTE**

* The requirements listed below apply only to exempt countries. Please contact your GE HealthCare Project Manager of Installation (PMI) for the list of exempt countries.

WARNING**PERSONNEL INJURY OR EQUIPMENT DAMAGE**

Customer supplied MDP must have correctly sized wires and rated components to meet the MR System Power Requirements.

**NOTE**

Refer to [8.5 Sample control schematic for customer-supplied MDP on page 166](#).

1. MDP shall provide Auto-Restart to the Cryocooler Compressor and chillers.
2. Manual Restart Capability
 - 2.1. The MDP shall disconnect the PDU circuits upon power loss.
 - 2.2. The MDP shall require a manual restart on the PDU circuits when power is reapplied after an outage.
3. Emergency Off Circuit
 - 3.1. The MDP shall have an emergency off control circuit that disables power to the entire MR System.
 - 3.2. The emergency off circuit shall be actuated by a push button on the panel, and shall also be capable of being actuated by remotely located push button(s).
 - 3.3. Manual reset of the emergency off circuit shall be required to restore power to the entire system.

4. Lock-out/Tag-out:
 - 4.1. The MDP shall provide single point lock-out/tag-out for the entire system and a means to lock-out/tag-out each output breaker independently.
 - 4.2. The lock-out/tag-out feature shall accommodate a standard sized lock hasp.
 - 4.3. The lock-out/tag-out features shall be accessible from the outside of the panel, without the need to open the panel door(s).
5. The MDP shall have a Power ON indicator (Green light) on the panel.
6. The MDP shall meet national/local regulations.
7. The MDP shall provide terminations for all grounds entering, leaving and residing within the panel.
8. The MDP shall provide terminations of appropriate size for all power wiring entering and leaving the panel. Refer to [Figure 2-35 Customer-supplied MDP Setup for Type A on page 72](#), [Figure 2-36 Customer-supplied MDP Setup for Type B on page 73](#), [Figure 2-37 Customer-supplied MDP Setup for Type C on page 74](#), [Figure 2-38 Customer-supplied MDP Setup for Type D on page 75](#), and [Figure 2-39 Customer-supplied MDP Setup for Type E on page 76](#). All wire types, color, and sizing are to be selected in accordance with governing electrical codes.

Figure 2-35 Customer-supplied MDP Setup for Type A

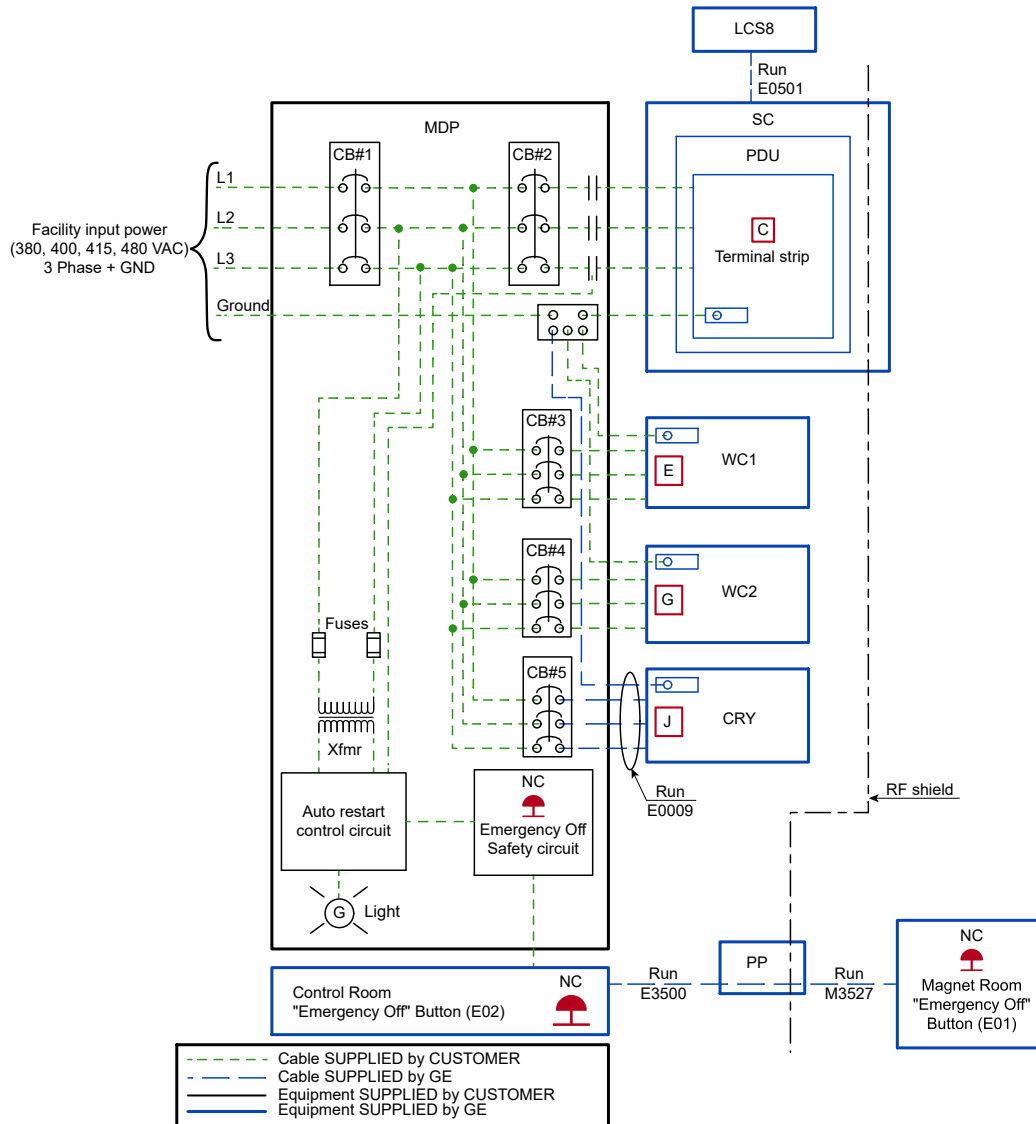

Figure 2-36 Customer-supplied MDP Setup for Type B

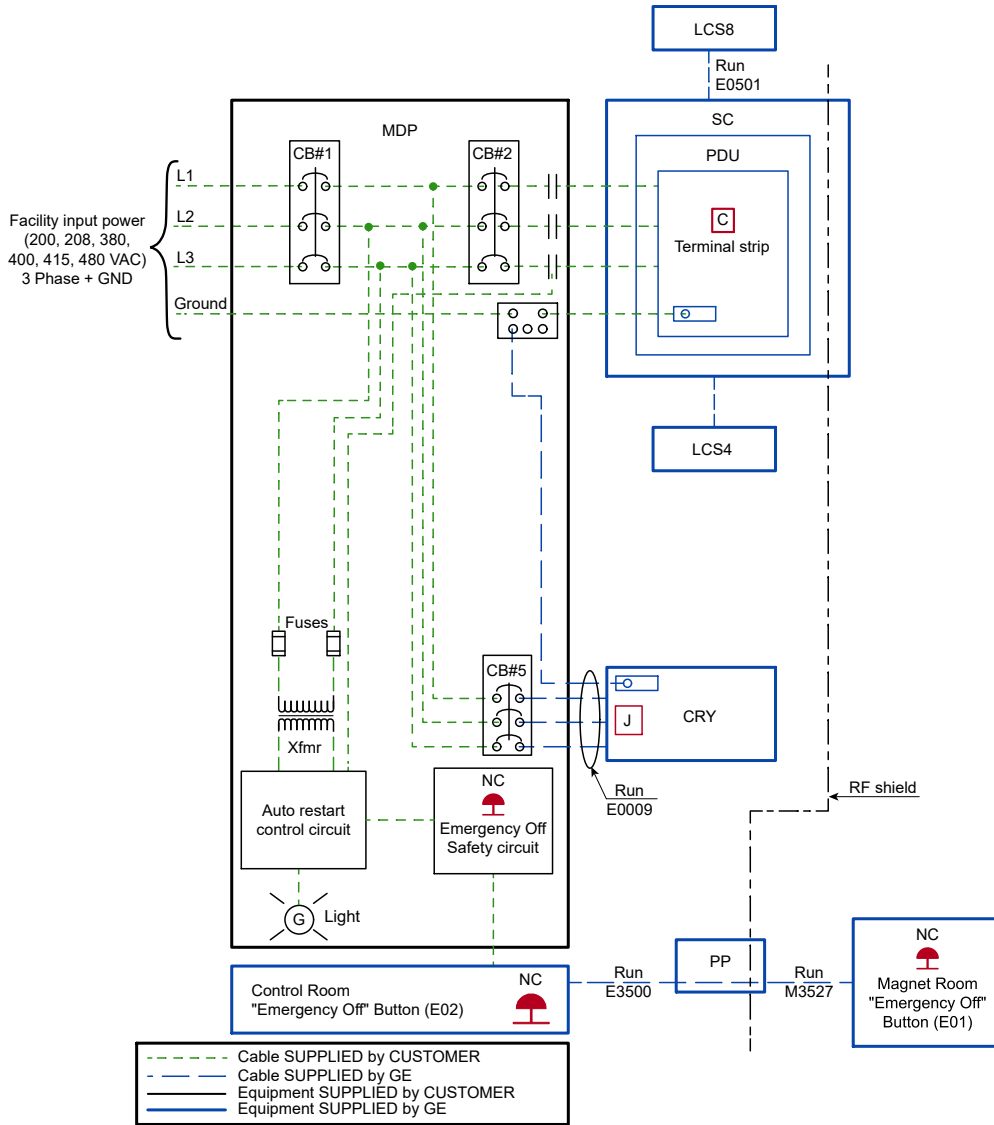

Figure 2-37 Customer-supplied MDP Setup for Type C

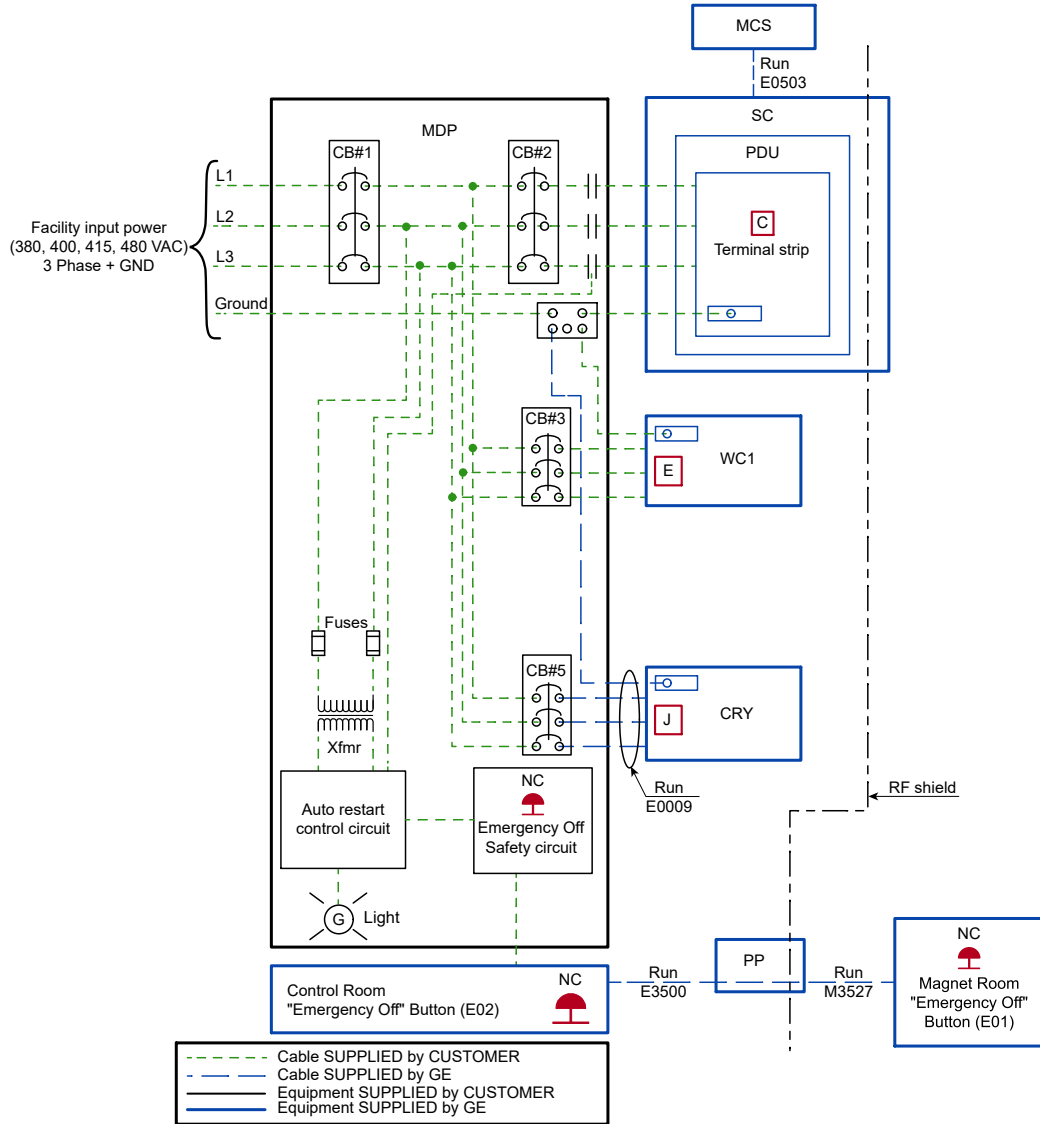

Figure 2-38 Customer-supplied MDP Setup for Type D

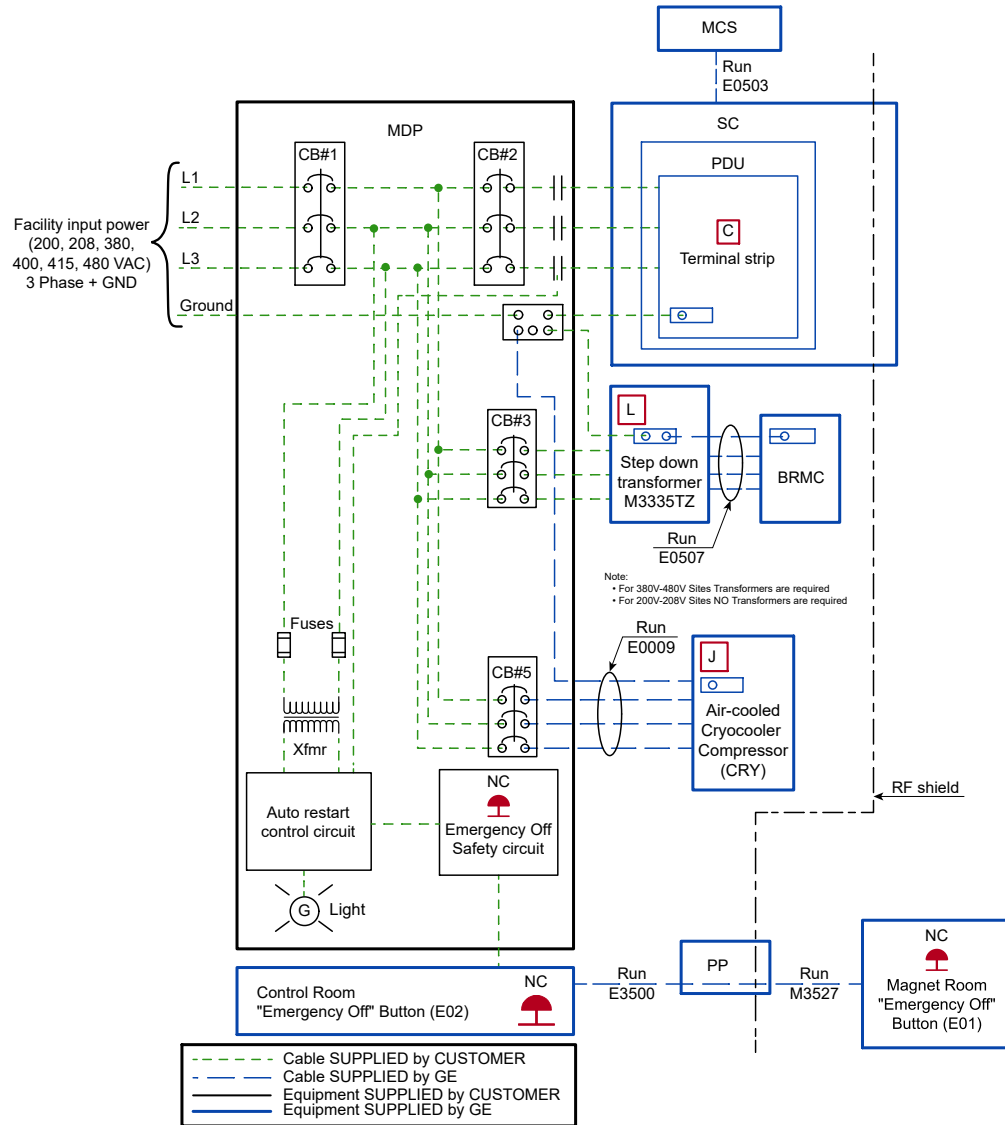

Figure 2-39 Customer-supplied MDP Setup for Type E

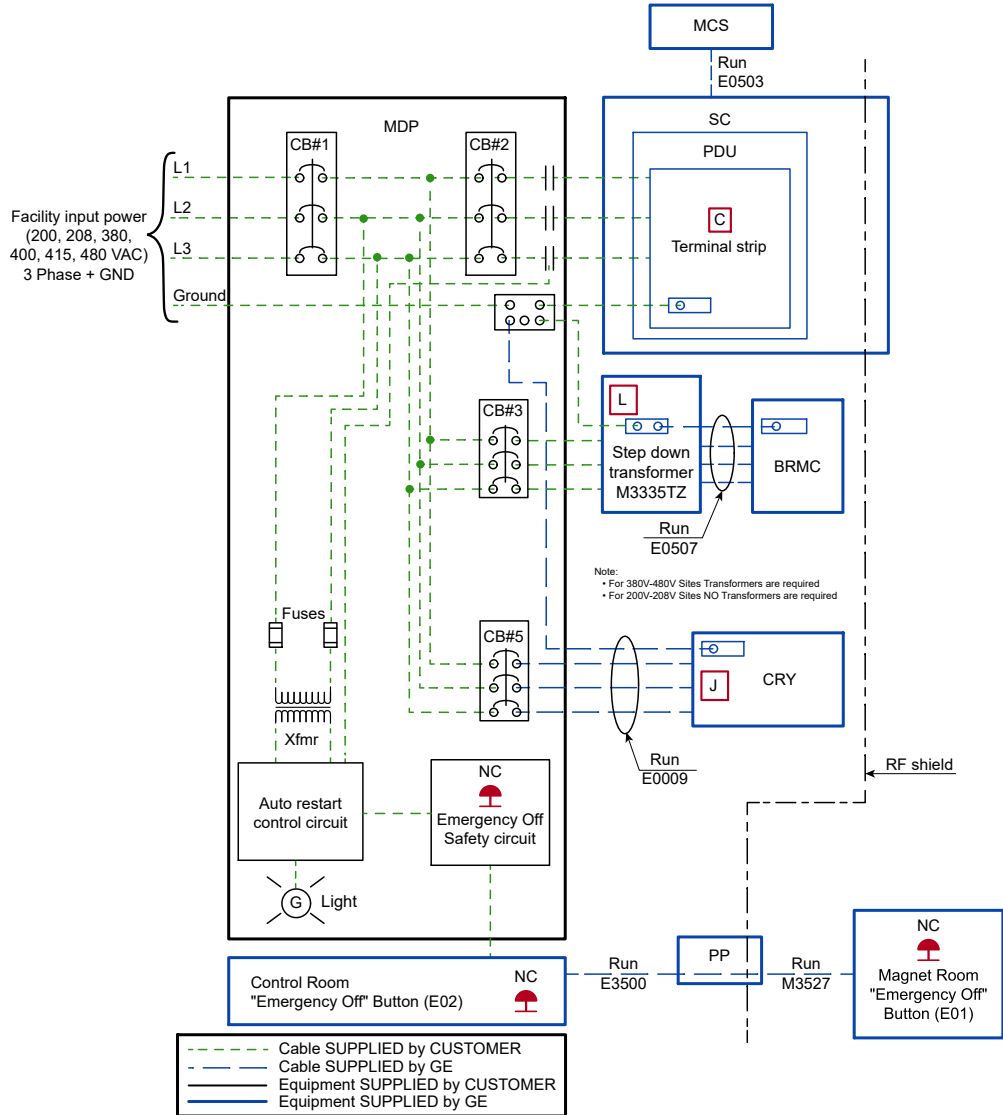

Table 2-20 Customer Supplied MDP - Required Breaker Size

Circuit Breaker	Breaker Size
CB1	150A
CB2	100A
CB3	20A
CB4	20A
CB5	25A

Table 2-21 Customer Supplied MDP - Range of Standard Conductors Accepted

Item	Phase		Ground	
	sq mm	AWG/kcmil	sq mm	AWG/kcmil
C	6-35	10-1	6-35	10-1

Table 2-21 Customer Supplied MDP - Range of Standard Conductors Accepted (Table continued)

Item	Phase		Ground	
	sq mm	AWG/kcmil	sq mm	AWG/kcmil
E/G	4-6	12-10	4-6	12-10
J	2.5-6	14-10	2.5-6	14-10
L	4-10	12-8	4-10	12-8

2.10.4 Emergency Power Backup Specifications (Optional)

The following facility backup power is recommended for continuous operation of the cryocooler compressor and Magnet Monitor:



NOTE

If the compressor must operate on emergency backup power, it still requires chilled water defined in the [2.9.9 Cryocooler Compressor Temporary Backup Water Requirement - Type B, C, E](#) on page 57.

- Dedicated, single power supply to the compressor
- Magnet Monitor emergency power (110V / 220V, 3A). Refer to [Magnet Monitor \(MON\) Requirements and Specifications](#) on page 132.
- Emergency Off Circuit (E-Off) for the emergency backup to the compressor. LOTO is required for the power source between the generator and compressor.
- A transfer switch to remove the primary power source from the compressor when in emergency backup power mode.

Table 2-22 Specifications for Emergency Power to Cryocooler Compressor

	F-50SH/FA-50SH	F-50L/FA-50SL
Power Line Voltage  WARNING Do not use an inverter for the main power source.	AC 380, 400, 415V / 50 Hz, 3 phase (3 Wire + Ground) AC 460, 480V / 60 Hz, 3 phase (3 Wire + Ground) Commercial Power Source	AC 200V / 50, 60 Hz, 3 phase (3 Wire + Ground) Commercial Power Source
Operating Current	Max. 13A (Both 50 and 60 Hz)	Max. 23/26A (50/60 Hz)
Starting current	75/80A (50/60 Hz)	150/160A (50/60 Hz)
Minimum Circuit Ampacity	17A	32A
Maximum Fuse or Circuit Breaker Size	30A	50A
Power Requirement	Minimum 9 kVA Note: The manufacturer recommends a connection capable of 12 kVA.	Minimum 9 kVA
Power Consumption	Max. 8.3 kW / Steady State 7.5 kW at 60 Hz Max. 7.2 kW / Steady State 6.5 kW at 50 Hz	

2.11 MR System Shipping and Receiving



(Applies to all subsections within this section)



IMPORTANT

All shipping dimensions and weights are approximate and may vary based on ship-to location, required rigging, or other requirements. Some shipping or access routes may have requirements in addition to those listed in this section. Contact the GE HealthCare Project Manager of Installation (PMI) to verify magnet shipping, rigging, and access.

2.11.1 Receiving Requirements

1. The customer must provide an area for unloading system components from the truck and delivering to the MR suite



NOTE

Contact GE HealthCare project manager for magnet handling document to be used by rigging companies.

2. The customer is responsible for ensuring:
 - 2.1. All floors along the route will support the weight of the magnet (GE HealthCare recommends a structural analysis)
 - 2.2. Doors or other openings are sufficiently wide to allow passage
 - 2.3. Sufficient room is provided for any required rigging tools

2.11.2 Facility Delivery Route Requirements

The following table lists the delivery dimensions of system components. Upon delivery, verify the component dimensions and weight. The delivery route must be planned to accommodate the dimensions listed.

Table 2-23 Delivery Route Requirements

Component	Width		Height		Depth		Weight	
	mm	in.	mm	in.	mm	in.	kg	lb.
SC	1100	43.3	2032	80	970	38.2	956	2108
Cryogen	Dimensions vary depending on dewar type used. Verify with cryogen supplier.							
Magnet	See 2.11.3 MR System Component Shipping Specifications on page 79 .							

Figure 2-40 RD Series Magnet Minimum Delivery Route Dimensions (90° Turn)

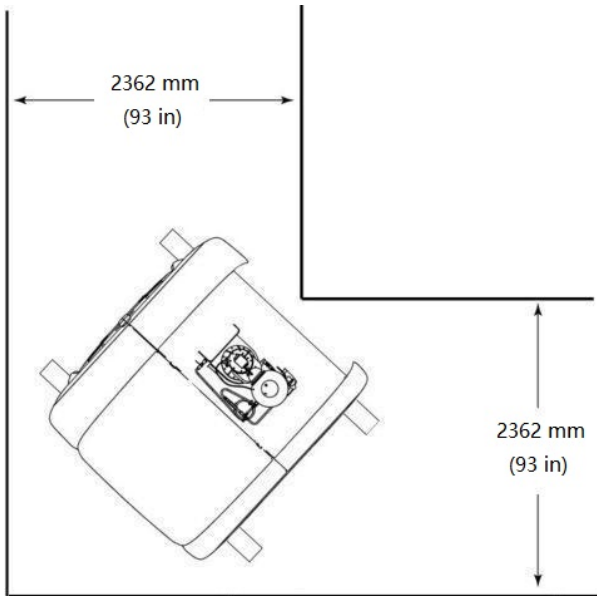

2.11.3 MR System Component Shipping Specifications

MR System component shipping dimensions and weight are listed below:

Table 2-24 MR System Components Shipping Specifications

Component	W x D x H		Weight		Notes
	mm	in.	kg	lb.	
Magnet (as shipped with lifting bars)	2362 x 2387.6 x 2326.6	93 x 94 x 91.6	5320	11700	Domestic - Tarp
Magnet (Crated for International Shipping)	2438 x 2899 x 2692	96 x 114 x 106	6318	13900	International - crate/pallet
Magnet Accessory Equipment	1219 x 1219 x 711	48 x 48 x 28	182	400	crate
Water Cooled Compressor	660 x 711 x 1067	26 x 28 x 42	125	275	skid with box cover
Air Cooled Compressor	800 x 660 x 1140	32 x 26 x 45	166	366	crate/pallet
Rear Pedestal Assembly with Rear Split Bridge Assembly, Low Profile Carriage Cover	864 x 1473 x 1219	34 x 58 x 48	132	310	box on pallet
Enclosure Skirts	1016 x 610 x 610	40 x 24 x 24	14	30	box
Water Chiller for BRM (Type D, E)	737 x 1067 x 838	29 x 42 x 33	154	320	crate
4 kW LCS (Type B, B')	500 x 1000 x 750	19.7 x 39.3 x 29.5	33	86	

Table 2-24 MR System Components Shipping Specifications (Table continued)

Component	W x D x H		Weight		Notes
	mm	in.	kg	lb.	
8 kW LCS (Type A, B, B')	500 x 1000 x 750	19.7 x 39.3 x 29.5	49	108	
MCS (Type C, D, E)	700 x 1000 x 850	27.5 x 39.5 x 31.5	100	220	
Low Height Fixed Patient Table	2380 x 680 x 1034	93.7 x 26.8 x 40.7	250	551	pallet
Lite Patient Table	2170 x 685 x 790	85.4 x 27.0 x 31.1	220	485	pallet
System Cabinet	1310 x 1060 x 2300	52 x 42 x 90.5	1016	2240	crate
Operator Work-space Cabinet	550 x 850 x 790	21.7 x 33 x 31	78	172	wood pallet with cardboard cover
Operator Work-space equipment	813 x 813 x 584	32 x 32 x 23	45	100	box
Operator Work-space Table	1041x 1372 x 381	41 x 54 x 15	75	165	box
VibroAcoustic Damping Kit (Optional)	914 x 1651 x 305	36 x 65 x 12	261	575	box on pallet
11 kW Airsys Chiller (Type A, C)	1180 x 860 x 1490	46 x 33.5 x 58	355	782	crate
11 kW Airsys Chiller Accessories	800 x 800 x 920	31.5 x 31.5 x 36	178.5	394	box

Figure 2-41 Magnet Dimensions (as Shipped)

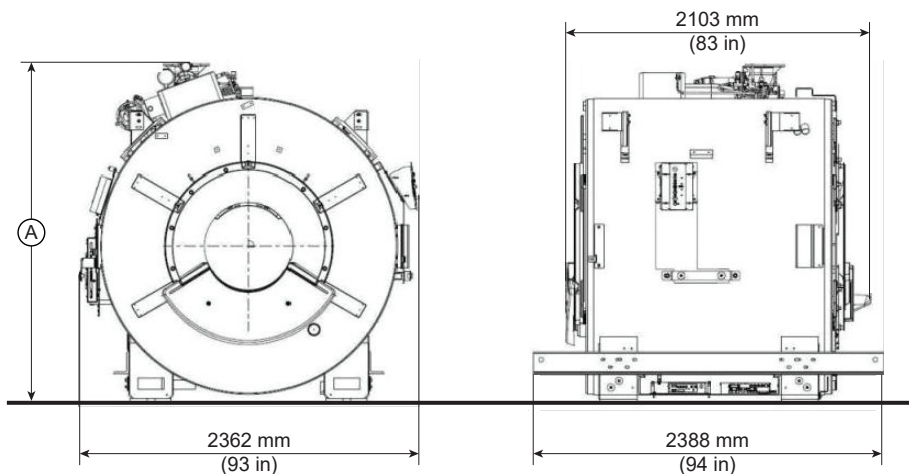

Item	Description
A	Domestic shipment: 2327 mm (91.6 in) International shipment: 2243 mm (88.3 in)

Table 2-25 MR System Component Replacement Shipping Specifications

Component	Component Location	W x D x H		Weight	
		mm	in.	kg	lb.
Replacement RF Body Coil	Magnet Room	762 x 762 x 1524	30 x 30 x 60	70	155
Replacement BRM Gradient Coil Assembly on a Shipping Cradle/Cart	Magnet Room	889 x 2444 x 1420	35 x 96.2 x 55.6	1491	3287
Gradient Amplifier	Equipment room (front of ISC)	910 x 680 x 481	35.8 x 26.8 x 18.9	81	180
Gradient Amplifier Power Supply	Equipment room (front of ISC)	1004 x 483 x 634	39.5 x 19 x 25	154	340
Gradient Coil Replacement Tool Kit Crate	At site near magnet room	787 x 2184 x 952	31 x 86 x 37.5	340	750



NOTE

The dimensions and weights listed for the components in [Table 2-25 MR System Component Replacement Shipping Specifications on page 81](#) include packaging.

Figure 2-42 Gradient Coil Cart

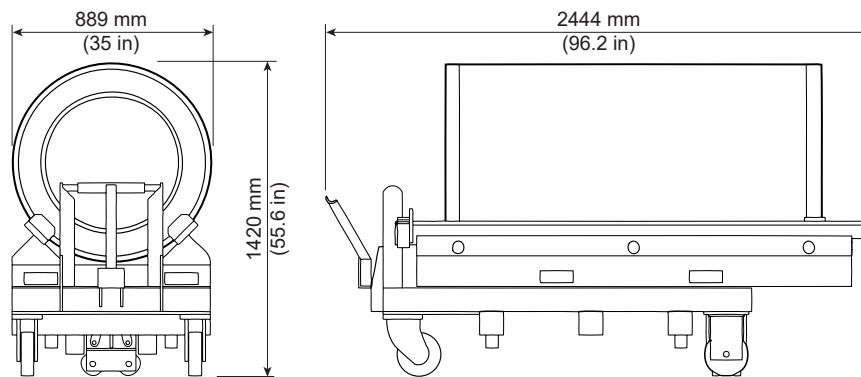

2.11.4 Temperature and Humidity Storage Requirements

MR systems and components must be stored within the environmental requirements listed below.



NOTE

Some equipment is liquid-cooled. After coolant is added, the equipment must be kept from freezing. Phantoms and the coolant itself must also be kept from freezing.

Table 2-26 Transportation and storage environmental conditions for system components

Temperature		Humidity	
Range °C (°F)	Change °C/Hr (°F/Hr)	Relative % (Non-condensing)	Change %/Hr
-34 — 60 (-29 — 140)	20 (68)	10 — 90 10 — 85 (LCD monitor)	30

3 Magnet Room

3.1 Magnet Room Introduction



The Magnet Room is best understood as a series of layers, or “rooms within a room.” Each of these rooms has a specific function and associated requirements. All requirements in this chapter must be followed to ensure safe and correct operation of the MR System.

1. The Magnetic shielded room contains the MR Magnet fringe field within a confined space. A site survey is required to determine magnet shield requirements (not all sites require magnetic shielding). Because of the added cost of magnetic shielding, room location should be carefully considered.
2. The Acoustic room is a layer used to help attenuate the noise produced during a scan. An acoustic engineer is strongly recommended to assess the environment.
3. The RF shielded room is critical to the correct MR System operation. RF shielding prevents interaction of external RF radiation with MR System operation and it also prevents MR System RF radiation from interfering with external systems, such as aircraft control. Special care must be used when installing all fixtures penetrating the RF shield (for example, vents, electrical conduit, penetration panels) to ensure the integrity of the RF shield is maintained. Refer to *RF Shielded Room Requirements*, 5850260-1EN.
4. The Finished room includes the wall coverings, ceiling tile, ceiling grid, other fixtures, Magnet (MAG) and Patient Table (PT). When planning the finished room, ensure the following:
 - 4.1. All building codes are met (such as maintaining egress routes).
 - 4.2. Items which may generate or create RF interference (including fluorescent lighting) are not allowed for installation within the Magnet Room.
 - 4.3. Customer is responsible for the selection and installation of all locally required safety devices (for example, smoke detectors, oxygen monitors, and so on).
 - 4.4. Smoke detectors should be located outside of the Magnet Room (for example, within the return air duct) whenever possible. If code does not allow this, use only simple two wire non-addressable smoke detectors in the Magnet Room.
 - 4.5. Ferrous or metallic items which could become projectiles when the magnet is installed (including wall coverings, ceiling tile, ceiling grid, or other fixtures) are not used or are correctly secured.

Figure 3-1 Magnet Room Layers

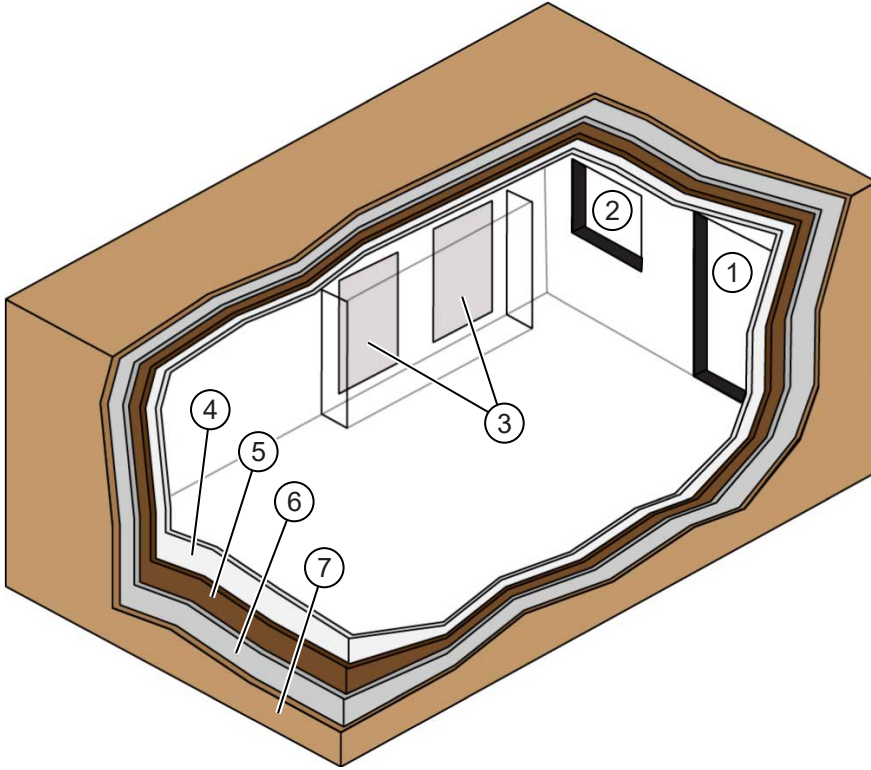

Item	Description	Item	Description
1	Door	2	Window
3	Penetration wall(s)	4	Finished room
5	RF shielding	6	Acoustic barrier
7	Magnetic shielding	-	-



NOTE

The sequence of the room layers can vary based on siting needs.

3.2 Magnet Room Structural Requirements



This section lists the structural requirements that must be considered when performing site evaluation and planning of the Magnet Room.

3.2.1 Overview



1. When preparing a building plan or evaluating a potential site for an MR System, take care to ensure the MR suite will not interact with the surrounding environment (that is, magnetic, acoustic, environmental steel, and vibration).
2. The customer is responsible for vibration testing required to verify suitability of a proposed site. All test results and any questions regarding testing, results, or analysis must be forwarded to the GE HealthCare Project Manager of Installation (PMI).

3.2.2 Environmental Steel Limits



A static magnetic field extends in a three-dimensional space around the magnet isocenter. Environmental steel within the static magnetic field affects the uniformity (or homogeneity) of the field. Field uniformity is critical to both image quality and chemical shift analysis (spectroscopy). An analysis of the environmental steel is required within a 3 m (9.84 ft.) spherical radius of the magnet isocenter. Environmental steel includes pipes, beams, concrete rebar, or any other structural steel in the floors, walls, or ceiling.

The following floor items must be limited per [Table 3-1 Steel Mass Limits to Magnet Isocenter \(3 x 3 m \(10 x 10 ft.\) Area Under Magnet\) on page 86](#).

1. Non-movable steel construction material such as rebar and metal decking
2. Existing or proposed RF/magnetic shielding or shim plates
3. [Table 3-1 Steel Mass Limits to Magnet Isocenter \(3 x 3 m \(10 x 10 ft.\) Area Under Magnet\) on page 86](#) defines the limits of use as a guideline to help the customer understand allowable amounts of ferrous rebar, steel decking, or other components as they design the MR suite and Magnet Room floor structure.
4. The customer must provide detail defining ferrous material below the magnet to the Project Manager so the GE HealthCare MR Siting and Shielding (MRSS) team can review for compliance.

Table 3-1 Steel Mass Limits to Magnet Isocenter (3 x 3 m (10 x 10 ft.) Area Under Magnet)

Limits Of Steel Mass kg/m ² (lb./ft ²)	Distance Below Top Surface Of Floor mm (in.)
0 (0)	0-76 (0-3)
9.8 (2)	76-127 (3-5)
14.7 (3)	127-254 (5-10)
39.2 (8)	254-330 (10-13)
98.0 (20)	330+ (13+)

3.2.3 Vibration Requirements



Excessive vibration can affect MR image quality. Vibration testing must be performed early in the site planning process to ensure vibration is minimized. Both steady state vibration (exhaust fans, air conditioners, pumps, and so on) and transient vibrations (traffic, pedestrians, door slamming, and so on) must be assessed (see [Figure 3-2 Magnet Steady State Vibration Specifications on page 87](#)). Specific requirements for vibration mitigation, include:

1. The Magnet (MAG) cannot be directly isolated from vibration. Any vibration issue must be resolved at the source.
2. MR Suite HVAC must have vibration isolation.
3. A vibration analysis must be performed at the proposed site with the results (and any mitigation) forwarded to the GE HealthCare Project Manager of Installation (PMI). See the [8.2 MR Site Vibration Test Guidelines on page 158](#).
4. A transient vibration test must only be performed after a steady-state test has been performed and all steady-state sources of vibration have been mitigated.
5. Transient vibration levels above the specified limits in the [8.2 MR Site Vibration Test Guidelines on page 158](#) must be given to the PMI for review.
6. Any transient vibration that causes vibration to exceed the steady-state level must be mitigated.
7. The vibration test consultant must account for non-mechanically induced signals such as test equipment instabilities, thermal drift or RF interference.

Figure 3-2 Magnet Steady State Vibration Specifications

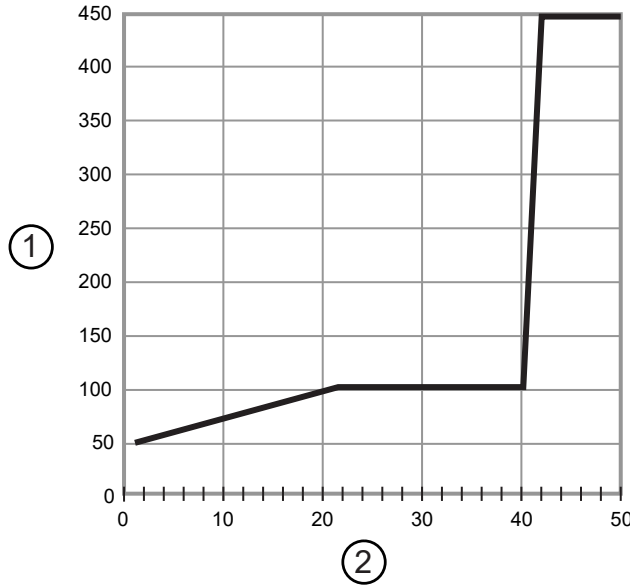

Item	Description
1	Acceleration (g x 10 ⁻⁶) (RMS) above ambient baseline
2	Excitation frequency (Hz)

3.3 Magnetic Shielded Room Requirements



Magnetic shielding prevents interaction between the magnet and nearby sensitive devices. Because of the added cost of magnetic shielding, room location should be carefully considered. All sites, including upgrade sites, must be evaluated for magnetic shielding requirements. Existing magnetic shielding at an upgrade site may not be sufficient for the new system. Contact the GE HealthCare Project Manager of Installation (PMI) to request a site evaluation.

See [MR Suite Magnetic Field Specifications on page 28](#) for detailed magnetic proximity limit information.

1. The GE HealthCare Project Manager of Installation (PMI) works with the customer to coordinate the magnetic shielding site evaluation.
2. The customer is responsible for installation of all magnetic shielding.
3. If rear wall magnetic shield or steel RF wall is closer than 2500mm (98.4 in.) from isocenter, it should be verified by GE HealthCare PMI.

3.4 System Cabinet (SC) and Penetration Panel (PP) Wall Opening Requirements

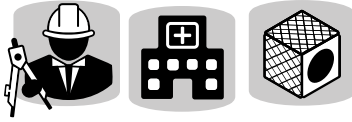

The Penetration Panel must be covered on both sides and SC must be covered on the magnet room side for safety. If GE-supplied adjustable covers are not used, the customer must furnish covers or enclosures with key or tool required for opening to limit access to the panel. The mounting and clearance dimensions for the Penetration Panel and the SC are shown in this section.

[Figure 3-3 Wall Opening Detail for SC \(Equipment or Operator Room Side\) on page 89](#) shows wall cutoff detail for the SC (Equipment or Operator Room side).

Figure 3-3 Wall Opening Detail for SC (Equipment or Operator Room Side)

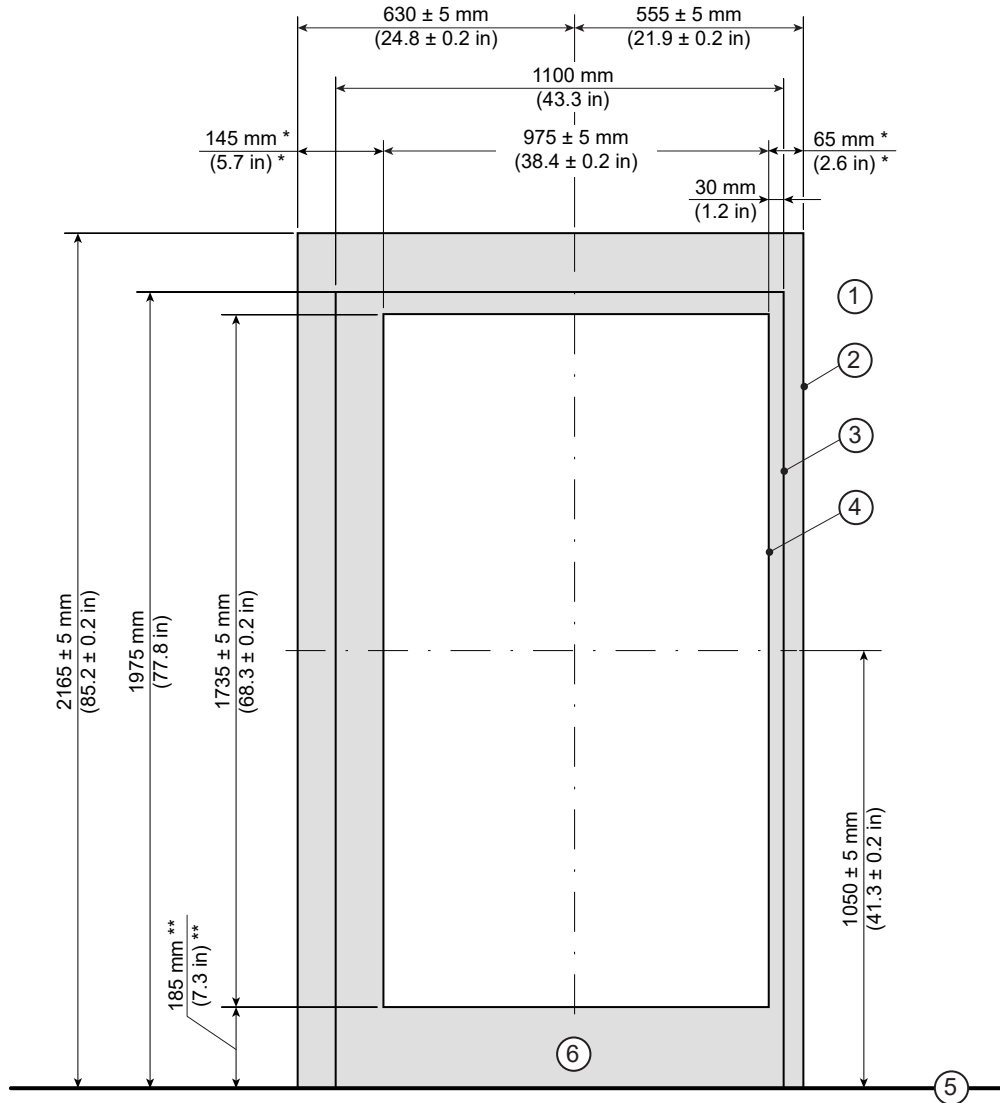

Item	Description	Item	Description
1	Finished Wall	4	Wall Cut Out
2	Finished Wall Cut Out	5	Equipment Room Finished Floor
3	SC Cover Outline	6	Exposed area of RF Shield (Gray Color Area)



NOTE

* This value is the length when the wall cutoff width is 975 mm (38.4 in.).

** This value is the length when the wall cutoff height is 1730 mm (68.11 in.).

Cabinet left side has cooling plumbing assembly. Wall cut out area is not symmetric with cabinet center.

Figure 3-4 RF Shield

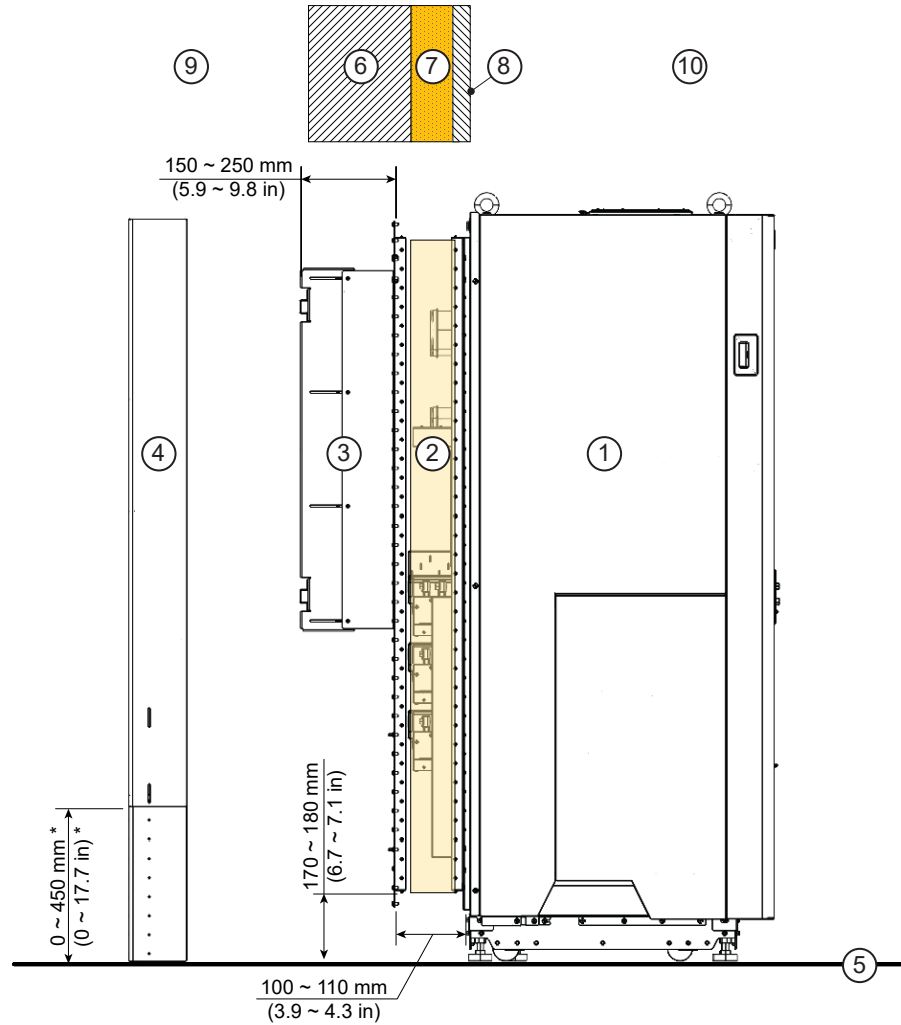

Item	Description	Item	Description
1	SC	6	Magnet Room Finished Wall
2	Mesh Shield	7	RF Shield Wall
3	SC Back Cover Support	8	Equipment Room Finished Wall
4	SC Back Cover	9	Magnet Room
5	Equipment Room Finished Floor	10	Equipment Room



NOTE

* Cables exit the enclosure in this area. Cover height is adjustable. Dimension is referenced from the equipment room finished floor.



NOTE

The single-point ground bar is prepared by the customer. Locate it according to the *Grounding Requirements in RF Shielded Room Requirements, 5850260*.

Figure 3-5 Wall Opening Detail for SC (Magnet Room Side) on page 91 shows wall cutoff detail for the SC (Magnet Room Side).

Figure 3-5 Wall Opening Detail for SC (Magnet Room Side)

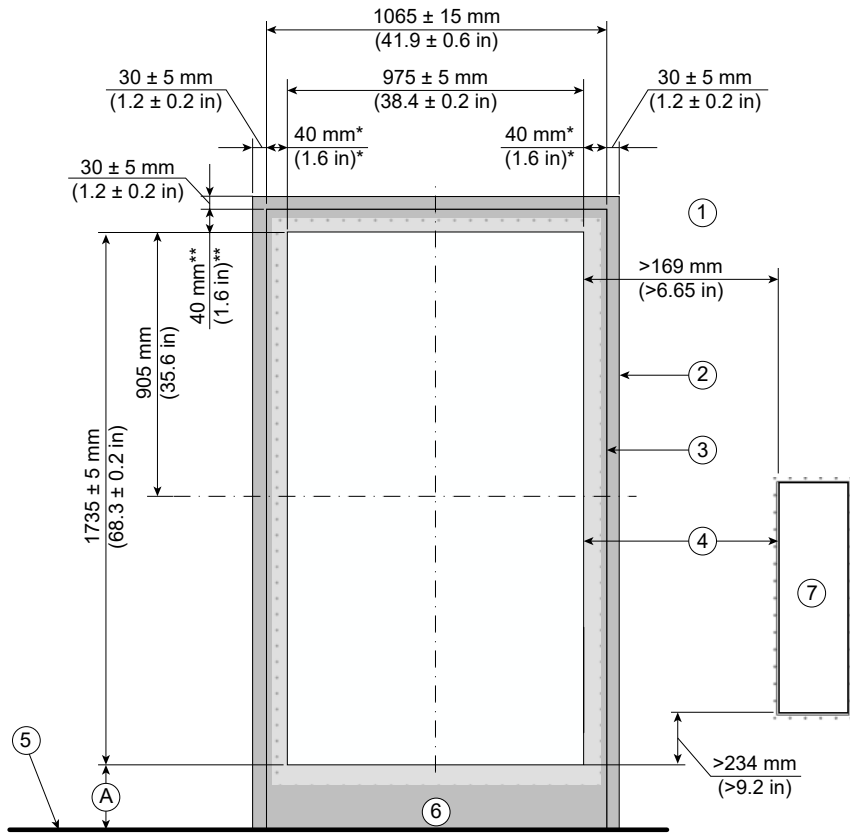

Item	Description	Item	Description
A	The value depends on the height from Equipment Room floor	4	Wall Cut Out
1	Finished Wall	5	Magnet Room Finished Floor
2	Finished Wall Cut Out	6	Exposed area of RF Shield (Gray Color Area)
3	SC Cover Outline	7	Penetration Panel (Can be located on the left or on the right side of the ISC)



NOTE

* This value is the length when the wall cutoff width is 970 mm (38.2 in.).

** This value is the length when the wall cutoff height is 1730 mm (68.11 in.).

Figure 3-6 Wall Opening Detail for Penetration Panel (PP) on page 92 shows wall cutoff detail for the Penetration Panel from both room sides.

Figure 3-6 Wall Opening Detail for Penetration Panel (PP)

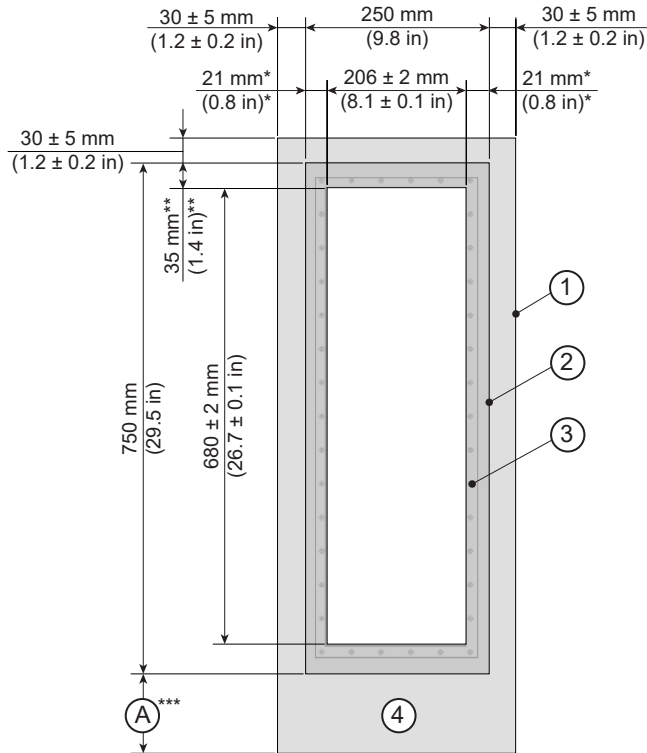

Item	Description	Item	Description
1	Finished Wall Cut Out	3	Wall Cut Out
2	Cover Outline	4	Exposed area of RF Shield



NOTE

- * This value is the length when the wall cutoff width is 208 mm (8.19 in.).
- ** This value is the length when the wall cutoff height is 680 mm (26.77 in.).
- *** Cables exit the enclosure in this area.

Figure 3-7 Screw Locations for Mesh Shield and Penetration Panel (Magnet Room Side) on page 93 shows the screw locations for the Mesh Shield and Penetration Panel.

Figure 3-7 Screw Locations for Mesh Shield and Penetration Panel (Magnet Room Side)

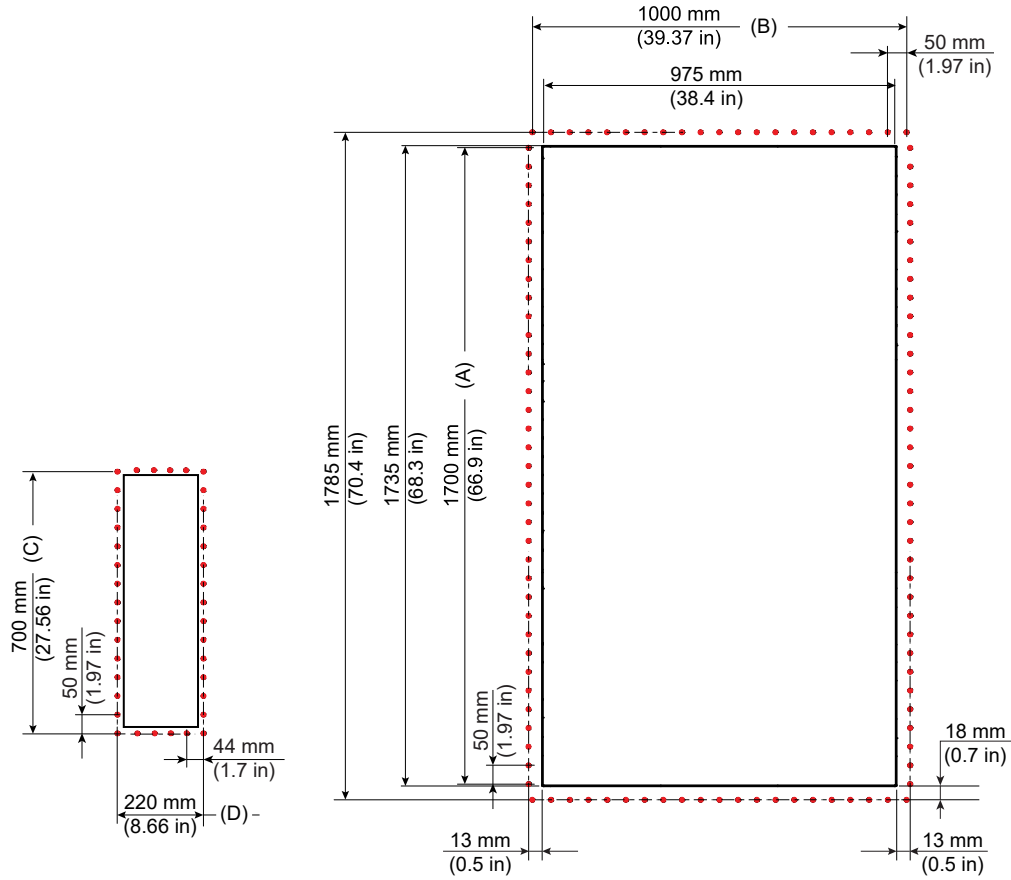

Item	Description	Item	Description
A	35 Screws, Pitch 50 mm (1.97 in.) x 34=1700 mm (66.9 in.)	C	15 Screws, Pitch 50 mm (1.97 in.) x 14=700 mm (27.56 in.)
B	21 Screws, Pitch 50 mm (1.97 in.) x 20=1000 mm (39.37 in.)	D	6 Screws, Pitch 44 mm (1.73 in.) x 5=220 mm (8.66 in.)
Total Screws	2(A+B+C+D) - 4=150 Prepare 170 screws to install the PP and Mesh Shield.		



NOTE

1. M6 screws are used to install the Mesh Shield and PP. The Mesh shield and PP will be installed from the Magnet Room side.
2. It is the RF vendor's responsibility to prepare M6 screws according to the site condition. The Mesh Shield and PP will be installed during the system installation by the mechanical installer.
3. For a wooden RF shield wall: use M6 wood screws.
4. For an RF shield wall that has holes for the screws: use M6 screws and M6 nuts.

Figure 3-8 Duct or Pit Top View

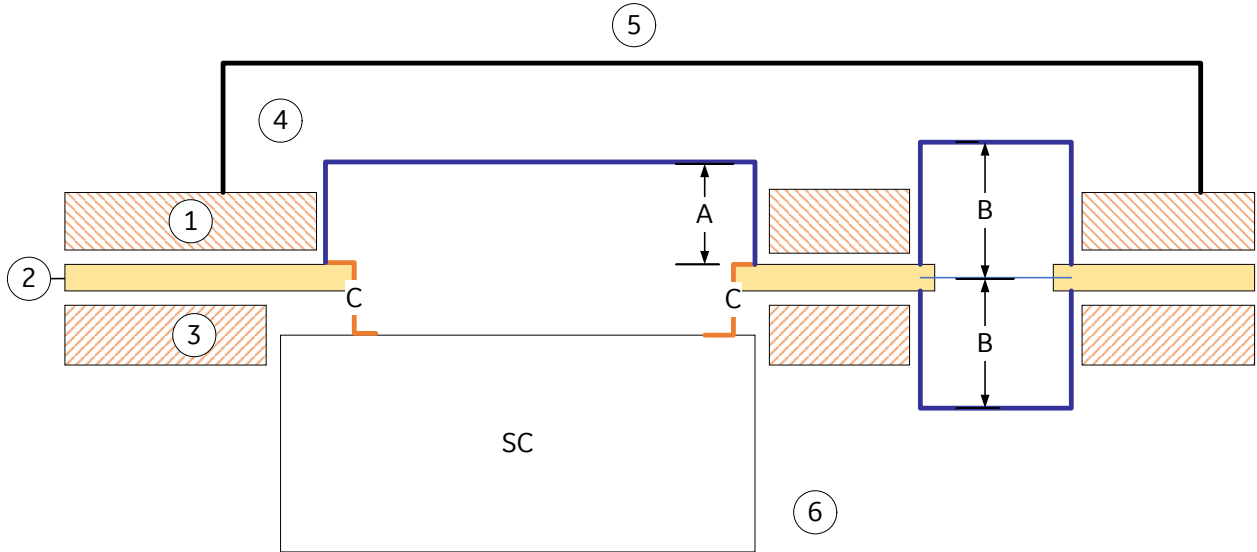

Item	Description	Item	Description
1	Magnet Room Finished Wall	A	The SC back Cover depth is adjustable from 150 mm (5.9 in.) to 250 mm (9.8 in.).
2	RF Shield	B	The Penetration Panel Covers depth is adjustable from 300 mm (11.8 in.) to 400 mm (15.75 in.).
3	Equipment Room Finished Wall	C	The Mesh Shield is adjustable from 100 mm (3.9 in.) to 110 mm (4.3 in.).
4	Duct or Pit Area		
5	Magnet Room		
6	Equipment Room		



NOTE

When cutting the duct or pit for cable routing, make sure the SC Cover can cover the cutoff for the cable.

It is recommended to extend the Mesh Shield in between 100 mm (3.9 in.) and 110 mm (4.3 in.). However, the Mesh Shield can be extended to 180 mm (7.1 in.) without any slack. In case there is any reason that the SC cannot be located closely enough to the RF Shield, it is local site engineer's responsibility to extend the Mesh Shield more than 110 mm (4.3 in.). Consider floor level under the SC when extending the Mesh Shield more than 110 mm (4.3 in.).

3.5 Finished Room Requirements

3.5.1 Ferrous Materials in the Magnet Room



1. Non-ferrous (non-metallic) materials or components should be used in the Magnet Room.
2. Ferrous components or material in the Magnet Room that could be removed for servicing, cleaning, or replacement must be secured to prevent the ferrous material from becoming a projectile (ferrous components or material must also be identified as ferrous to prevent untrained personnel from working on the ferrous material while the magnet is energized).

3.5.2 Walls



Refer to *Acoustic Room Details*, 5850262-1EN. Hard, bare wall surfaces may create a harsh Magnet Room acoustic environment due to reflection of sound waves. Finished walls with acoustic properties can reduce reflected noise.

1. GE HealthCare recommends finished walls to protect the RF shielding.
2. Walls and any millwork, cabinets, storage areas, acoustic coverings, and so on, must remain outside the minimum service area.
3. A metallic electrical conduit inside walls and ceilings may be used. Conduit for receptacles must be metallic.

3.5.3 Magnet Preinstallation Markings



For correct cryogen venting, the magnet vent adaptor must align correctly with the ceiling vent when the magnet is installed.

1. The magnet isocenter position must be clearly marked, and the marking must be identifiable throughout construction.



NOTE

If there is no ceiling grid in the room, we recommend to also mark the magnet isocenter location on the ceiling. This can serve as a reference for positioning a new vent pipe, or can be used to reproduce the floor markings if they become lost during construction.

Refer to *Magnet Room Venting Requirements*, 5850263-1EN for the location of the magnet vent.

- If no ceiling vent pipe exists prior to construction, the location of the magnet isocenter and magnet z-axis orientation must be marked on the Magnet Room floor as shown below.

Figure 3-9 Marking Magnet Isocenter (in a Room Without a Vent Pipe)

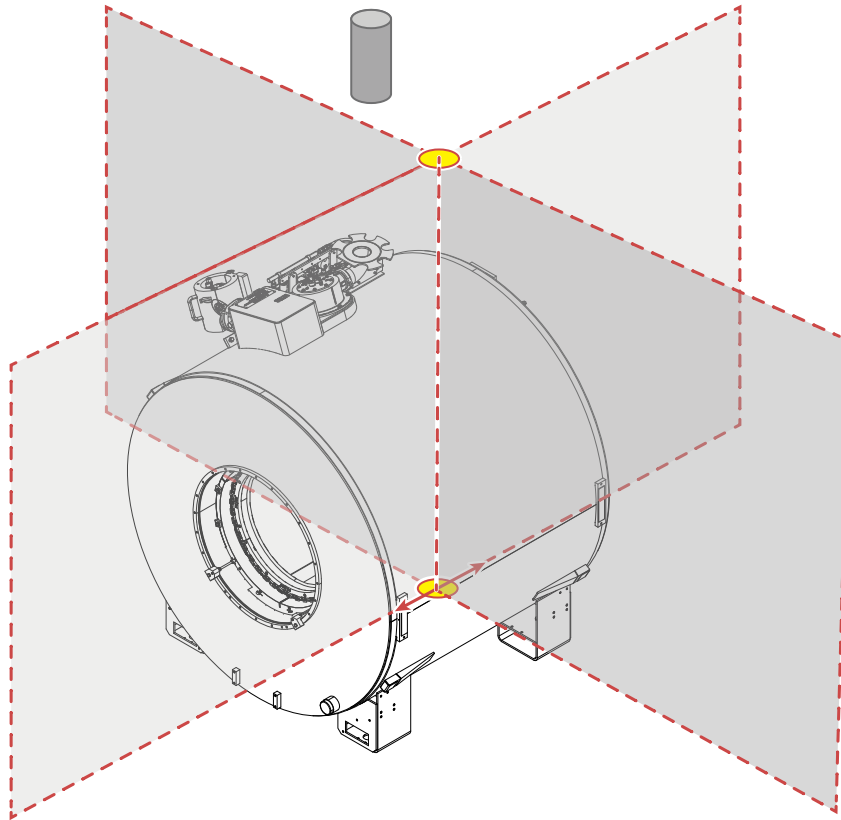
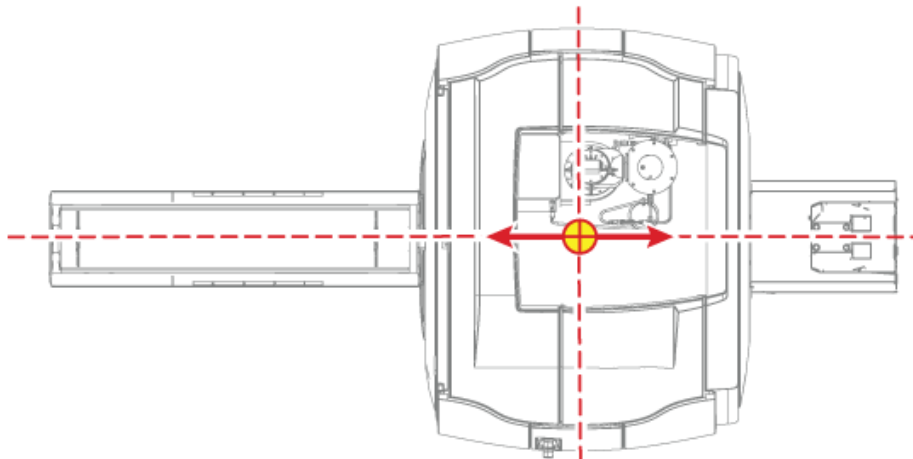

Figure 3-10 Marking the Magnet Isocenter and the Z-Axis Orientation on the Floor



- If a ceiling vent pipe already exists at the start of construction, the magnet isocenter marking must be correctly aligned relative to the position of the vent pipe. Refer to *Magnet Room Venting Requirements*, 5850263-1EN for the location of the magnet vent.

**NOTE**

We recommend:

- Marking the center of the vent pipe.
- Using a cross line laser or other accurate method to transcribe it to the floor directly below.
- Marking the magnet isocenter relative to the vent pipe marking on the floor. The positioning template (5810898-7 or 5810898-8) can be used as a marking aid.

Figure 3-11 Marking the Center of the Vent Pipe

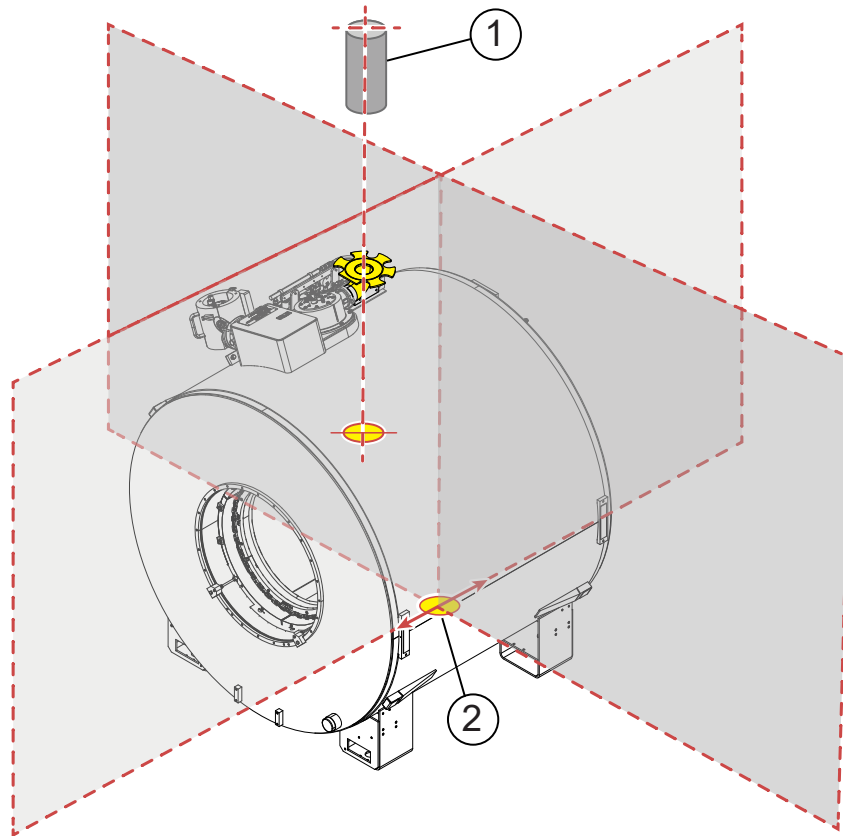

Item	Description
1	Vent center
2	Magnet isocenter

Figure 3-12 Marking the Vent Pipe and Magnet Isocenter on the Floor

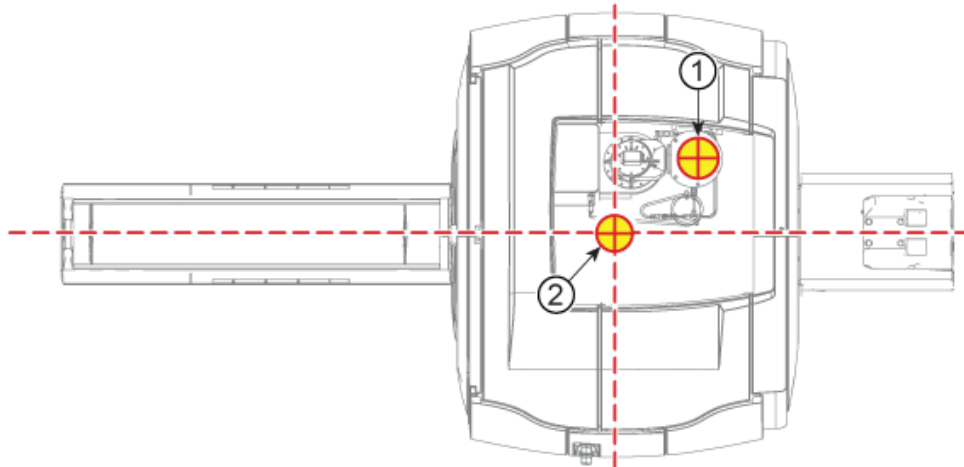

Item	Description
1	Vent center
2	Magnet isocenter

3.5.4 Doors, Magnet Access Openings, and Patient Viewing Windows



1. The finished opening of the Magnet Room main door must be at least 1092 mm (43 in.) wide to allow for helium dewars and patient tables.
2. Threshold height must not exceed 15 mm (0.6 in.) on both sides of the door with a maximum 10-degree threshold inclination.
3. IEC requires the patient, while in the bore, be in full view of the operator.



NOTE

- GE HealthCare recommends using a window, although other means (for example, camera and video display) may be used as long as all IEC requirements are met.
 - The recommended dimensions for the patient viewing windows are 1219 mm wide x 762 mm high (48 in. wide x 30 in. high).
 - The recommended distance from the bottom edge of the patient viewing window to the finished floor is 1067 mm (42 in.).
4. The magnet delivery requires an opening into the room to allow access for the magnet delivery, rigging, and personnel access.

3.5.5 Finished Ceiling



1. The customer is responsible for the finished ceiling.
2. The finished ceiling grid must be non-ferrous.
3. Ceiling preparation should be completed prior to magnet delivery.

3.5.6 Magnet Room Floors



1. The finished floor must support the weight of all components throughout operation and service life. This includes the magnet, patient table, and gradient coil replacement cart.



NOTE

For gradient coil replacement, field engineers remove the patient table from the Magnet Room before they move the gradient coil replacement cart into the Magnet Room.

2. The finished floor must be water resistant to protect the subfloor and shielding from water damage.
3. The customer is responsible for providing flooring to prevent ESD (Electrostatic Discharge) buildup to 8 kV for protection of the sensitive MR equipment.
4. Magnet, Enclosure, and Patient Table areas must be flat and level within 3 mm (0.125 in.), with the magnet in place, within the shaded area shown in [Figure 3-13 Magnet Room Floor Levelness Area on page 100](#).

Figure 3-13 Magnet Room Floor Levelness Area

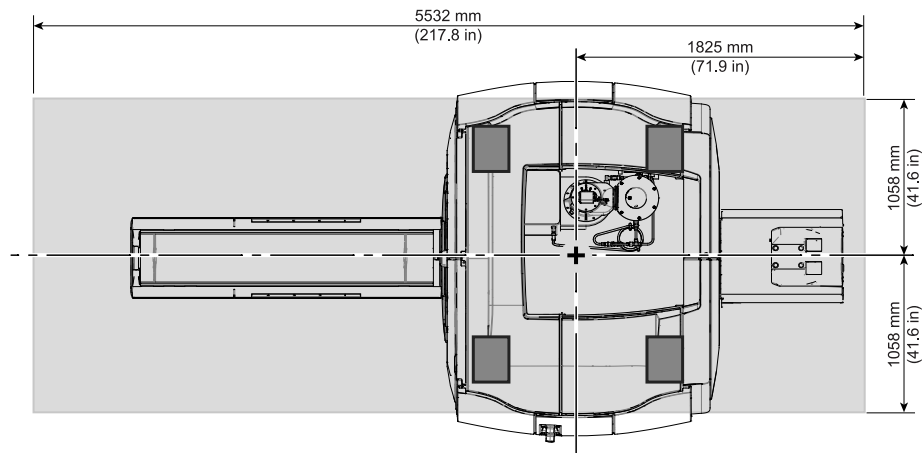

5. The VibroAcoustic Dampening kit for both seismic and non-seismic mounting is M50002LP. See [Figure 3-14 Magnet Mounting Detail - Patient End is on the Left Side on page 101](#) for details.
6. Seismic anchors must be isolated from rebar.
7. A 102 mm (4 in.) rebar-free area is necessary under the table dock anchor, in the position shown in [Figure 3-14 Magnet Mounting Detail - Patient End is on the Left Side on page 101](#).



IMPORTANT

The table dock anchor hole is drilled only after magnet installation.

Figure 3-14 Magnet Mounting Detail - Patient End is on the Left Side

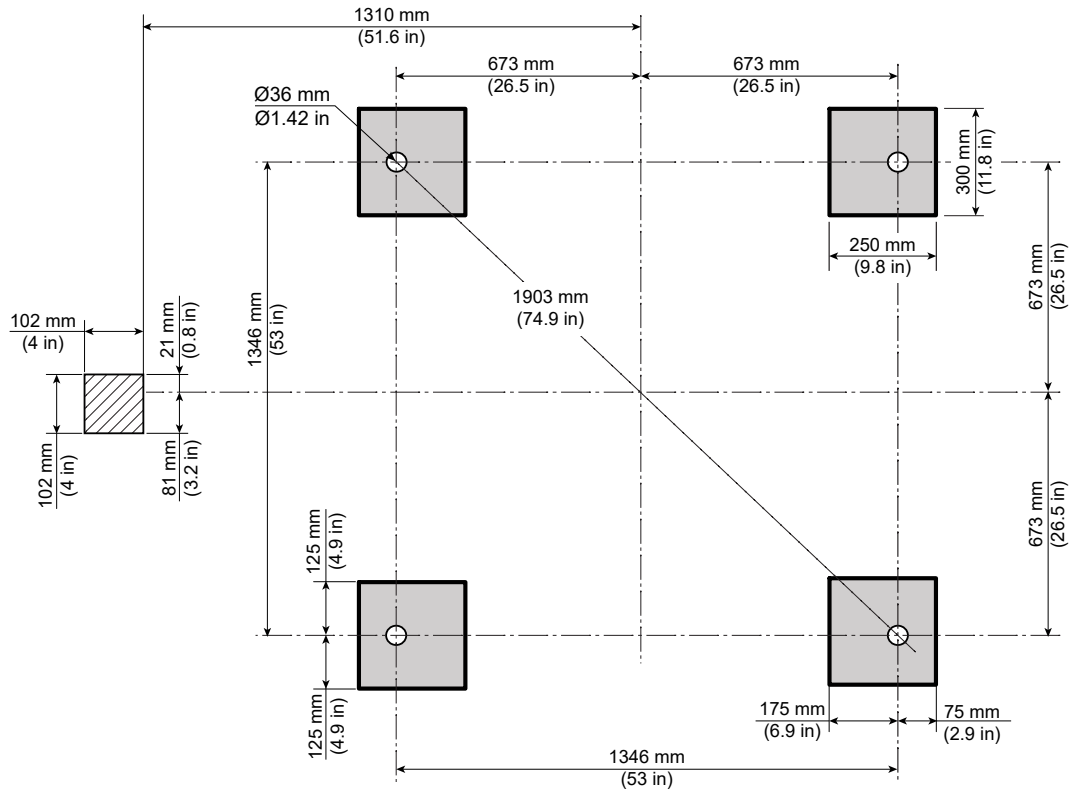

8. RF shield seams, joints, or overlaps must not be located under the VibroAcoustic mats.

3.5.7 Storage Cabinets



NOTE

GE HealthCare no longer provides a storage solution for system phantoms.

1. The customer shall provide storage for phantoms in the magnet room (for example, a cart, shelving unit or cabinet). Storage needs to be large enough to accommodate system phantoms listed in Table 1-1 of *Customer Site Storage Requirements*, 5182674 (available in the Customer Documentation Portal).
2. The storage solution can not interfere with the magnet room minimum service area.

3.6 Magnet Room Equipment Specifications



(Applies to all subsections within this section)

3.6.1 Magnet (MAG) Assembly Specifications

- Magnet weight, with cryogenics at maximum capacity: 5320 kg (11700 lb.)

Figure 3-15 Magnet (MAG) Dimensions and Rear Pedestal

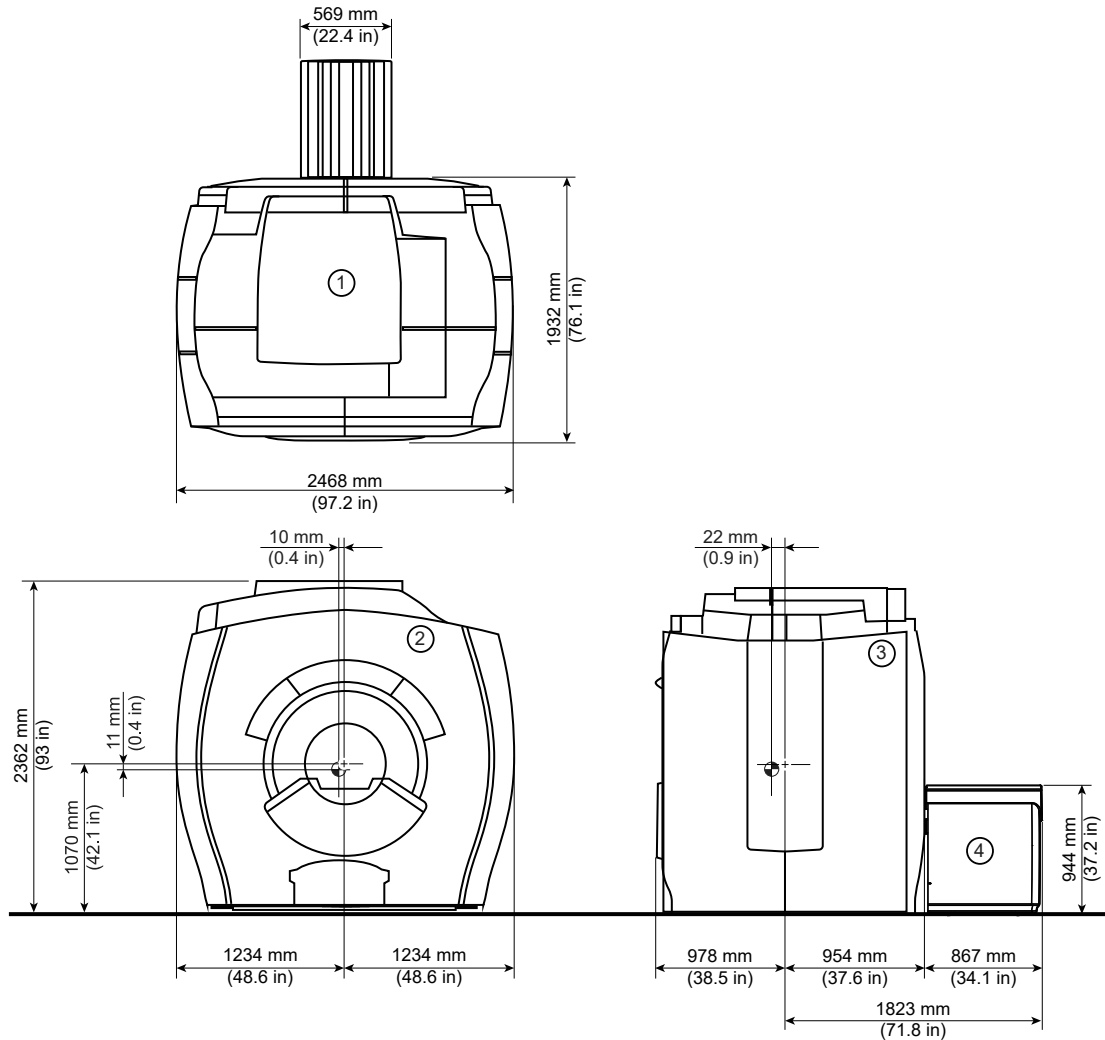

Item	Description	Item	Description
1	Top view	3	Side view
2	Front view	4	Rear pedestal

Figure 3-16 Recommended duct space behind rear pedestal

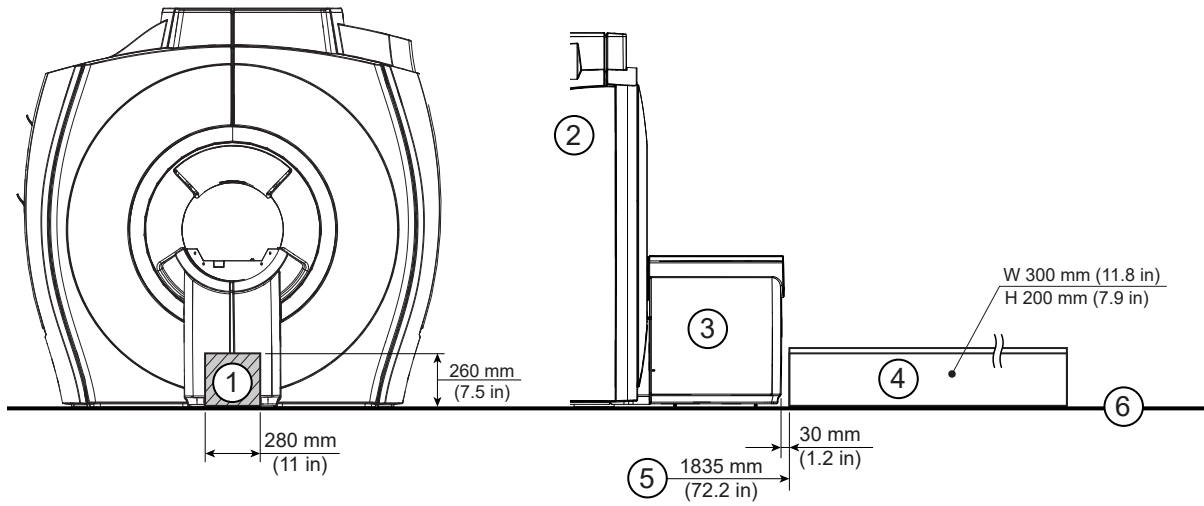

Item	Description	Item	Description
1	Cover for rear cable access	4	Floor duct
2	Magnet	5	From magnet isocenter
3	Rear pedestal	6	Finished floor

Figure 3-17 Limitation of Duct size for Minimum Room layout

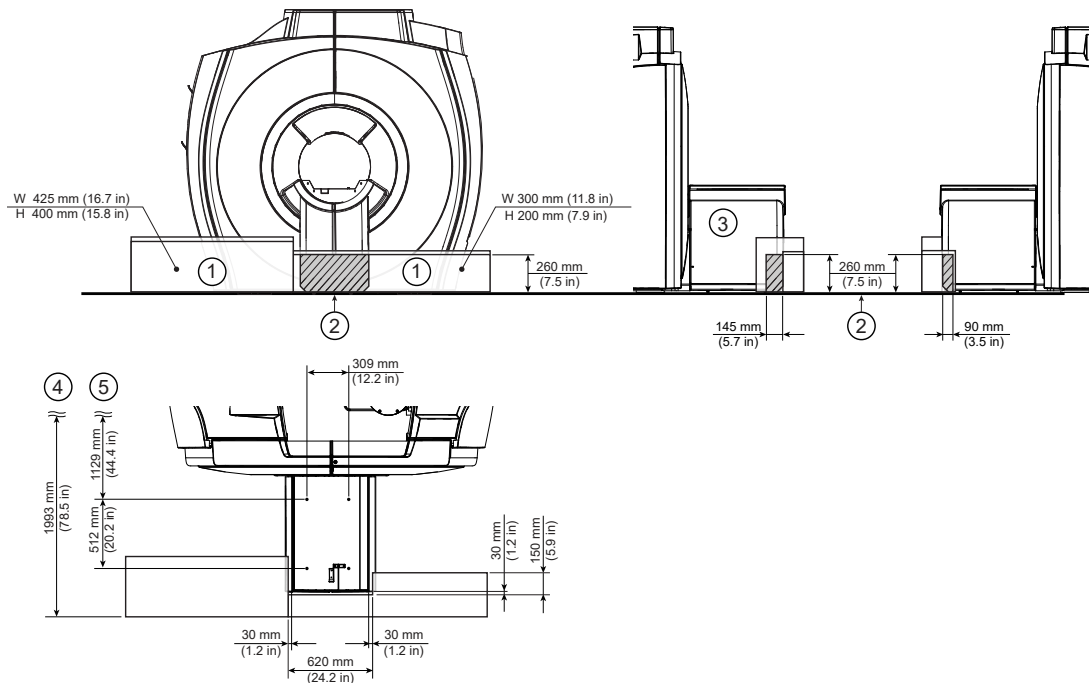

Item	Description	Item	Description
1	Floor duct	4	From magnet isocenter to floor duct
2	Finished floor	5	From magnet isocenter
3	Rear pedestal	-	-



NOTE

Add edge guards or tape to the cut edge of rear pedestal covers.

30 mm (1.18 in.) minimum clearance is required between rear pedestal and surface of duct.

Shaded area of rear pedestal shows the cutout area.

3.6.2 Patient Table (PT) Specifications

1. Detachable Lite Table weight, empty: 150 kg (330 lb.)
2. Detachable Lite Table weight, including maximum patient weight of 159 kg (350 lb.) and accessories: 338 kg (744 lb.)
3. Detachable Standard Table weight, empty: 127 kg (280 lb.)
4. Detachable Standard Table weight, including maximum patient weight of 159 kg (350 lb.) and accessories: 315 kg (693 lb.)
5. Low Height Fixed Table weight, empty: 136 kg (300 lb.)
6. Low Height Fixed Table weight, including maximum patient weight of 200 kg (440 lb.) and accessories: 366 kg (807 lb.)

Figure 3-18 Detachable Lite Table

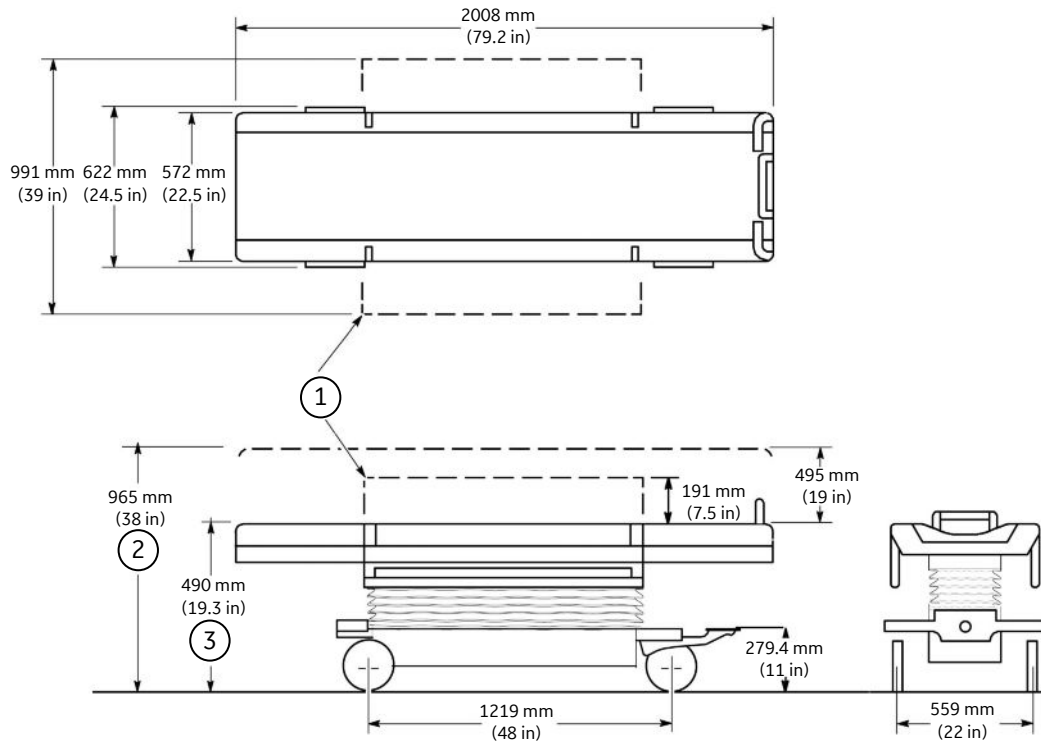

Item	Description	Item	Description
1	Side rail extended	3	Min table elevation
2	Max table elevation		

Figure 3-19 Detachable Standard Patient Table (PT)

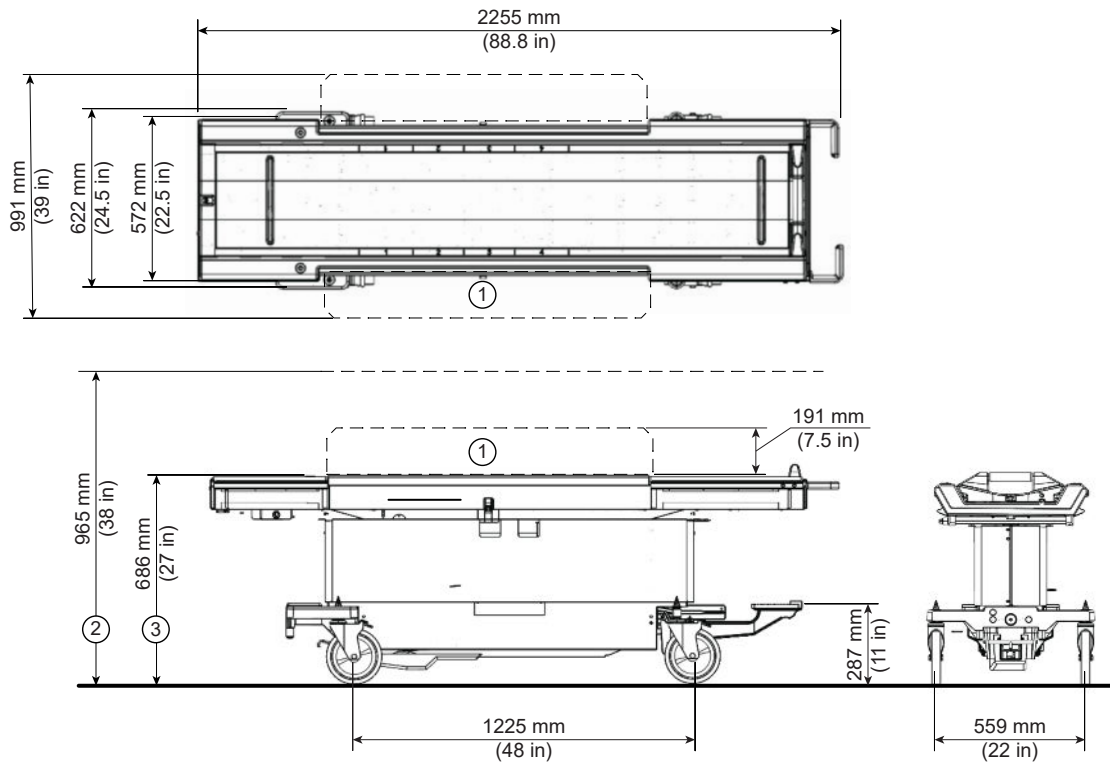

Item	Description	Item	Description
1	Side rail extended	3	Min table elevation
2	Max table elevation		

Figure 3-20 Low Height Fixed Patient Table (PT)

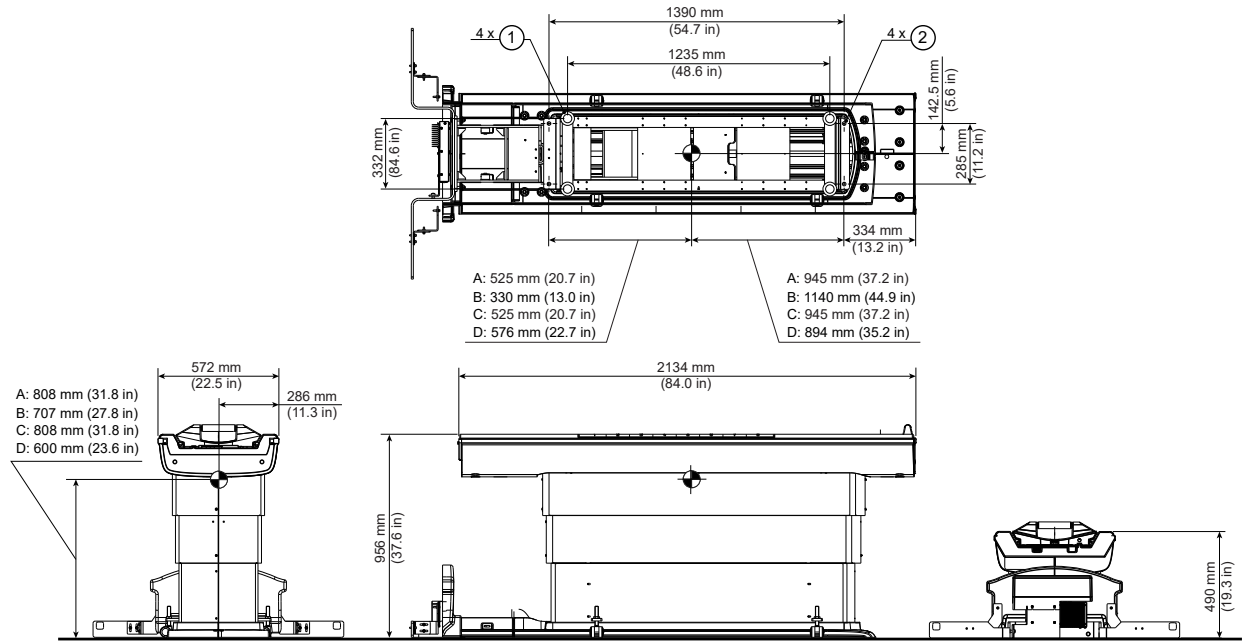

Item	Description	Item	Description
A	336 kg (741 lb.): Patient is on the table being prepared for scanning, not in the bore. Table is at the highest position.	C	336 kg (741 lb.): Patient is on the table and cradle is 50 mm (2 in.) into the bore. Table is at the highest position.
B	196 kg (432 lbs.): Patient is moved 1470 mm (58 in.) into the bore and scanning. Table is at the highest position.	D	136 kg (300 lbs.): Patient is not on the table. Table is at the highest position.
1	Leveling Pad	2	4 Seismic mounting holes, \varnothing 17.2mm (0.68 in.)

3.6.3 Magnet Rundown Unit (MRU) Specifications and Requirements

1. Location: The bottom edge of the MRU must be mounted 1524 ± 25 mm (60 ± 1 in.) above the Magnet Room floor near the front of the magnet enclosure.
2. Weight: 3.2 kg (7 lb.)
3. Magnetic Field Limit: 20 mT (200 G)
4. The MRU is installed by the facility contractor.

Figure 3-21 Magnet Rundown Unit (MRU)

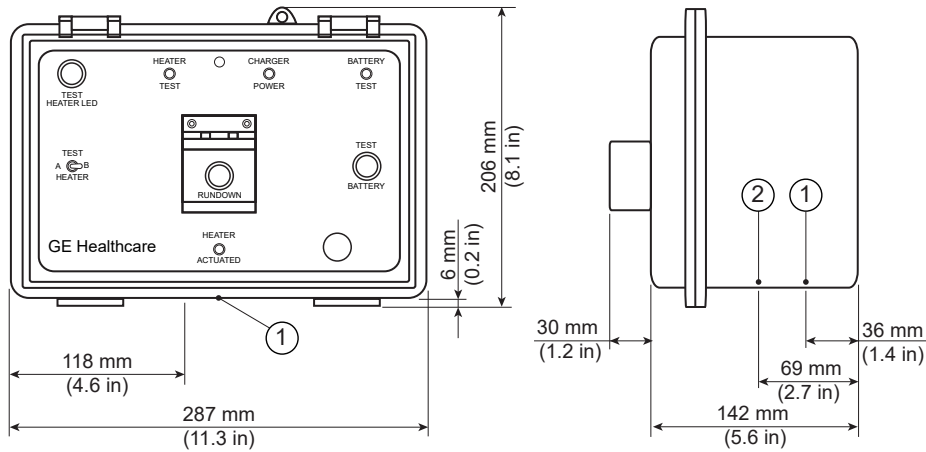

Item	Description
1	Cable access
2	Power access

Figure 3-22 MRU Mounting Pattern

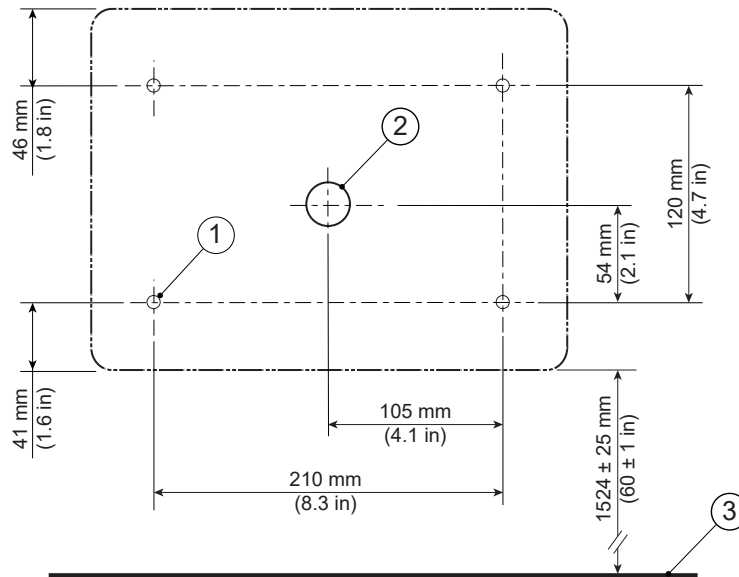

Item	Description	Item	Description
1	7 mm (0.275 in.) diameter mounting hole	3	Finished floor
2	26 mm (1.025 in.) diameter cable access	-	-

3.6.4 Blower Box

CAUTION



THE BLOWER BOX CONTAINS MAGNETIC MATERIAL WHICH CAN BE ATTRACTED TO THE MAGNET.

The Blower Box must be securely mounted to the floor of the Magnet Room or a support shelf on the Magnet Room wall or ceiling with support provided under the box.



IMPORTANT

The Blower Box must be securely mounted per preceding Caution. Therefore the Blower Box must not be on a raised floor section within the Magnet Room. RF Shield integrity must be maintained when considering mounting method.



NOTE

Blower Box mounting requires customer-supplied hardware (lag bolts, screws, and so on) appropriate for the surface on which the box will be mounted.

The Blower Box provides cooling air for the RF/Gradient Body Coil and the Patient Comfort Module in the Magnet Enclosure. The Blower Box shall be mounted within the RF shielded room and connects to the Gradient Coil and the Patient Comfort Module by 165.1 mm (6.5 in.) OD and 114.3 mm (4.5 in.) OD flexible vinyl air ducting. The flexible vinyl air duct routes from the Blower Box through the Magnet Enclosure Rear Pedestal cable access and connects to the Patient Comfort Module in the Magnet Enclosure.

1. Weight: 21 kg (47 lb.)
2. Magnetic Field Limit: 20 mT (200 G)

Figure 3-23 Blower Box

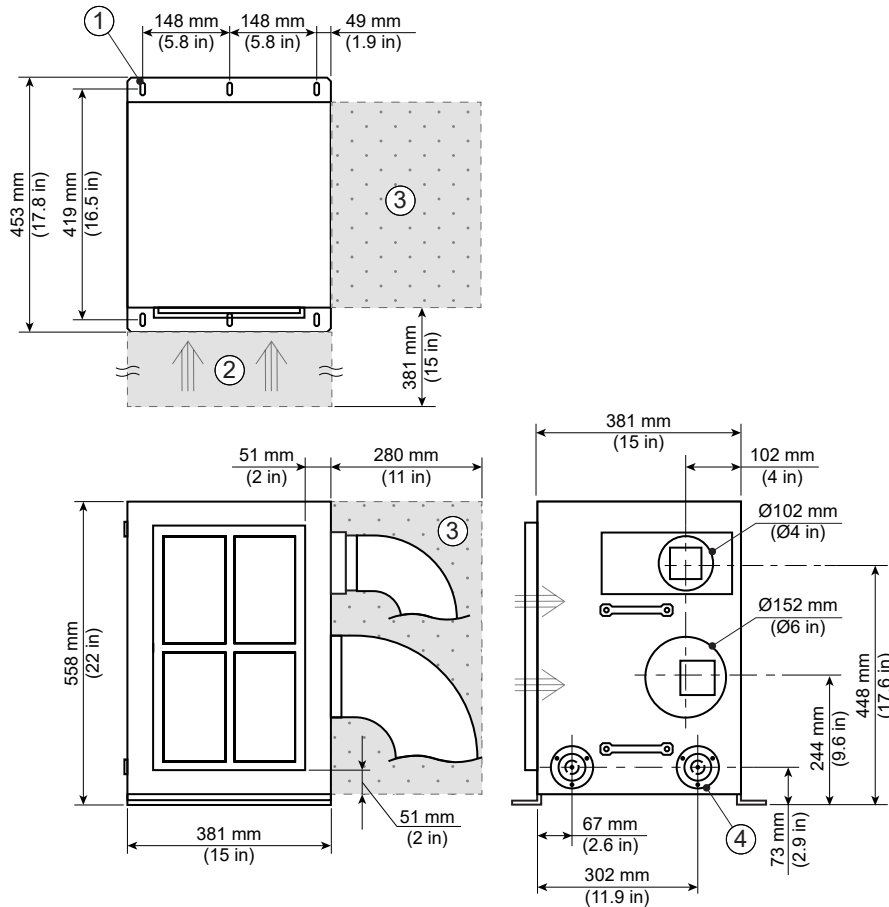

Item	Description	Item	Description
1	6 holes for M6 lag bolts or screws. See note.	3	Duct trim cover
2	Air in-take clearance	4	Interconnect cable



NOTE

The blower box should be anchored with M6 bolts which can stand 0.217 kN (48.78 lb.) shear force and 0.076 kN (17.09 kN) tension force.

More strict requirements may apply in seismic regions.

3.7 Magnet Room Lighting Requirements



1. All lighting fixtures and associated components must meet all RF shielded room and RF grounding requirements (for example, track lighting is not recommended due to possible RF noise).
2. All removable lighting fixtures and associated components must be non-magnetic.
3. All lighting must use direct current (the DC must have less than 5% ripple).

4. At least 300 lux must be provided at the front of the magnet for patient access and above the magnet for servicing.
5. Fluorescent lighting must not be used in the Magnet Room.
6. Lighting must be adjusted using a discrete switch or a variable DC lighting controller.
7. SCR dimmers or rheostats must not be used.
8. DC LED lighting may be used if the DC power converter and RF sources are all located outside the Magnet Room RF Shield.

**NOTE**

LED lighting could cause image quality issues due to RF interference. Make sure a MR-compatible LED lighting solution is chosen.

9. Battery chargers (for example, used for emergency lighting) must be located outside the Magnet Room.
10. LED Lighting or short filament length incandescent bulbs are recommended.
11. Linear lamps are not recommended due to the high burnout rate.

4 Equipment Room

4.1 Equipment Room Overview



(Applies to all sections within this chapter)

The following illustration shows minimum equipment room service clearances. Refer to [MR Suite Minimum Room Size Requirements on page 21](#) for a list of considerations not included in the minimum area dimensions.

**NOTE**

Colored areas indicate service/installation areas. These areas can overlap as necessary as shown below. See individual component descriptions and room requirements for service area details. Optional equipment is not shown; additional space may be required for options.

**NOTE**

The following illustrations show equipment layouts based on the assumption that cooling components and step down transformers must be re-positioned during some service activities.

**NOTE**

Refer to [Table 2-25 MR System Component Replacement Shipping Specifications on page 81](#) for the dimensions of the replacement parts. The parts must be able to be positioned in front of the noted cabinet for replacement procedures after the system has been installed.

Figure 4-1 Typical Minimum Equipment Room with Service Clearances (Type C)

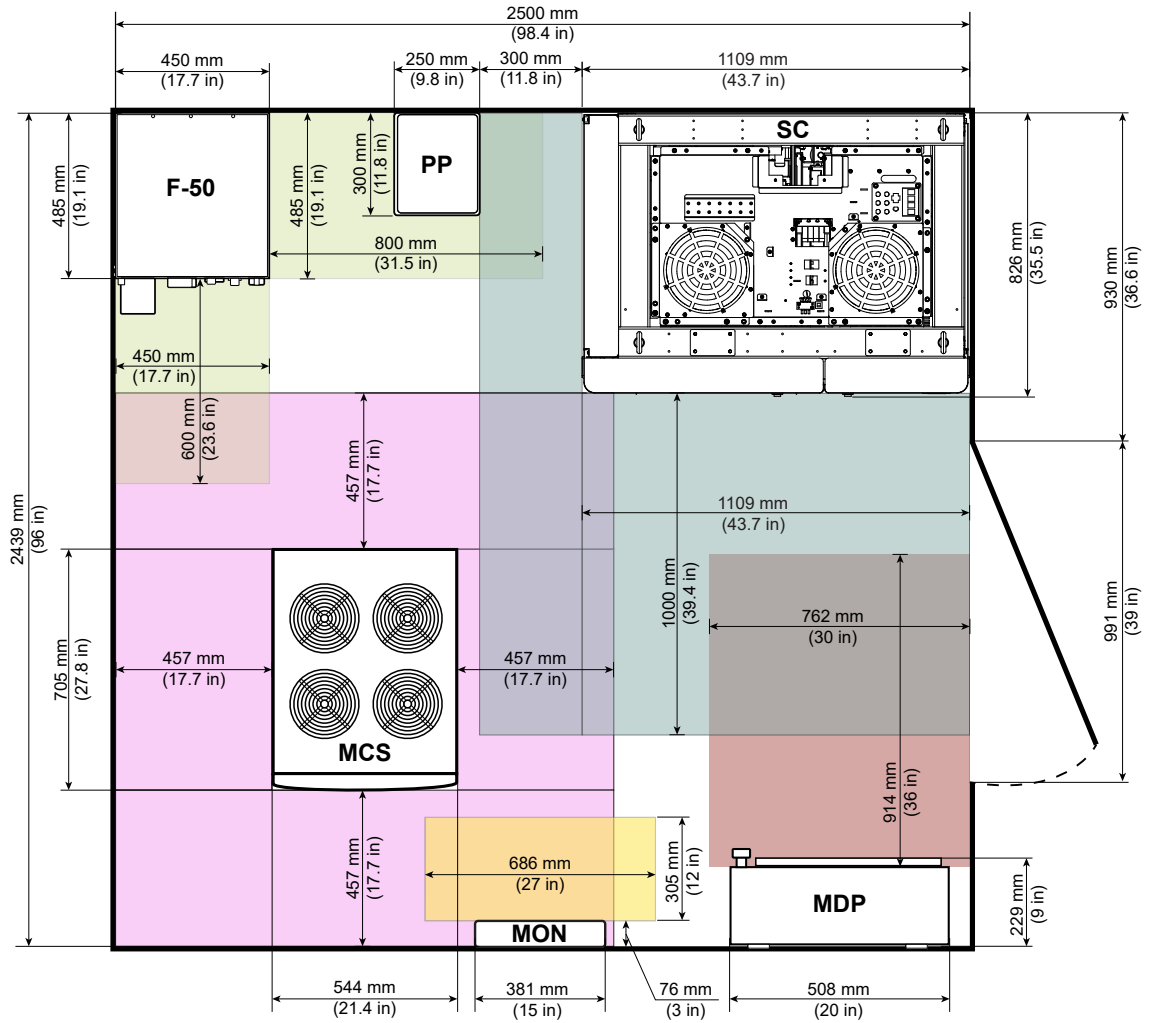

Figure 4-2 Typical Minimum Equipment Room with Service Clearances (Type D)

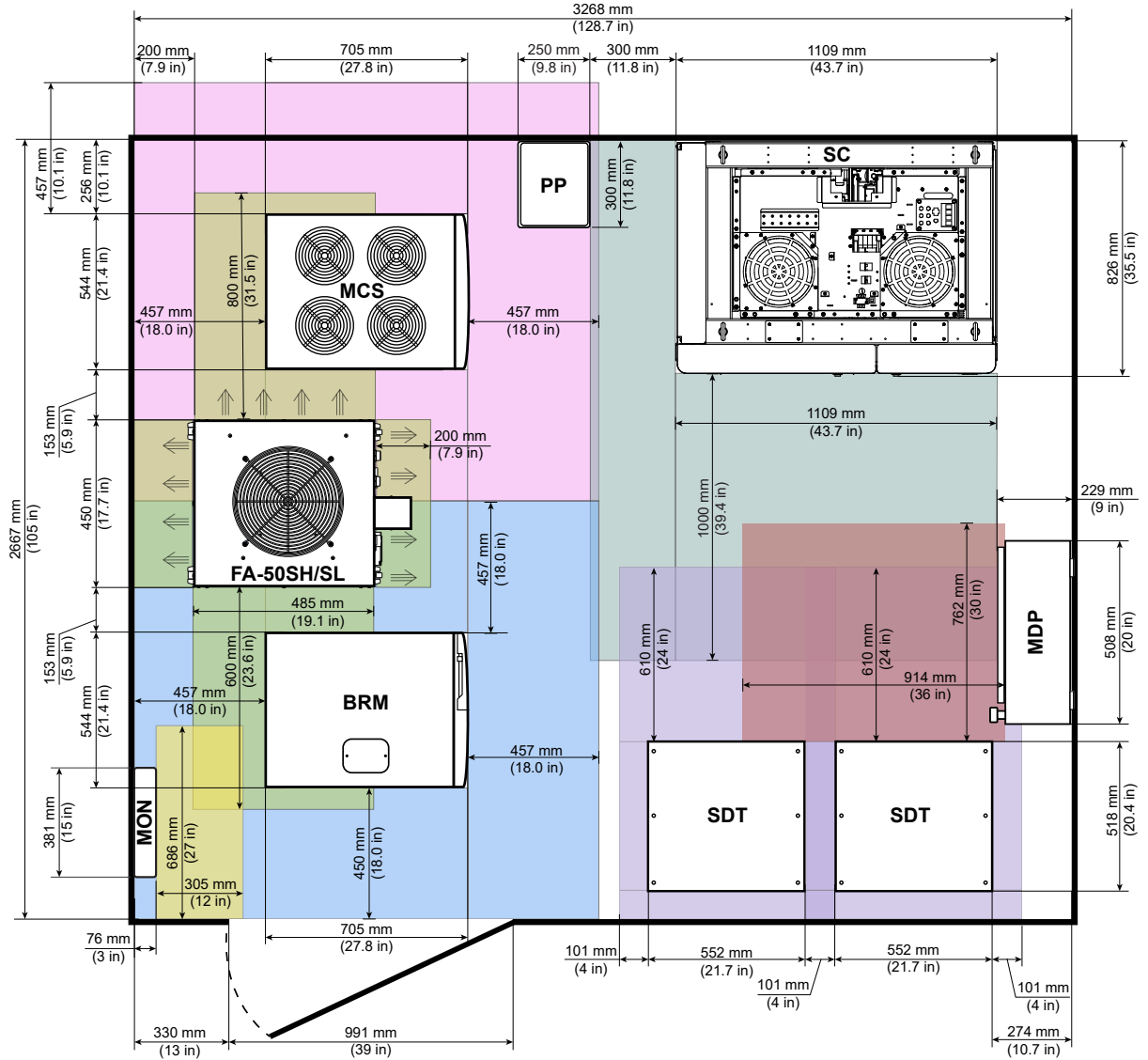
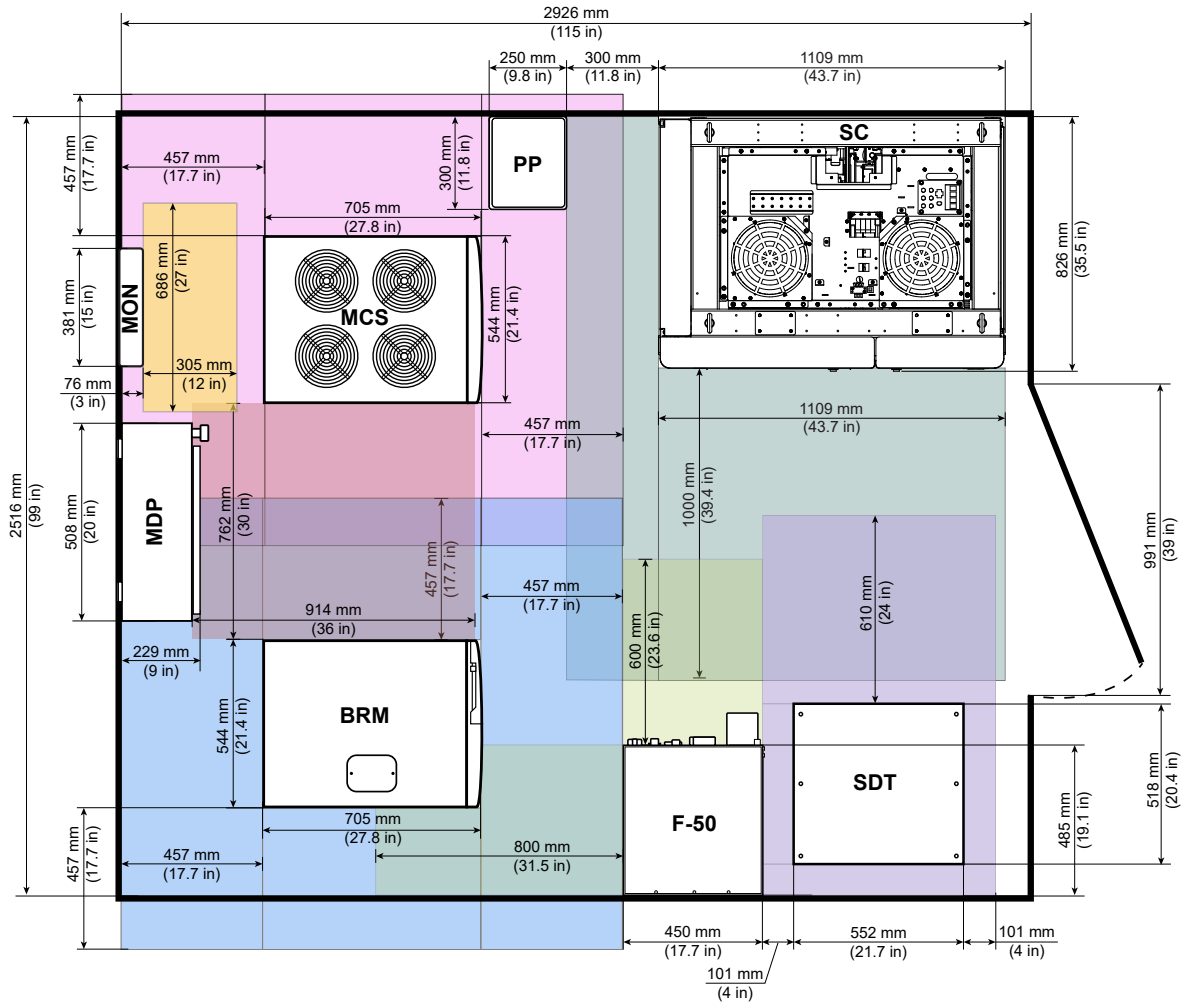

Figure 4-3 Typical Minimum Equipment Room with Service Clearances (Type E)



4.2 Main Disconnect Panel (MDP) Requirements and Specifications

4.2.1 Requirements

1. It is recommended to install the following items to support a power monitor:
 - 1.1. A T100 network connection with RJ45 connector near the MDP
 - 1.2. An electrical outlet
2. The cable must be Cat 5 or better.
3. The network connection must not be routed through the Ethernet switch in the Global Operator Cabinet (GOC).

4.2.2 Specifications

The Main Disconnect Panel (MDP) is provided with the MR System. Only exempt countries can supply their own MDP (see [2.10.3 Customer-supplied Main Disconnect Panel \(MDP\) Requirements \(exempt countries only*\)](#) on page 70).

M50022MB and M50022MC

1. **M50022MB**, Weight: 61 kg (134 lb).
2. **M50022MC**, Weight: 60 kg (132 lb).
3. Magnetic Field Limit: 5 mT (50 G)

Figure 4-4 GE HealthCare supplied Main Disconnect Panel (MDP) M50022MB and M50022MC

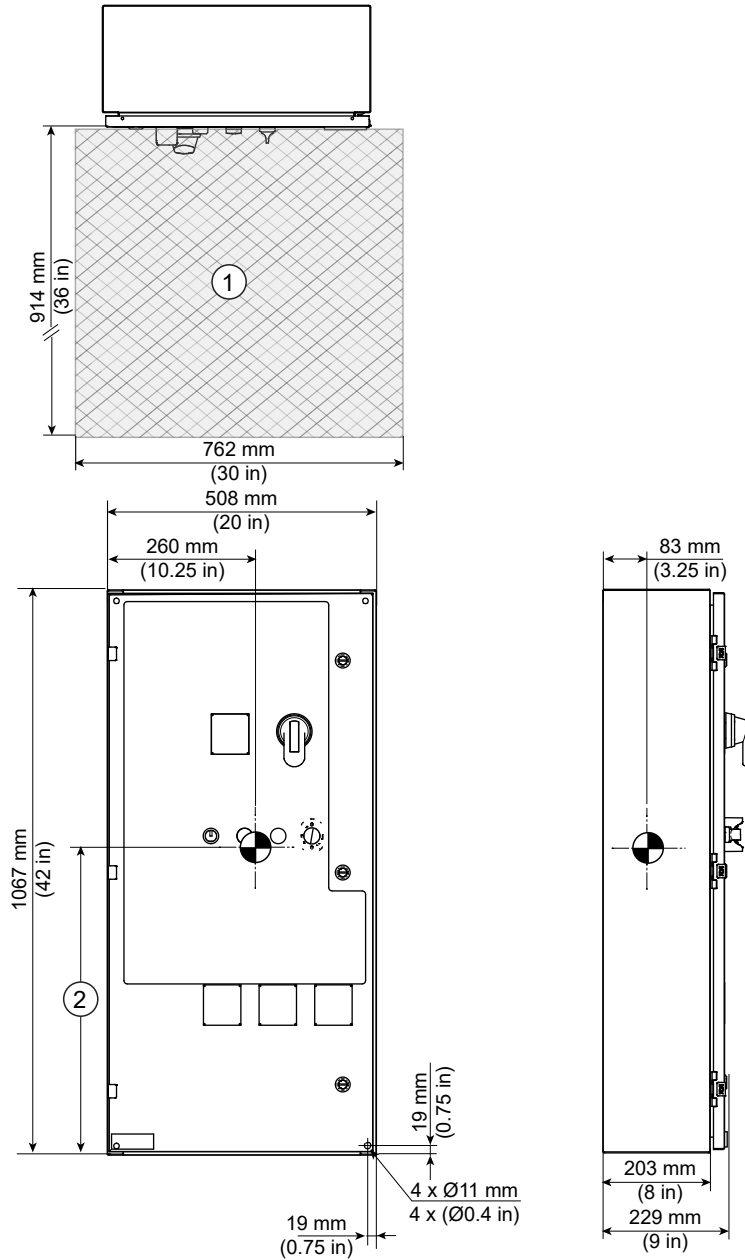

Item	Description
1	Service Clearance
2	Center of gravity dimension for M50022MB is 552 mm (21.75 in)
	Center of gravity dimension for M50022MC is 546 mm (21.5 in)

4.3 System Cabinet (SC)

Weight: 956 kg (2108 lb).

Magnetic Field Limit: 5 mT (50 G) (Penetration Panel (Back Panel) side)

Contact Area: 2461.76 mm² (3.82 in²) for each support. There are 6 supports in total.

Figure 4-5 System Cabinet

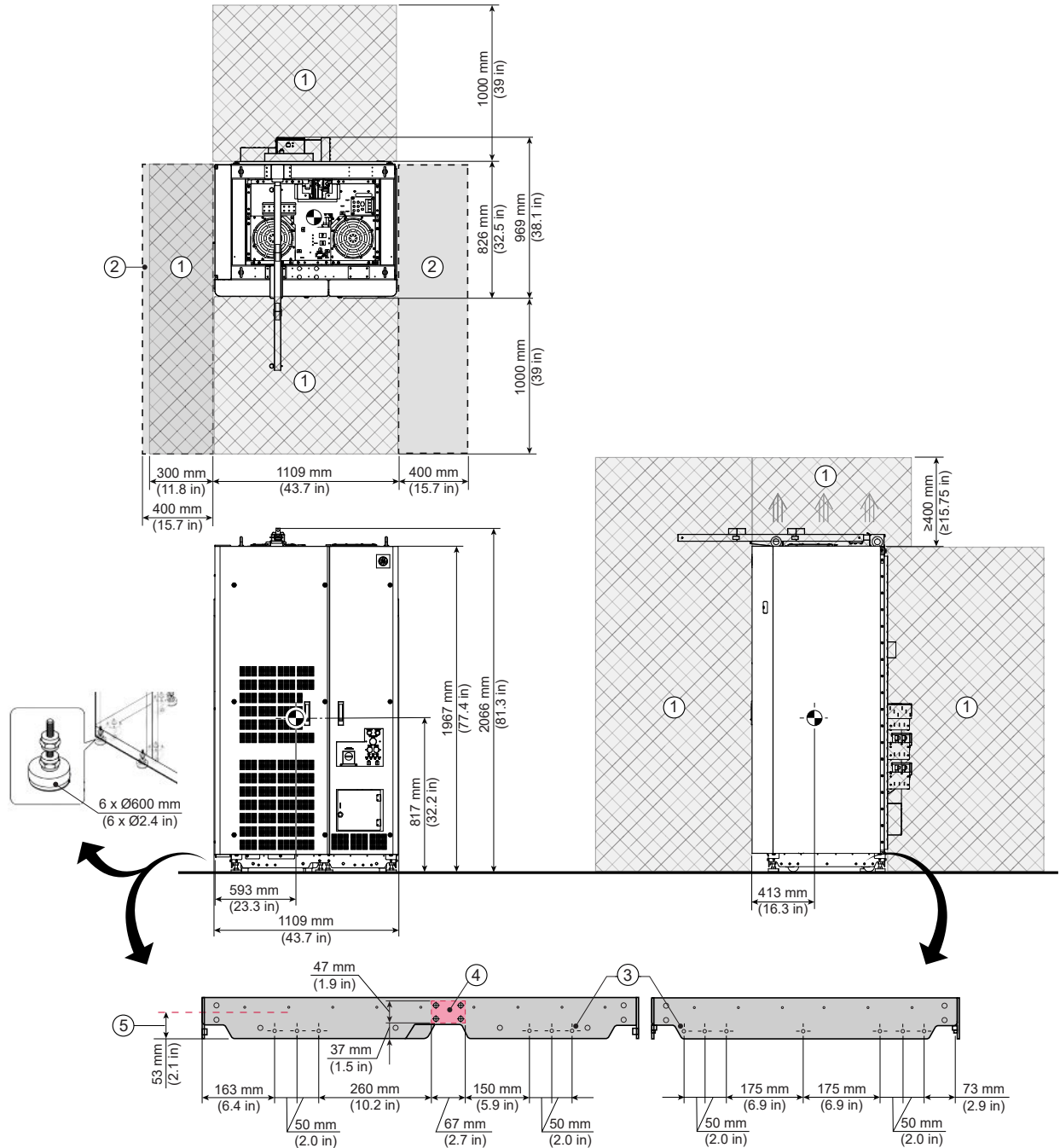

Item	Description	Item	Description
1	Service clearance	2	Installation clearance
3	Seismic anchor mounting holes (All M8-1.25)	4	Customer-supplied seismic mounting bracket shall not interfere with the highlighted area.
5	Maximum height of Customer-supplied seismic mounting bracket	-	-



NOTE

Make sure that the seismic brackets and anchors do not conflict with SC covers and water hose routing.

Area must be level according to the specification in [Figure 4-6 Area to be leveled on page 119](#).

Figure 4-6 Area to be leveled

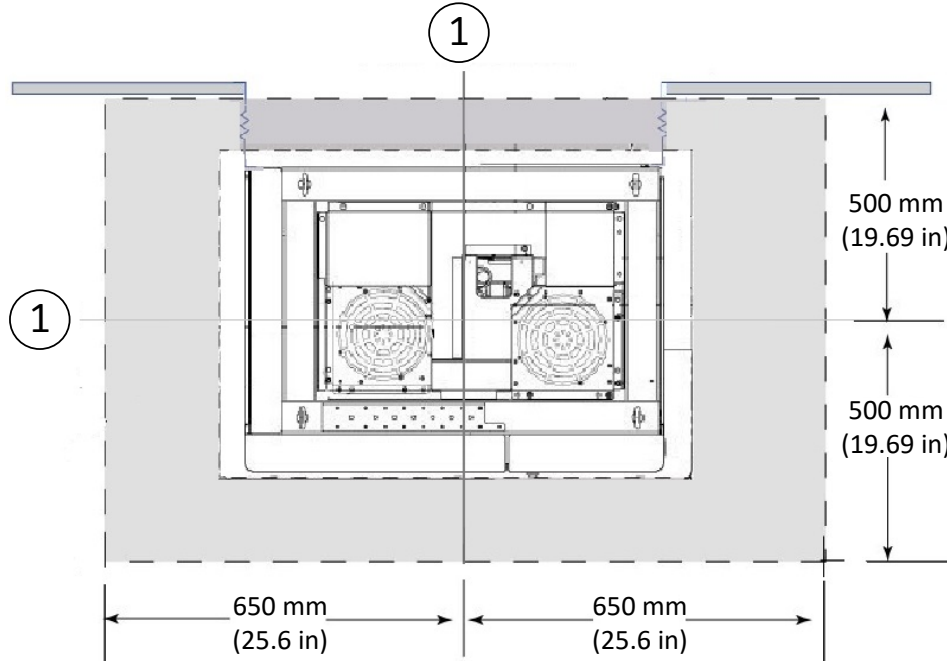

Item	Description
1	Base Center



NOTE

Shaded area must be leveled.

Specification of Floor

1. Floor slope: $< \pm 0.5$ deg
2. Floor surface: $< \pm 5$ mm
3. Non-compressible flooring material only. For example, no carpet allowed.

4.4 Mesh Shield and System Cabinet (SC) Cover

Figure 4-7 Mesh Shield and SC Cover on page 120 shows the relationship and dimensions of SC, RF shield wall, Mesh Shield and Cover.

Figure 4-7 Mesh Shield and SC Cover

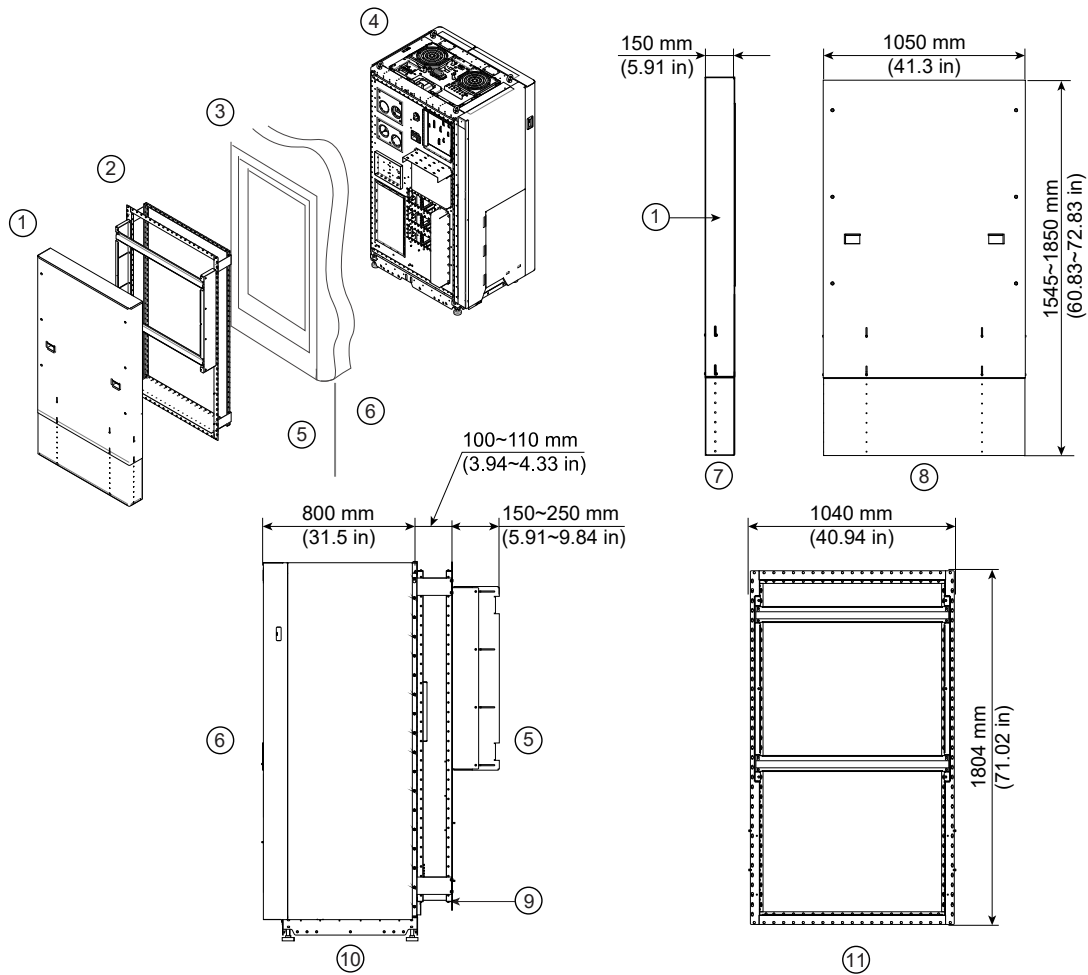

Item	Description	Item	Description
1	Cover	2	Mesh Shield ISC
3	Wall Cut Out	4	SC
5	Magnet Room	6	Equipment Room
7	Side View of Cover	8	Front View of Cover
9	Surface attached to RF shield layer	10	Side View of SC
11	Front View of Mesh Shield	-	-

4.5 Penetration Panel

Magnetic Field Limit: 20 mT (200 gauss)

Figure 4-8 Penetration Panel (PP) and Cover

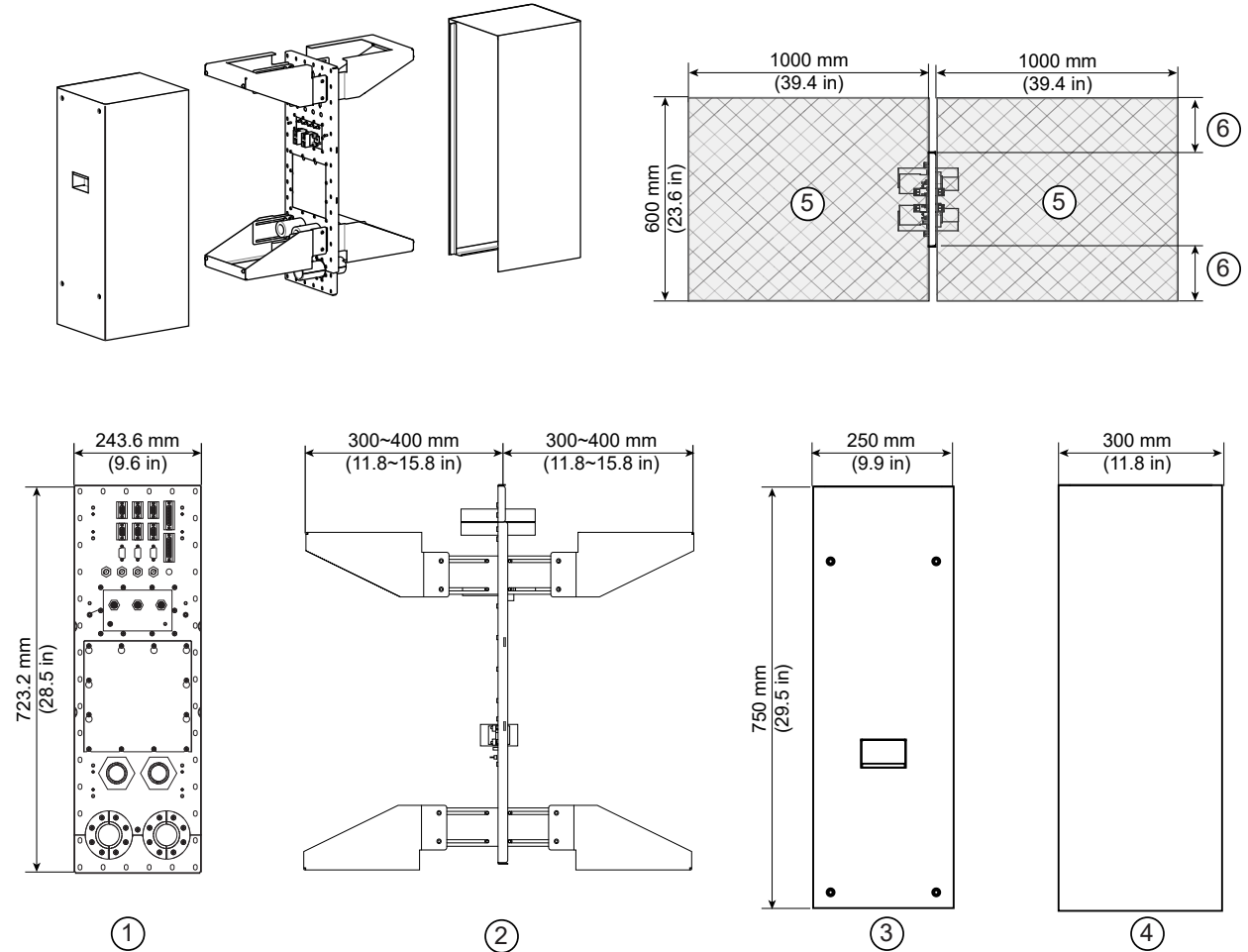

Item	Description	Item	Description
1	Penetration Panel Front View	2	Penetration Panel and Frame Side View
3	Penetration Panel Cover Front View	4	Penetration Panel Cover Side View
5	Service Clearance	6	Minimum Service Clearance at each side is 60 mm (2.4 in.). The Penetration Panel (PP) does not need to be centered in the Service Clearance.

4.6 Cryocooler Compressor (CRY) Specifications

- F-50L Cryocooler Compressor Weight: Approx 120 kg (264 lb.)
 F-50SH Cryocooler Compressor Weight: Approx 120 kg (264 lb.)
 FA-50SL/FA-50SH Cryocooler Compressor Weight: Approx 155 kg (342 lb.)

2. Magnetic Field Limit: 10 mT (100 G)

Figure 4-9 Cryocooler Compressor F-50L (Water Cooled)

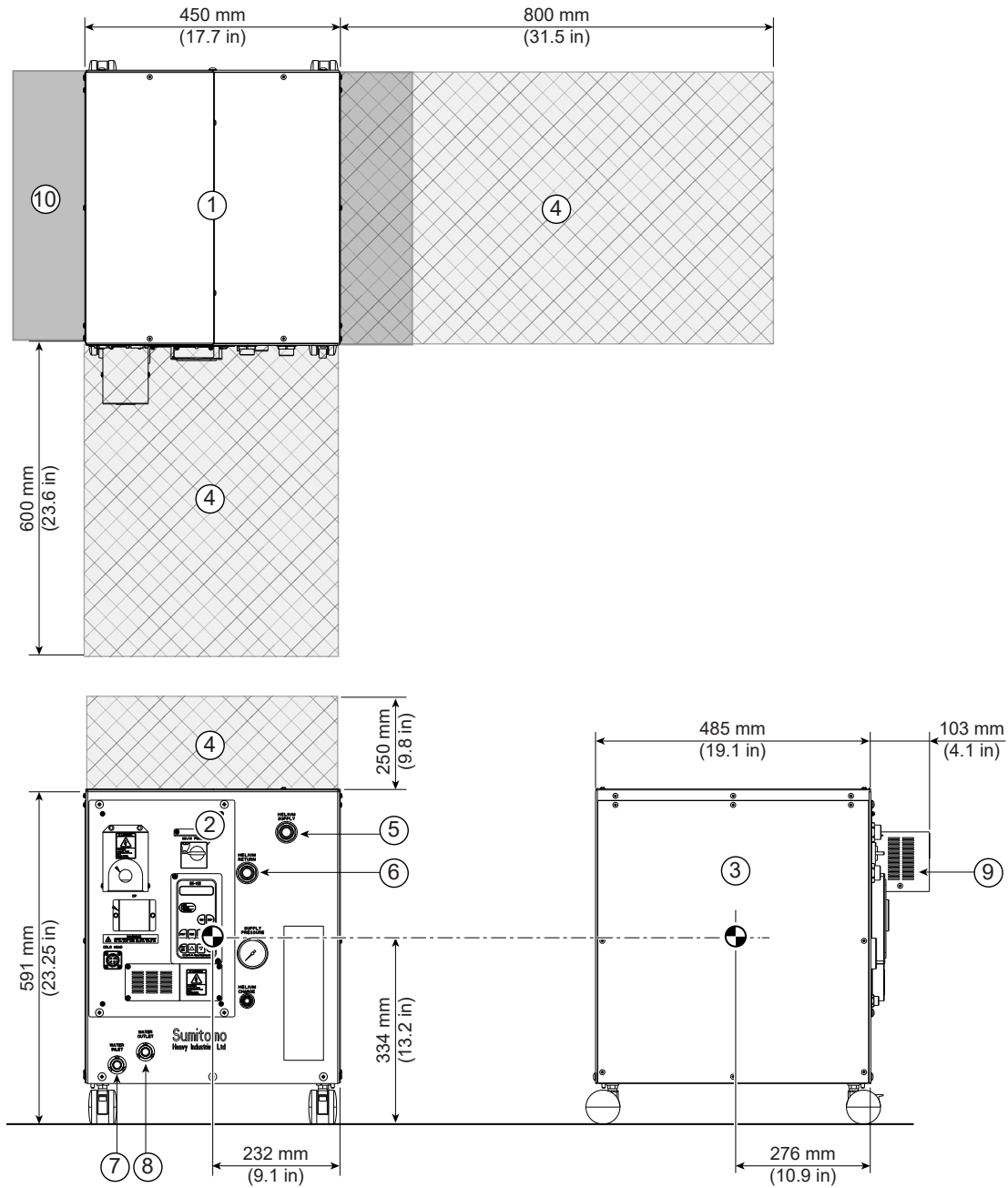

Item	Description	Item	Description
1	Top view	6	Helium return
2	Front view	7	Water supply
3	Side view	8	Water return
4	Service clearance	9	Input power terminal
5	Helium supply	10	Clearance for seismic installation

Figure 4-10 Cryocooler Compressor F-50SH (Water Cooled)

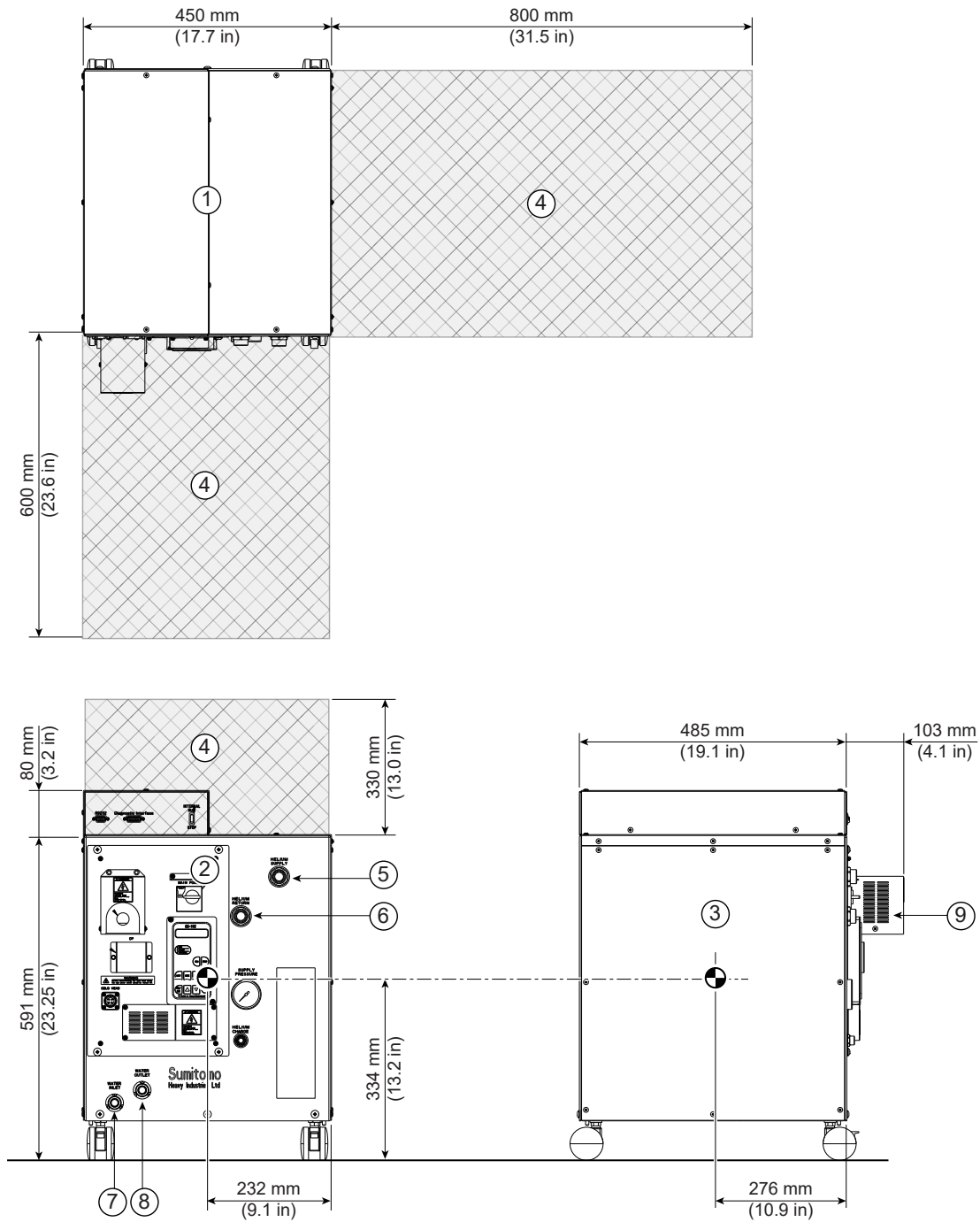

Item	Description	Item	Description
1	Top view	6	Helium return
2	Front view	7	Water supply
3	Side view	8	Water return
4	Service clearance	9	Input power terminal
5	Helium supply	-	-

Figure 4-11 FA-50SL/FA-50SH Cryocooler Compressor (Air Cooled)

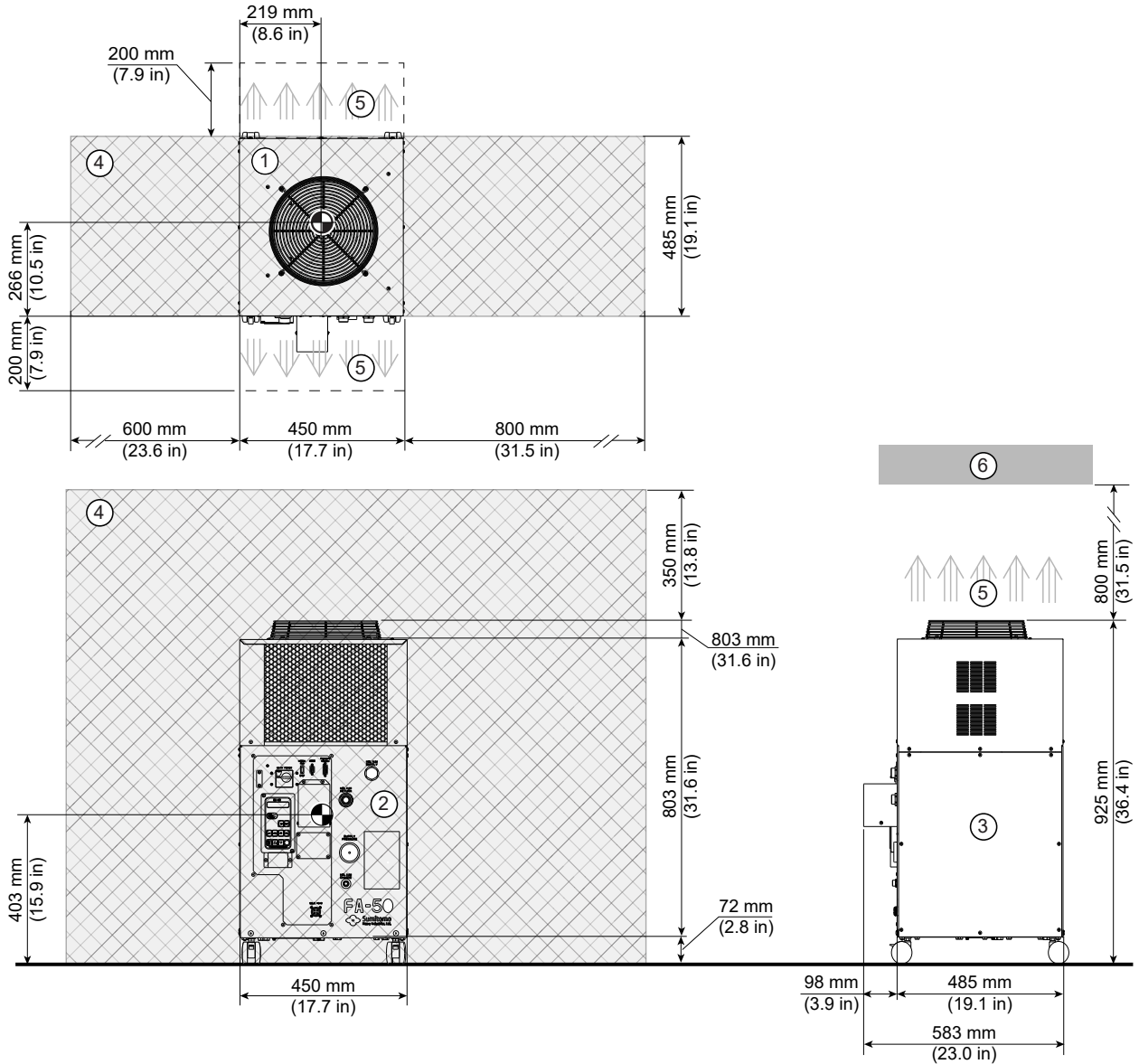

Item	Description	Item	Description
1	Top view	2	Front view
3	Side view	4	Service area
5	Air clearance	6	Ceiling

4.7 4 kW LCS (LCS4) and 8 kW LCS (LCS8)

For 8 kW LCS

1. Empty weight: 48.5 kg (107 lb.)
2. With full filled coolant weight: 73.5 kg (162 lb.)

For 4 kW LCS

1. Empty weight: 39 kg (86 lb.)
2. With full filled coolant weight: 64 kg (141 lb.)

Magnetic Field Limit: 5mT (50 G)



NOTE

Both 4 kW and 8 kW LCS are the same size.

Keep 457 mm (18 in.) from at least two sides of the water chiller for airflow.

Figure 4-12 4 kW or 8 kW LCS

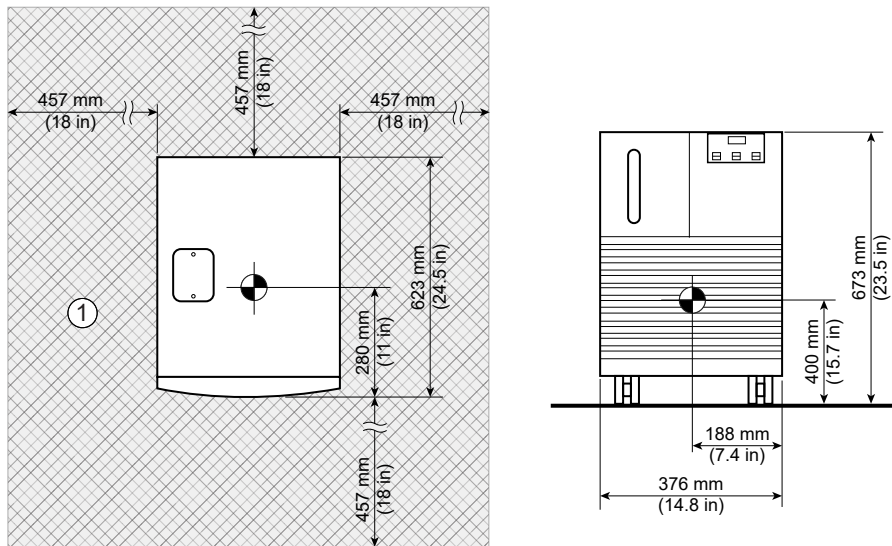

Item	Description
1	Service Area

4.8 MCS

Empty weight: 100 kg (221 lb.)

With full filled coolant weight: 130 kg (286 lb.)

Magnetic Field Limit: 5 mT (50 G)



NOTE

Keep 457 mm (18 in.) from at least two sides of the water chiller for airflow.

Figure 4-13 MCS

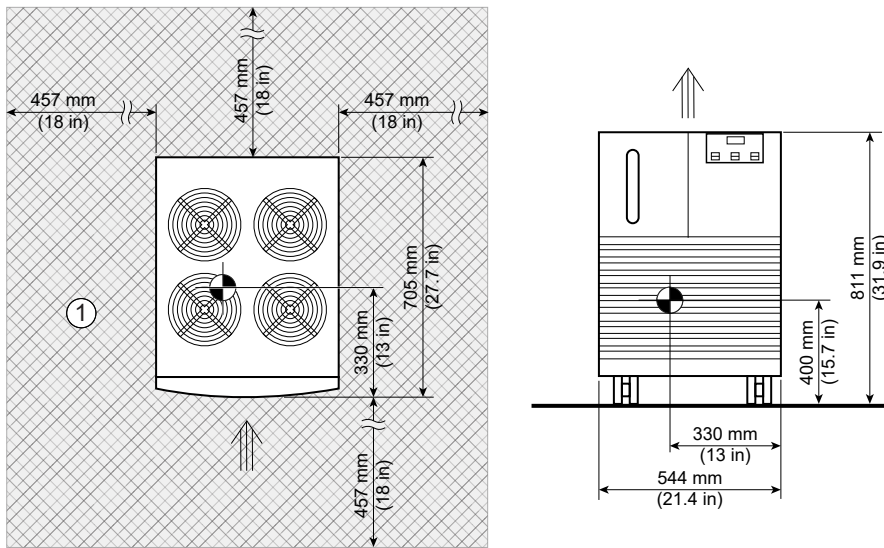

Item	Description
1	Service Area

4.9 BRM Chiller

Empty weight: 134 kg (295 lb.)

With full filled coolant weight: 159 kg (350 lb.)

Magnetic Field Limit: 5 mT (50 G)

Figure 4-14 BRM Chiller

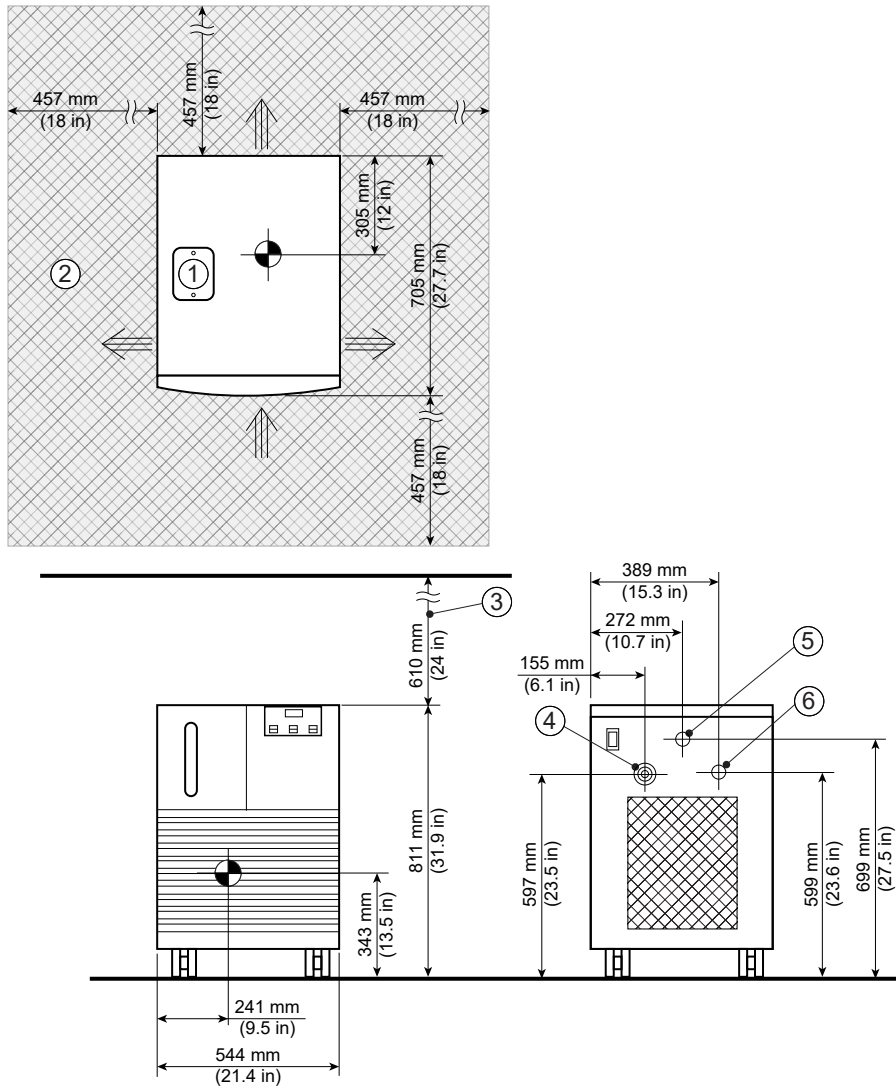

Item	Description	Item	Description
1	Reservoir access	4	Power connector
2	Air flow clearance and service access (see Note)	5	Coolant supply
3	Service access above unit	6	Coolant return



NOTE

Inadequate ventilation will cause a reduction in cooling capacity and, in extreme cases, compressor failure.

Servicing this unit may require movement of cabinet within air flow clearance area.

4.10 11kW Airsys Chiller (Outdoor)

Dry Weight (without coolant liquid): 315 kg (694 lb.)

Wet weight (with coolant liquid): 360 kg (804 lb.)

Magnetic field limit: 3 mT (30 G)

Figure 4-15 11kW Airsys Water Chiller Dimensions and Service Clearance for Single Unit

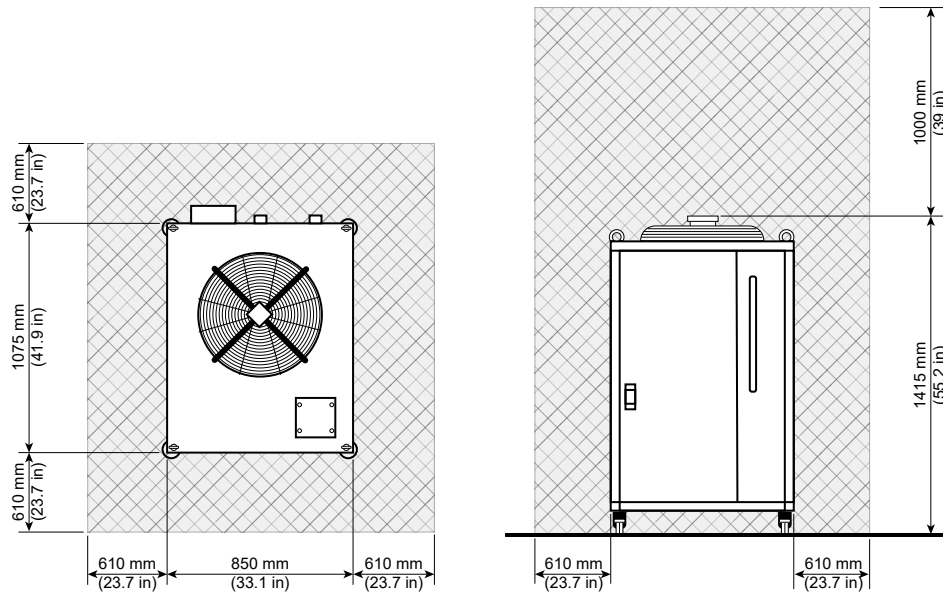

Figure 4-16 Service Clearances for Two or More Units, Option 1 (recommended)

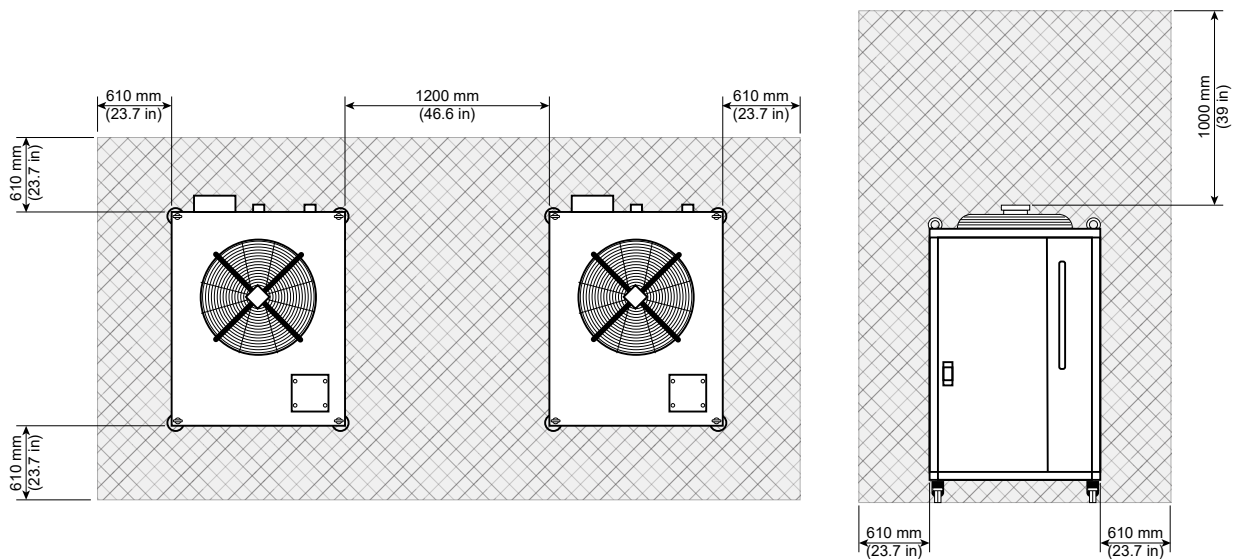

Figure 4-17 Service Clearances for Two or more Units, Option 2

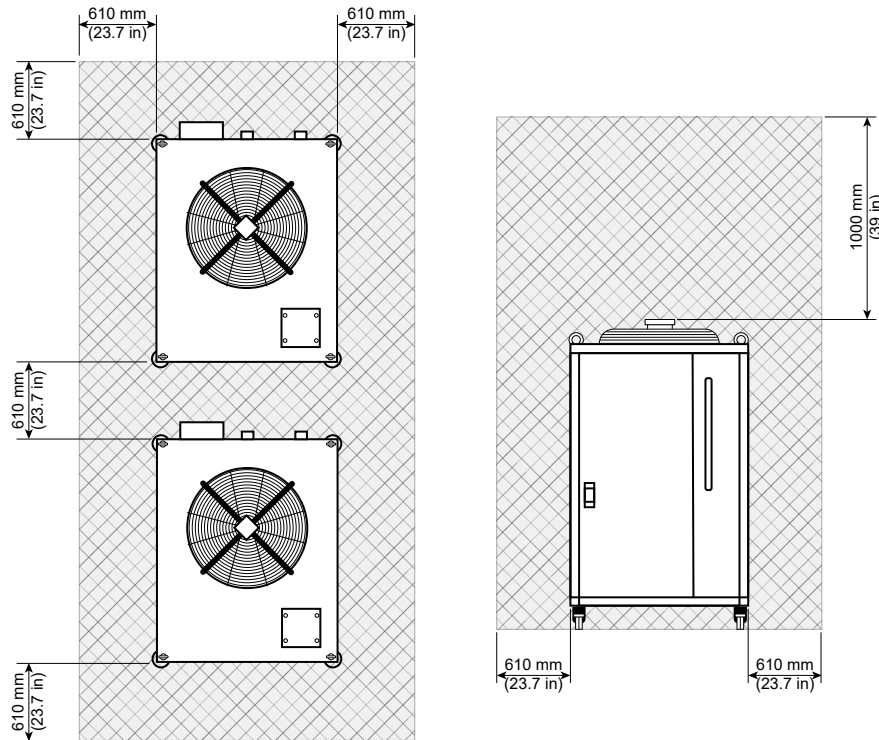
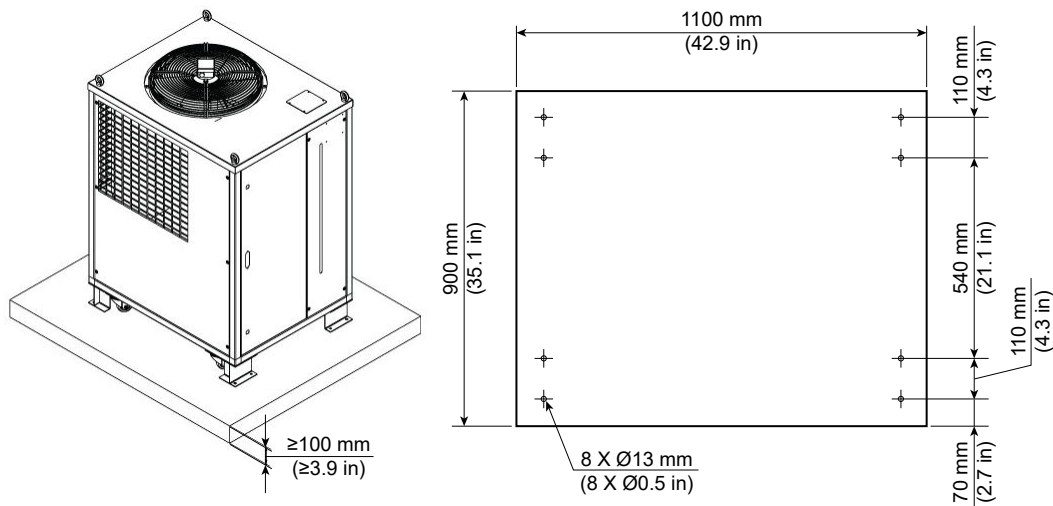

Figure 4-18 11kW Chiller Outdoor Mounting



Ground Installation

Loosen the bolts between the support brackets and the bottom of the crate, and mount the unit on the concrete pad.

Soil Requirements Below Concrete Pad

Soil below concrete pad used for mounting the unit must be flat and level within 10 mm (0.39 in) and be properly supported to prevent sedimentation. A concrete pad strength should be no less than 17.23 MPa (2500 psi).



NOTE

The concrete pad should meet or exceed the local code requirement.

Rooftop Installation

Loosen bolts between support brackets and bottom of crate and use the bracket to firmly fix the chiller on a level surface within 10 mm (0.39 in). Local code should be followed.



NOTE

In extreme weather conditions, such as a snowstorm, snow and ice can affect the correct operation of the fan. Thus, it is recommended to shelter the unit to protect the fan from extreme weather.

Be careful of the elevation requirements, -3000 mm (-118 in) < height < 30000 mm (1180 in), ensure no circumfluence of coolant to the system.

Figure 4-19 Remote Control Panel (RCP) For 11kW Chiller

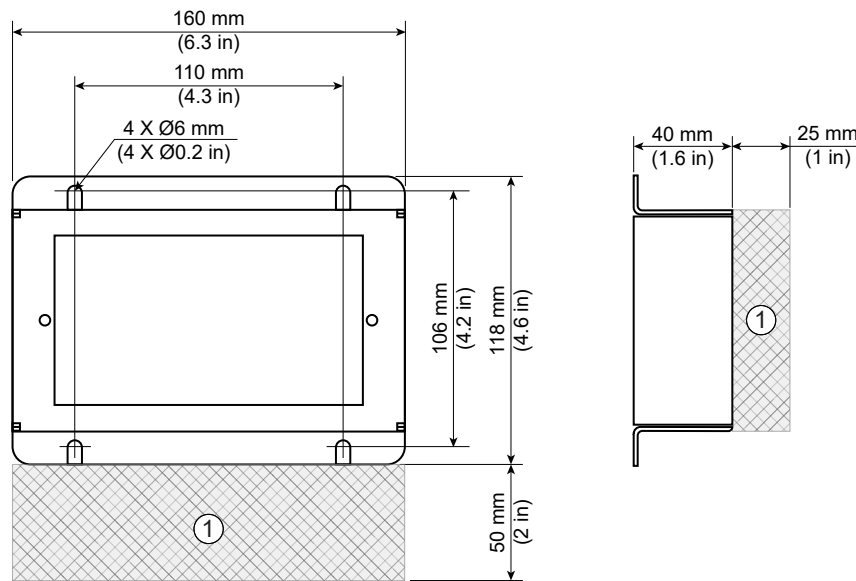

Item	Description
1	Service Area

4.11 Step Down Transformer (M3335TZ)

Weight: 160 kg (353 lb.)

Magnetic Field Limit: 5 mT (50 G)

Figure 4-20 Step Down Transformer

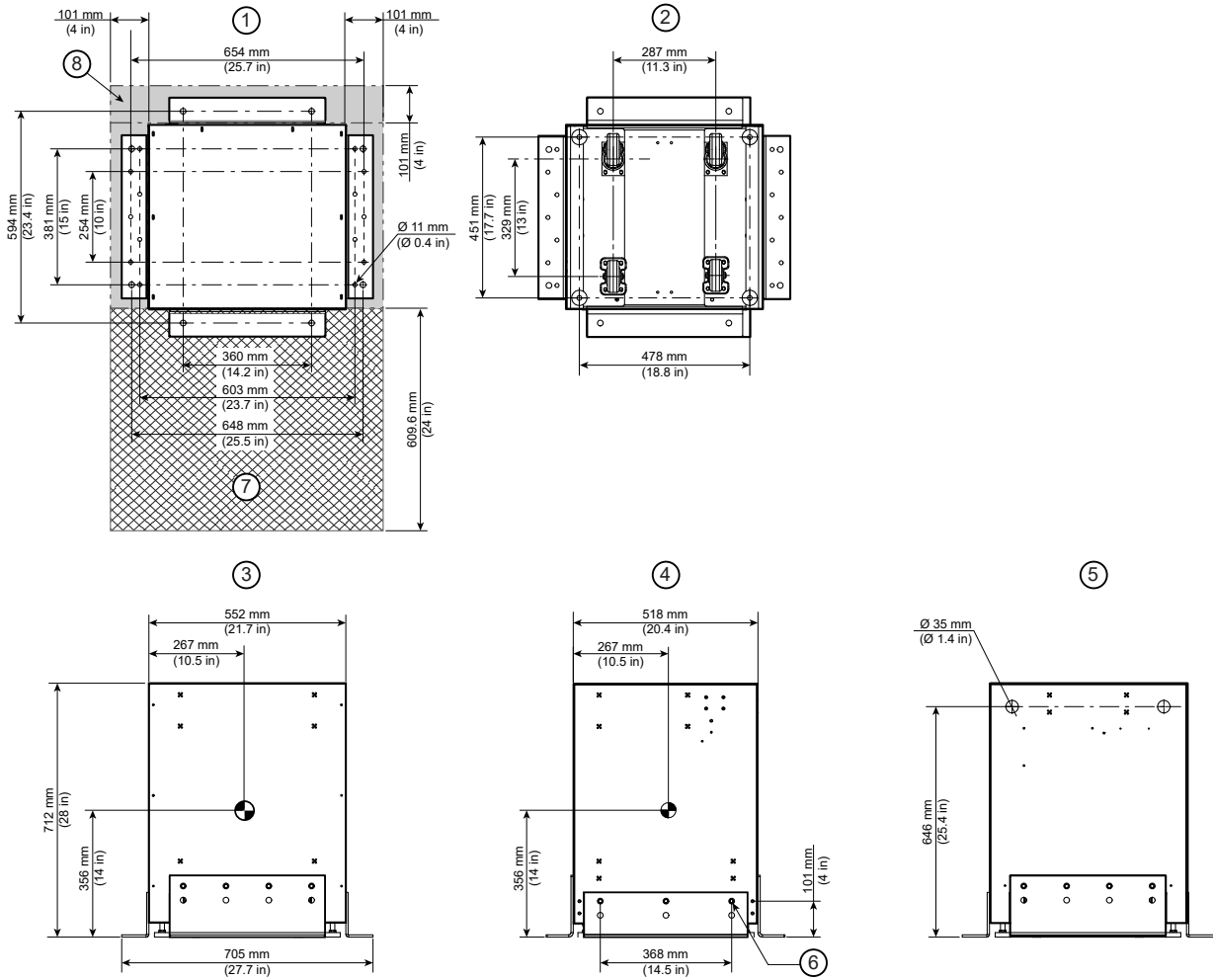

Item	Description	Item	Description
1	Top View	2	Bottom View
3	Front View	4	Right side View
5	Rear View	6	Seismic Anchor 6 * 3/8"-16 Suggested minimum torque 20 ft.lb. (For SAE Grade 2 bolts)
7	Service Area	8	Airflow clearance

4.12 Magnet Monitor (MON) Requirements and Specifications

4.12.1 Requirements

1. Customer must supply T100 network connection with RJ45 connector to the Magnet Monitor (MON). Network connectivity must be active prior to magnet delivery.
2. The cable must be Cat 5 or better.
3. The network connection must not be routed through the Ethernet switch in the Global Operator Cabinet (GOC).

4.12.2 Specifications

1. Mounting location: Wall installation in Equipment Room
2. Weight: 4.5 kg (10 lb.)
3. Magnetic Field Limit: 20 mT (200 gauss)
4. Power cord length: 1829 mm (72 in.)

Figure 4-21 Magnet Monitor (MON)

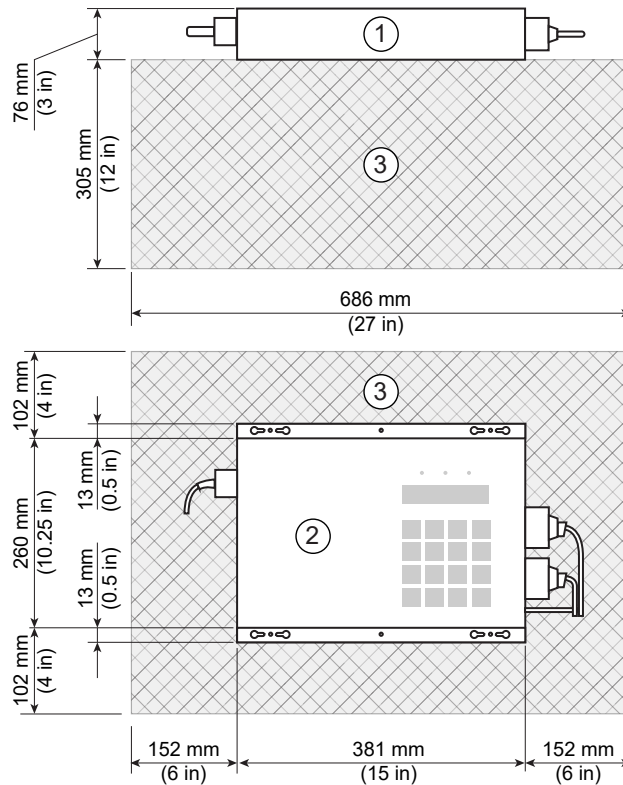

Item	Description	Item	Description
1	Top View	3	Service area
2	Front View	-	-

Figure 4-22 Magnet Monitor (MON) Mounting Patterns

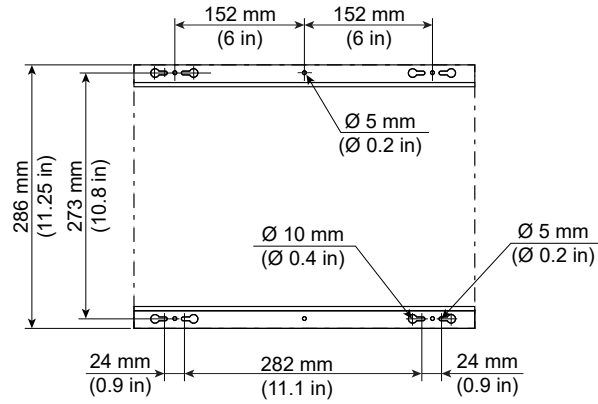

4.13 Magnetic Resonance Elastography (MRE) Specifications (Optional Equipment)

4.13.1 Requirements

1. The customer must work with the RF shield vendor to provide a waveguide for the 25 mm (1 in.) diameter tube.
2. MRE Resoundant Acoustic Driver location is limited to the length of the 25 mm (1 in.) tube (see the available cable lengths in [7.1.3 Magnetic Resonance Elastography \(MRE\) Option on page 150](#)).

4.13.2 Specifications

1. Weight: 24.22 kg (53.4 lb.)
2. Magnetic Field Limit: 5 mT (50 G)
3. Power Cord Length:
 - 60 Hz: 6096 mm (240 in.)
 - 50 Hz: 7620 mm (300 in.)

Figure 4-23 Magnetic Resonance Elastography (MRE) Resoundant Acoustic Driver

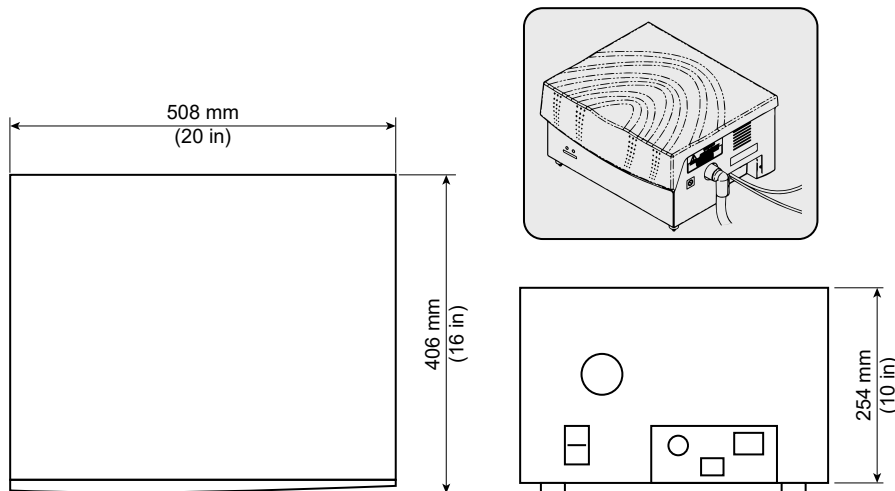

5 Control Room

5.1 Operator Workspace Equipment Specifications



(Applies to all sections within this chapter)

5.1.1 Operator Workspace Assembly

Figure 5-1 Operator Workspace Assembly

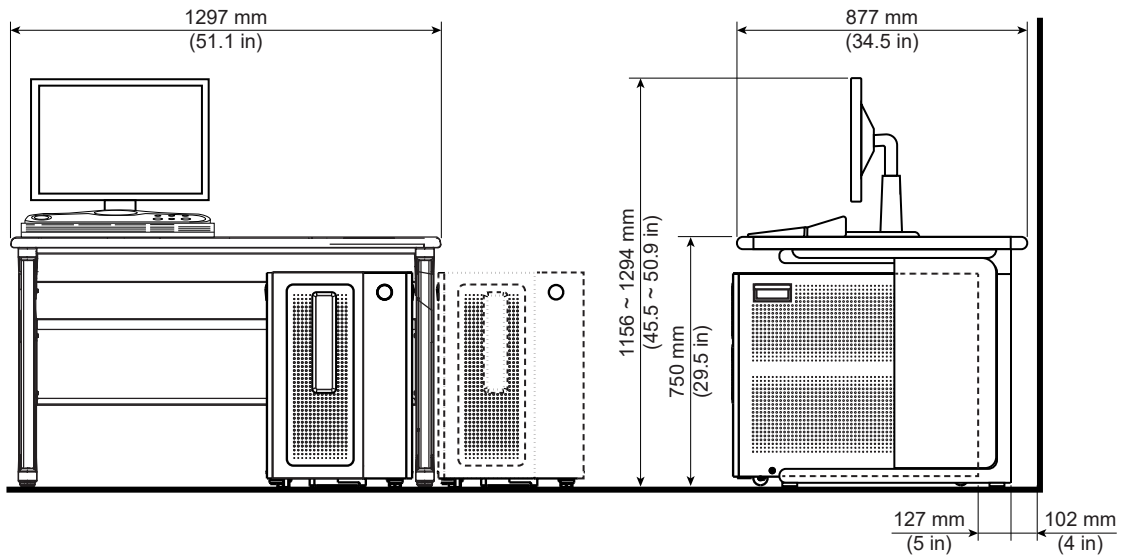

5.1.2 Operator Workspace (OW) (Optional Equipment)

1. Weight: 57 kg (125 lb.)
2. Magnetic Field Limit: 5 mT (50 G)

Figure 5-2 Operator Workspace (OW) Table (Top and Front View)

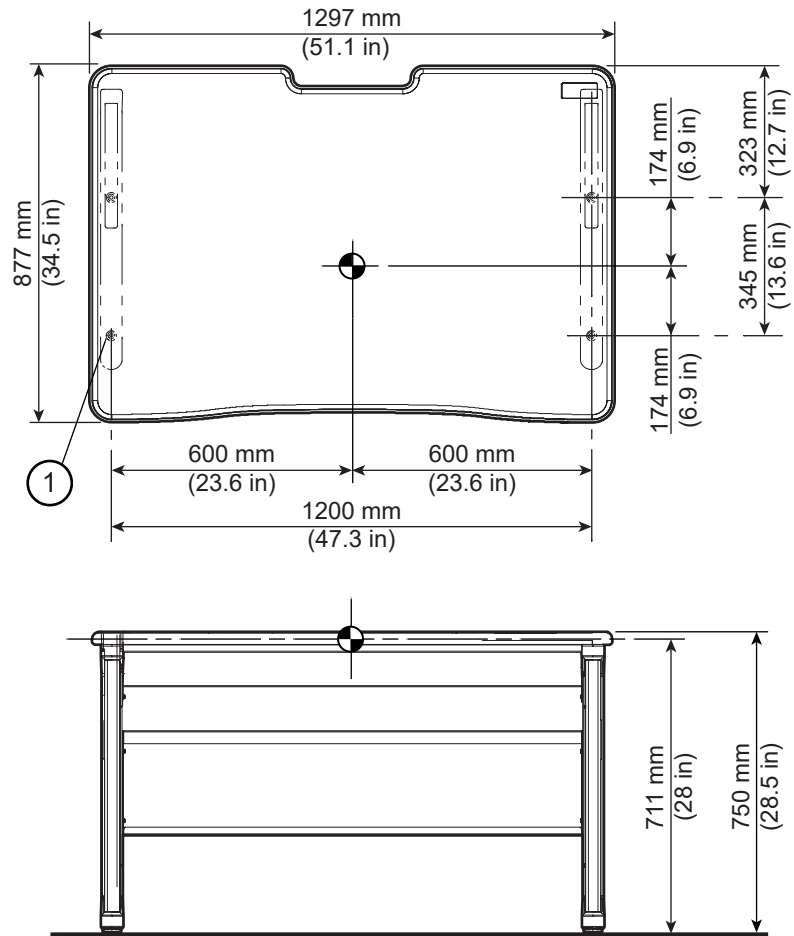

Item	Description
1	Four (4) 15.9 mm (5/8 in.) thru mounting holes for 9.5 mm (3/8 in.) seismic anchors

5.1.3 Global Operator Cabinet (GOC)

1. Weight:
 - For Dell T5820:** 57.4 kg (126.6 lb.)
 - For HP Z4G5:** 53.2 kg (121 lb.)
2. Magnetic Field Limit: 5 mT (50 G)
3. Anchor size: M10 (3/8 in.)

Figure 5-3 Global Operator Cabinet (GOC)

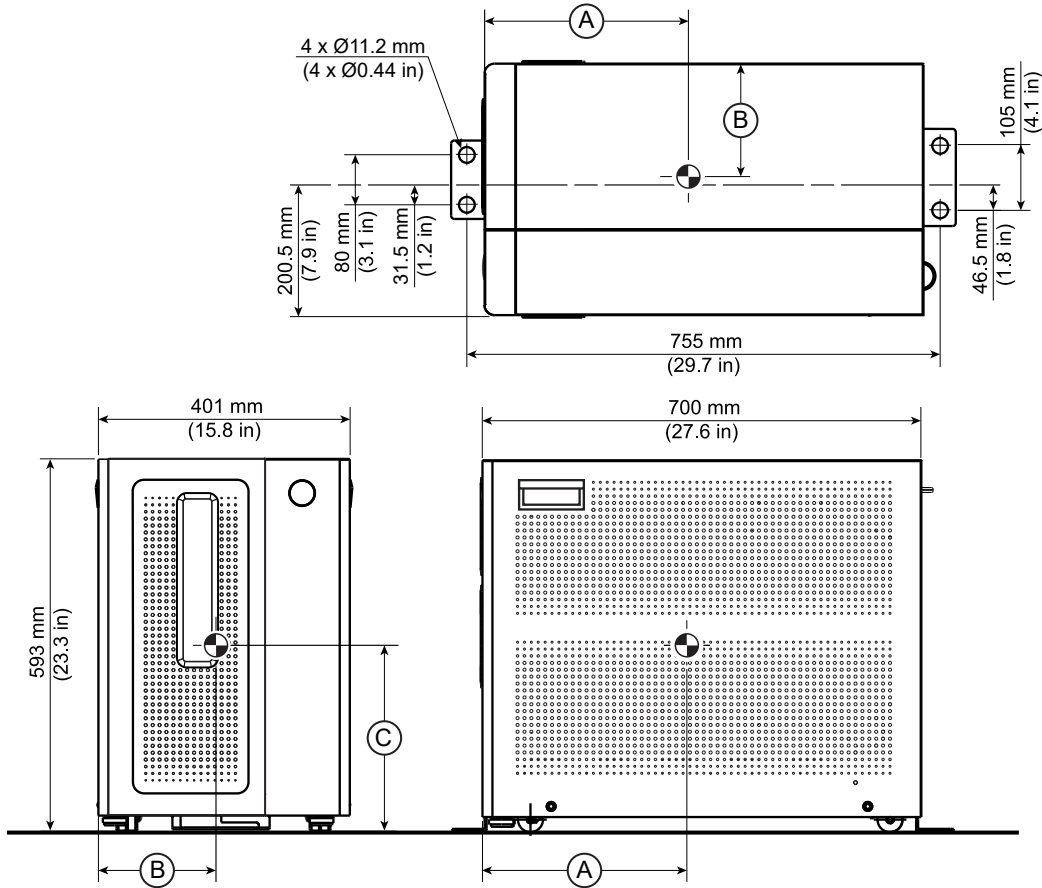

	A	B	C
Dell T5820	317 mm (12.5 in.)	194 mm (7.6 in.)	278 mm (10.9 in.)
HP Z4G5	370 mm (14.6 in.)	205 mm (8.1 in.)	330 mm (13 in.)

5.1.4 Host Display

Weight and dimensions for the Host Display are approximate and might vary depending on the display model.

1. Weight: 6.7kg (14.8 lb.)
2. Magnetic Field Limit: 5 mT (50 G)

Figure 5-4 Host Display

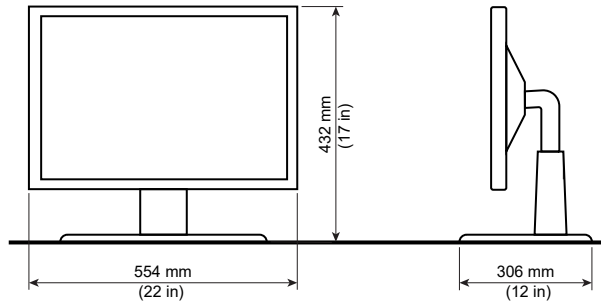

5.1.5 Host Keyboard

Figure 5-5 Host Keyboard

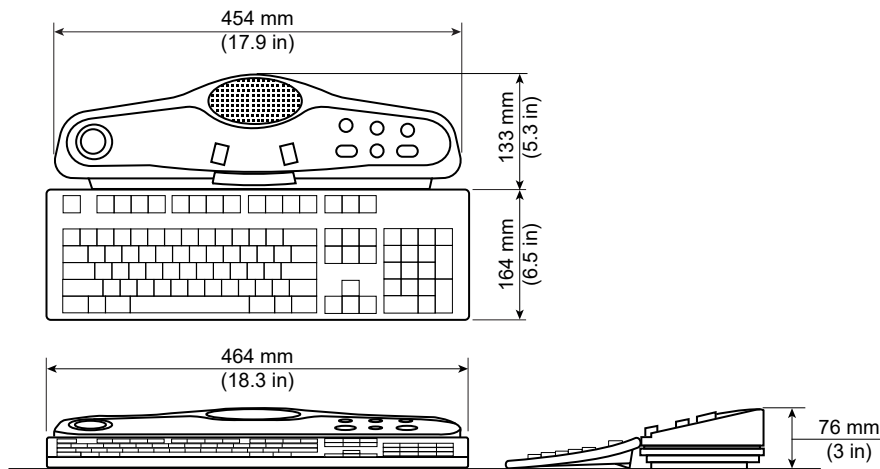

5.1.6 Pneumatic Patient Alert

The Pneumatic Patient Alert system allows the patient to contact the operator. The Control Box audible and visual alarm will be activated by the patient squeeze bulb which is located on the Magnet Enclosure and connected by pneumatic tubing through the Penetration Panel to the Control Box.

1. Weight 0.2 kg (0.5 lb.)
2. Magnetic Field Limit: 5 mT (50 G)
3. The Control Box must be placed or mounted within reach of the operator and within 1.5 m (5 ft.) of an electrical outlet.

Figure 5-6 Pneumatic Patient Alert (PA) with Mounting Pattern

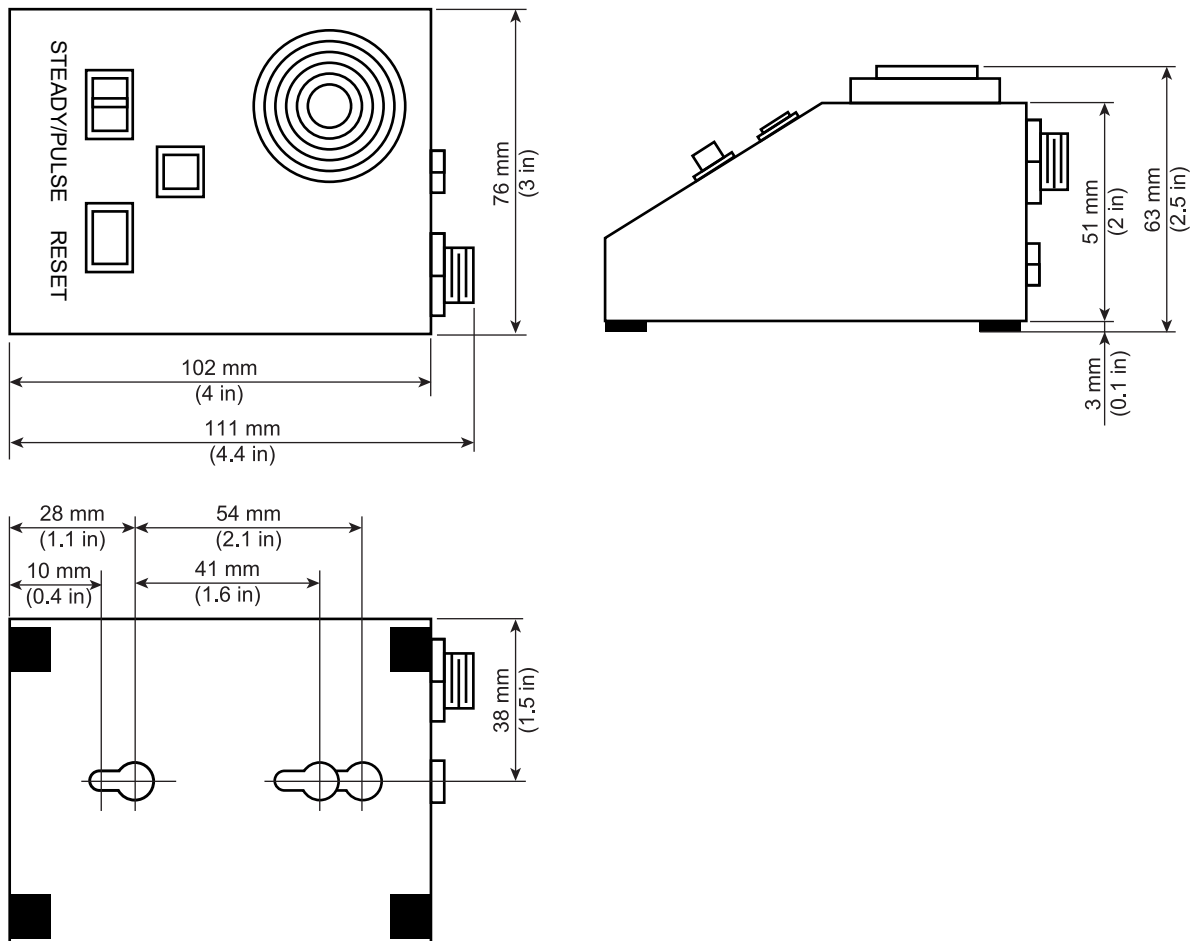

5.2 Oxygen Monitor (OXY) Specifications (Optional Equipment)

The optional Oxygen Monitor system consists of the Oxygen Monitor, the Remote Oxygen Sensor Module. The Oxygen Monitor alarm is located near the Operator Workspace is activated by the Remote Oxygen Sensor Module in the Magnet Room.

1. Oxygen Monitor Weight: 3.6 kg (8 lb.)
2. Oxygen Sensor Module Weight: 0.9 kg (2 lb.)
3. Magnetic Field Limit: 10 mT (100 G)

Figure 5-7 Oxygen Monitor and Remote Sensor

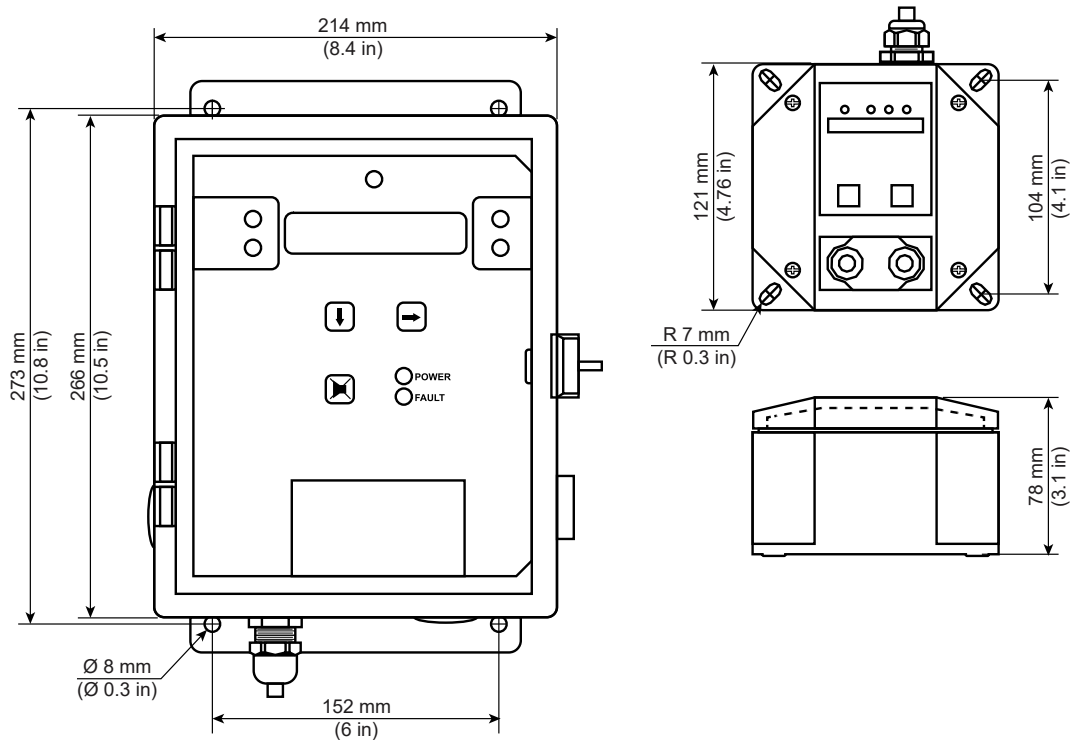

6 Digital Service and Connectivity Requirements

6.1 InSite RSvP (Remote Service Platform) Requirements

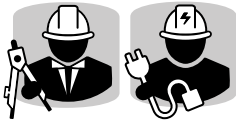

(Applies to all sections within this chapter)

6.1.1 InSite RSvP Connectivity Requirements

Following are the requirements for InSite RSvP connectivity:

1. The customer shall provide a physical connection or a route to an existing enterprise LAN.
2. The cable must be Cat 5 or better.
3. The customer shall provide outbound internet access for the device using HTTPS protocol over port 443.
4. The customer's network administrators shall provide DNS IP Address or Proxy IP address and authentication information (if applicable for the proxy server).
5. The customer's network administrators shall whitelist the following URLs:
 - Enterprise production:
 - <https://insite.gehealthcare.com:443>
 - <https://as1-insite.gehealthcare.com>
 - <https://as2-insite.gehealthcare.com>
 - Flexera URL: <https://gehealthcare-ns.flexnetoperations.com>
 - Flexera Software Download URL: <https://download.flexnetoperations.com>
 - For EU regions, whitelist the following:
 - <https://as1-insite-eu.gehealthcare.com>
 - <https://insite-eu.gehealthcare.com>

7 MR System Interconnects

7.1 MR System Interconnects Specifications



(Applies to all subsections within this section)

7.1.1 Component Designator Definitions

GE HealthCare uses Component Designators to identify system components. All subsystem cabinets and other components are referred to by their component designators in the Interconnect Data diagrams and tables.

Table 7-1 MR System Component Designators

Component Designator	Description
BB	Blower Box
BRMC	BRM Chiller
CRY	Cryocooler Compressor Cabinet
EO1/EO2	Emergency-Off (E-Off) Buttons
SC	System Cabinet
LCS4	4 kW LCS
LCS8	8 kW LCS
MAG	Magnet and Enclosure (all magnet enclosure components in the Magnet Room)
MDP	Main Disconnect Panel
MON	Magnet Monitor
MRU	Magnet Rundown Unit
OW	Operator Workstation
PA1	Pneumatic Patient Alert Control Box
PDU	Power Distribution Unit (PDU) is a module in the SC
PED	Magnet Rear Pedestal
PP	Penetration Panel
PT	Patient Transport Table
WC1	11kW Chiller 1
WC2	11kW Chiller 2

Table 7-2 MR System Options Component Designators

Component Designator	Description
MRE	Magnetic Resonance Elastography
OXY	Oxygen Monitor
OM2	Remote Oxygen Sensor Module

7.1.2 Available Cable Lengths

Two configurations of cable lengths are available for order. To determine required cable lengths, find the total distance of the cable path between the specified equipment by measuring the following:

- distance from the bottom of the specified equipment to the cable trough
- horizontal distance of the cable trough
- distance from the cable trough to the bottom of the other specified equipment

Compare the total distance to the lengths specified in [Table 7-3 Available Cable Lengths on page 143](#). If your distance is longer than the Usable cable length given in below list, you must reconfigure the layout of the room.

Table 7-3 Available Cable Lengths

Length Identifier (shown in the figure below)	Point A	Point B	Site Option: Short	Site Option: Long
			Usable cable length mm (in.)	
Magnet Room				
L1	ISC, bottom	BB	6000 (236)	13000 (512)
L3 (This length is for system cables.) For gradient cable available lengths, refer to Table 7-4 Available Cable Lengths for Gradient Cable on page 144	ISC, bottom	MAG, bottom back	7800 (307)	11500 (453)
L23	ISC, bottom	PED, bottom back	7000 (276)	12500 (492) ²
Not shown	PP, bottom	OM2	29400 (1157)	
L7	PP, bottom	MAG, bottom back	9800 (386)	
L24	PP, bottom	PED, bottom back	13300 (524)	
Not shown	PP, bottom	EO1	15800 (622)	25800 (1016)
Not shown	MAG, bottom back	MRU	29500 (1016)	
L22	BB	PED, bottom back	4880 (192) Flexible vinyl hose can be cut to length during installation.	
Equipment Room				
L2	ISC, top panel	RF Door Switch	29500 (1161)	
L4	ISC, top panel	OW	29000 (1142)	

Table 7-3 Available Cable Lengths (Table continued)

Length Identifier (shown in the figure below)	Point A	Point B	Site Option: Short	Site Option: Long
			Usable cable length mm (in.)	
L5	PP	OW	29000 (1142)	
L8	ISC, top panel	MON	17200 (477)	
L9	CRY	MON	17400 (685)	
L10	ISC, top panel	LCS8 (Type A, B, B') MCS (Type C, D, E)	9000 (354)	
Not shown	PP	OXY	26200 (1031)	
L12	PP	CRY	13800 (543)	
Not shown	PP	EO2	18600 (732)	
L17	LCS4	LCS8/MCS	3500 (138)	
L19	PP	MON	23000 (906)	
L20	CRY, bottom	MAG, bottom back	12000 (472) Flexible Helium Gas line routed through waveguides in PP	
L21	LCS4 (Type B, B') BRMC (Type D, E)	MAG, bottom back	17000 (669) Flexible water tubing routed through waveguides in PP	
Not shown	PA1	MAG, bottom back	30000 (1181) Pneumatic tubing, is routed from patient alert control box to magnet (via PAC/PAC Remote) through alert air line in PP.	
L25 ³	MDP	CRY power	7500 (295)	
Not shown	MON	Hospital ethernet switch	30000 (1181)	
Not shown	MON	Facility outlet for MON power	1827 (72)	

 **NOTE**

¹ Usable length: Cable length minus take up at each end.

² An additional 5000 mm (196.85 in.) is possible when RF extension cable M50002DF is ordered, for a total usable length of 17500 mm (689 in.).

³ A customer-supplied substitute can be used if the supplied run is shorter than required.

Table 7-4 Available Cable Lengths for Gradient Cable

Length Identifier (shown in the figure below)	Available lengths mm (in.)
L15	4800 (189)
	7800 (307)
	11500 (453)

Figure 7-1 Available Cable/Hose Lengths for Type A

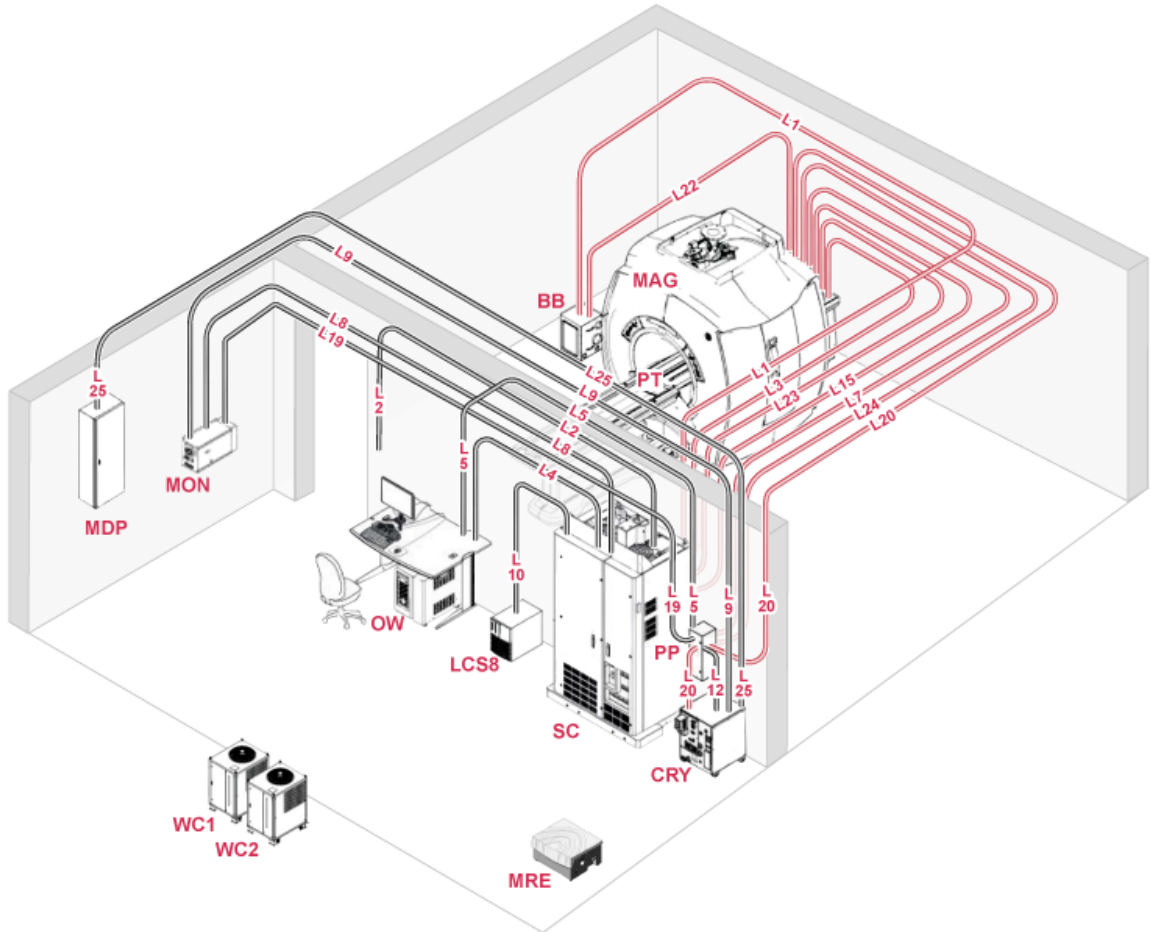

Figure 7-2 Available Cable/Hose Lengths for Type B

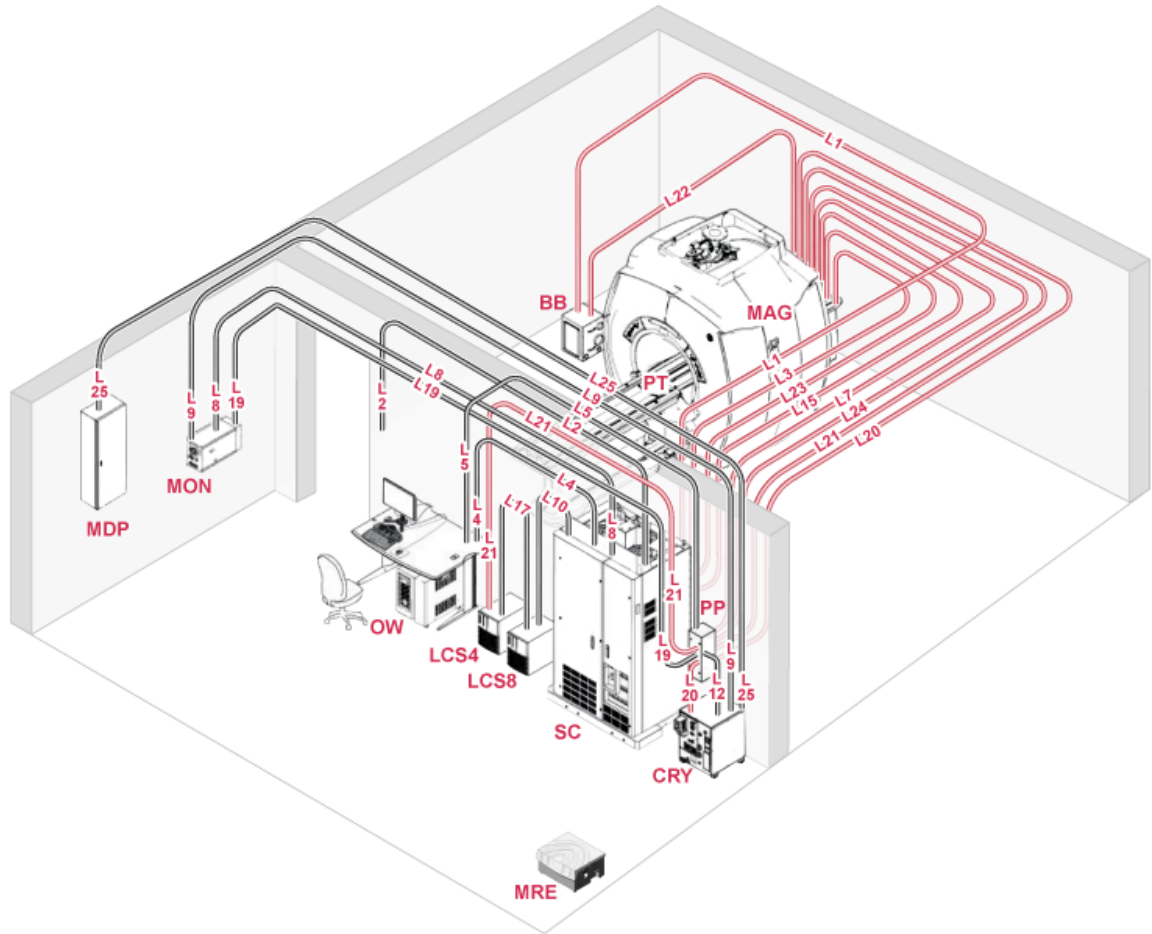
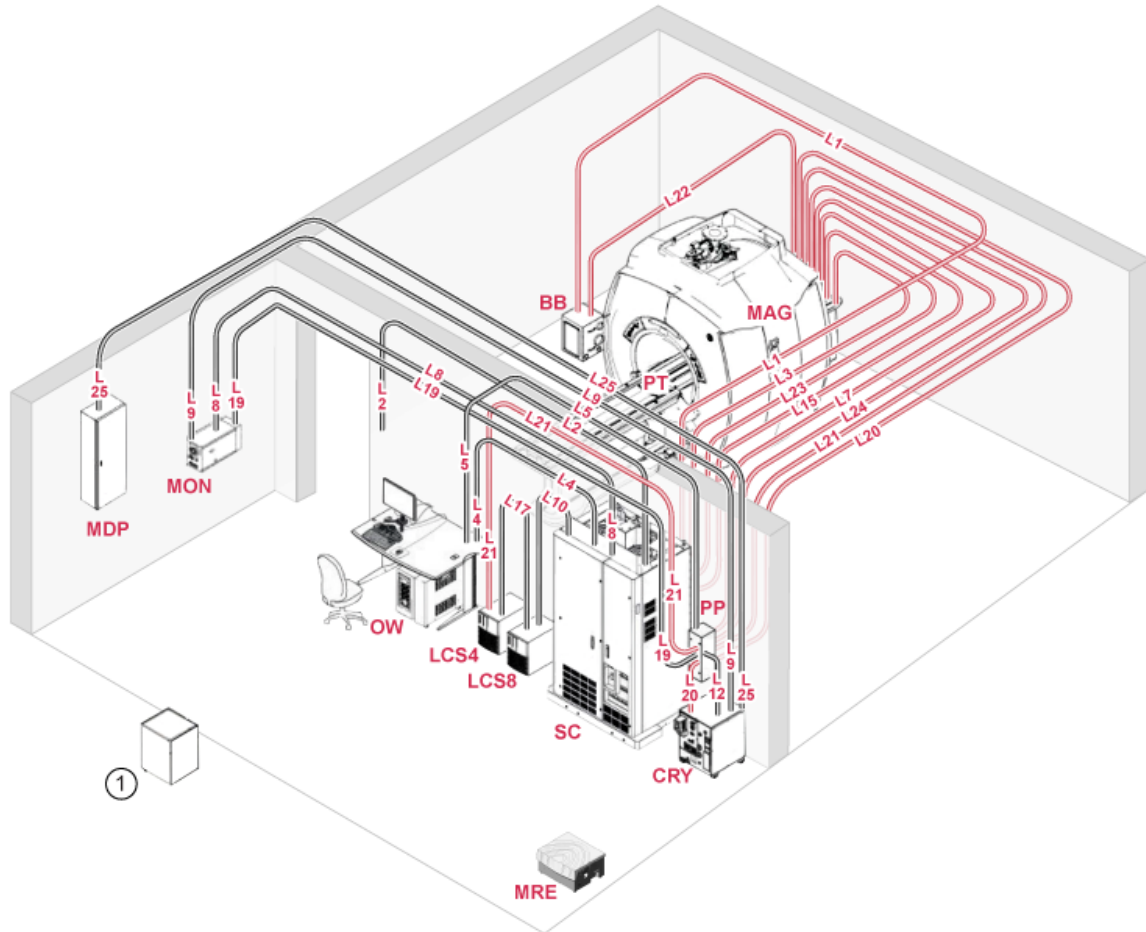

Figure 7-3 Available Cable/Hose Lengths for Type B'



Item	Description
1	Locally-Sourced Chiller

Figure 7-4 Available Cable/Hose Lengths for Type C

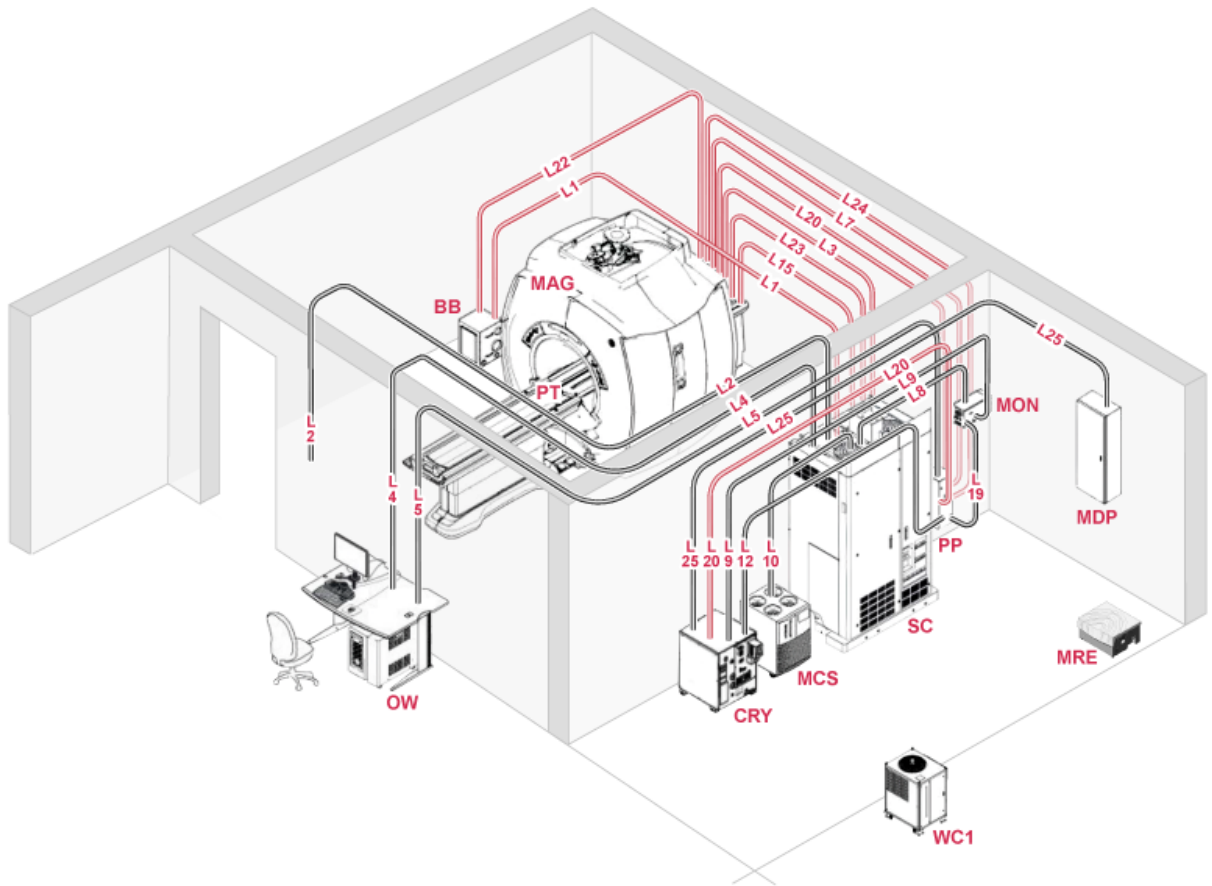

Figure 7-5 Available Cable/Hose Lengths for Type D

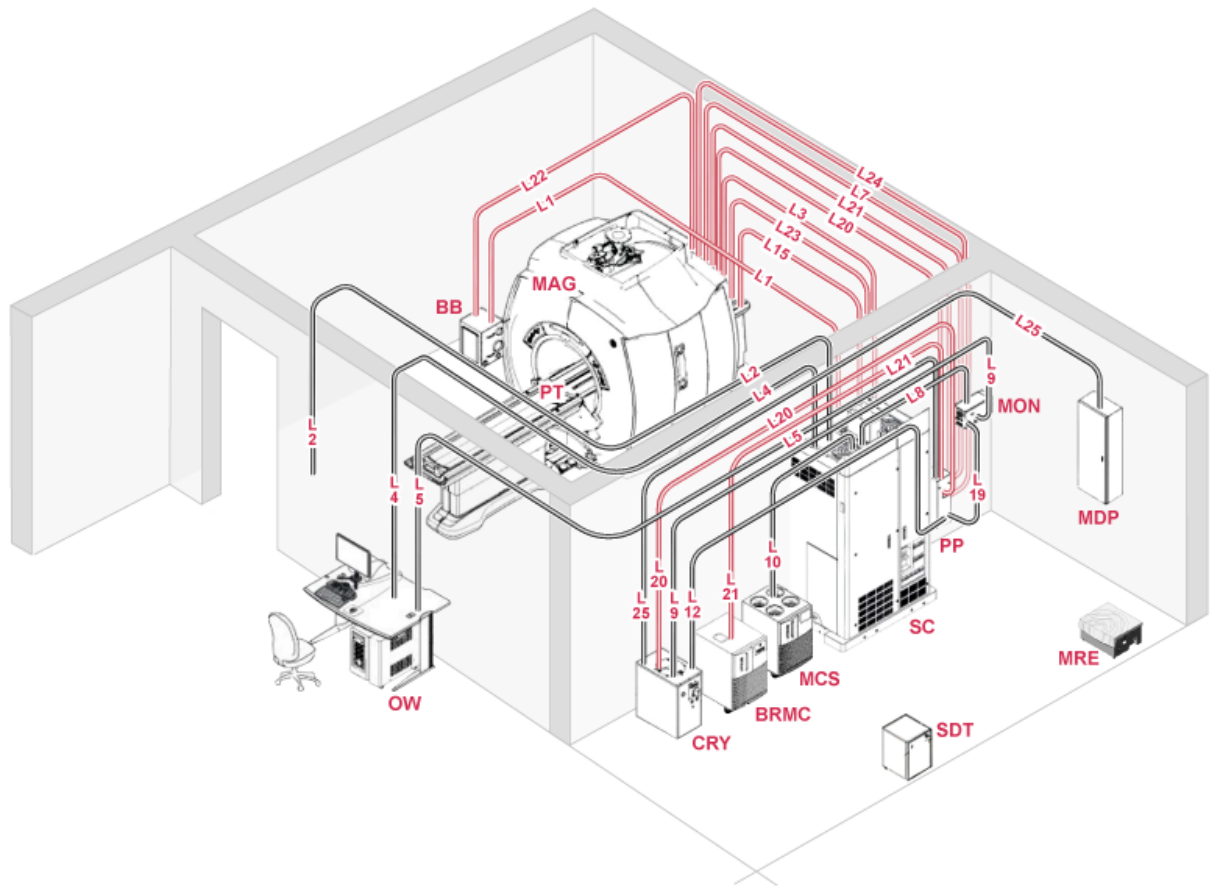
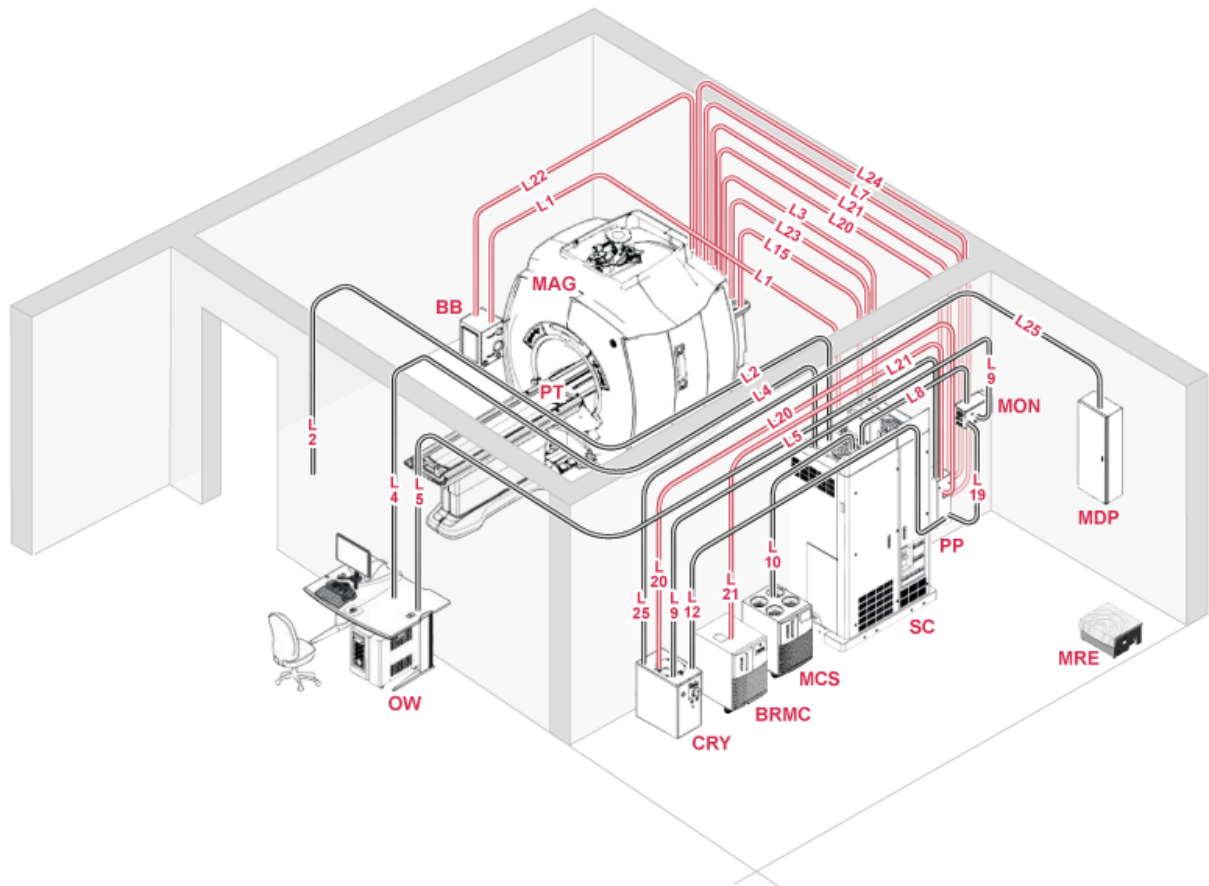

Figure 7-6 Available Cable/Hose Lengths for Type E



7.1.3 Magnetic Resonance Elastography (MRE) Option

Table 7-5 MRE Option Available Cable Lengths

Cable	Point A	Point B	mm (in.)
25 mm (1 in.) Tubing	Resonant Active Driver	Magnet (Isocenter)	Nominal 7315 (288) Maximum 10058 (396)
BNC	Resonant Active Driver	ISC	15240 (600)
Ethernet	Resonant Active Driver	Ethernet Hub in ISC	15240 (600)
Power	Resonant Active Driver	Customer-Supplied Outlet	60 Hz: 6096 (240) 50 Hz: 7620 (300)

7.2 MR System Interconnects Routing Requirements



(Applies to all subsections within this section)

7.2.1 Cabling Requirements

1. The customer is responsible for the purchase and installation of all cable support mechanisms.



NOTE

The cable support in the Magnet Room is a pit or duct. A recommended duct example in the Magnet Room is shown in [Figure 3-8 Duct or Pit Top View on page 94](#).

2. Any Magnet Room duct must attach to the RF Shield Room and the installation and routing of the duct or pit must be coordinated with the RF shield vendor.
3. Any type of nonferrous duct, such as composites or aluminum, may be used provided it meets all MR System requirements and any local and national codes.
4. All cables must enter the back of the magnet along the Z-axis (the Z-axis runs parallel to the patient table and the bore of the magnet).
5. The magnet-end subsection of the duct routing the gradient cables must be aligned to the center of the magnet (when viewed from the top).
6. Cables must be accessible for maintenance at all points along the route.
7. The duct or pit must accommodate a minimum cable bend radius of 435 mm (17.12 in.).
8. Gradient cables, signal cables, receiver (RX) cables, and Tx cables will be physically separated from one another along the route to minimize electrical noise coupling.

Figure 7-7 Cable Groups

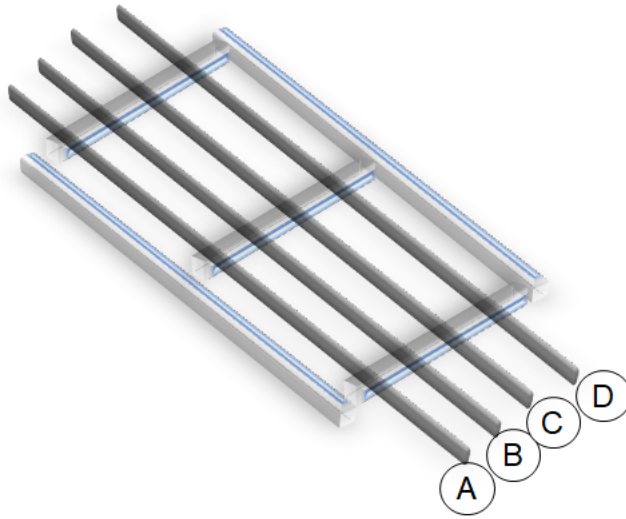

Item	Description	Item	Description
A	Gradient Cables	C	Receiver (RX) Cables
B	Signal Cables	D	Transmit (TX) Cables

9. All electrical and mechanical connections and fasteners must be tightened and secured to supplier specifications to prevent broadband interference
10. Excess cable length in the equipment must be stored in the Equipment Room.
11. Excess cable length in the Magnet Room must be stored in the pit or duct.

7.3 Facility-Supplied System Interconnects Specifications



On installation sites in China, make sure that the power cables and ground cables provided by customers have China Compulsory Certification (CCC). This information is supplied to the customer in China Power Cable Requirements, 5159493. (Go to the Customer Documentation Portal or contact the PMI.)

The following table lists the required facility-supplied system interconnects. Refer to [Figure 7-8 Facility-Supplied System Interconnects](#) on page 154 for additional information.

Table 7-6 Customer-Supplied Interconnects

Group	Between Units		Comments	Requirements
	From	To		
C01	Facility Power ¹	MDP		2.10 MR Suite Electrical Requirements on page 61
	Facility Emergency Power Filter	PP	Customer-supplied Ground	2.10 MR Suite Electrical Requirements on page 61
C02	MDP	CRY	CRY Power	2.10 MR Suite Electrical Requirements on page 61
C03	MDP	PDU		2.10 MR Suite Electrical Requirements on page 61
	MDP	EO2		2.10 MR Suite Electrical Requirements on page 61
	Facility Power	Filter		2.10 MR Suite Electrical Requirements on page 61
	Filter	MRU		2.10 MR Suite Electrical Requirements on page 61
	Facility Power	OXY		2.10 MR Suite Electrical Requirements on page 61
C04	Facility Network	MON	Facility must provide network access for the Magnet Monitor (MON). The MON connection must be available at all times.	4.12 Magnet Monitor (MON) Requirements and Specifications on page 132
	Facility Network	GOC	Facility must provide network access for Global Operator Cabinet (GOC).	6.1 InSite RSVP (Remote Service Platform) Requirements on page 141
	Facility Network	Receptacle near MDP		4.2 Main Disconnect Panel (MDP) Requirements and Specifications on page 116
C05	MDP	E-off Switch	Facility must supply cable from the MDP to the E-off Switch in the Equipment Room.	2.10 MR Suite Electrical Requirements on page 61

Table 7-6 Customer-Supplied Interconnects (Table continued)

Group	Between Units		Comments	Requirements
	From	To		
C06	PP	E-off Switch in Control Room or Magnet Room	Facility must supply additional wiring between the GE-supplied cable and the E-off switch if the length needed is greater than the available length listed in 7.1 MR System Interconnects Specifications on page 142	2.10 MR Suite Electrical Requirements on page 61
	MDP	11 kW Chiller	For Type A Configuration, prepare cables for two 11 kW Chillers. For Type C Configuration, prepare cables for one 11 kW Chiller.	2.10 MR Suite Electrical Requirements on page 61
	MDP	Lytron BRM Chiller	This cable is for Type D, E configuration.	2.10 MR Suite Electrical Requirements on page 61

Notes:

- If low Voltage Step-Up Transformer Option (R4500AW or R4500BE) is used then customer-supplied interconnects are required between facility power, transformer and MDP.

Figure 7-8 Facility-Supplied System Interconnects

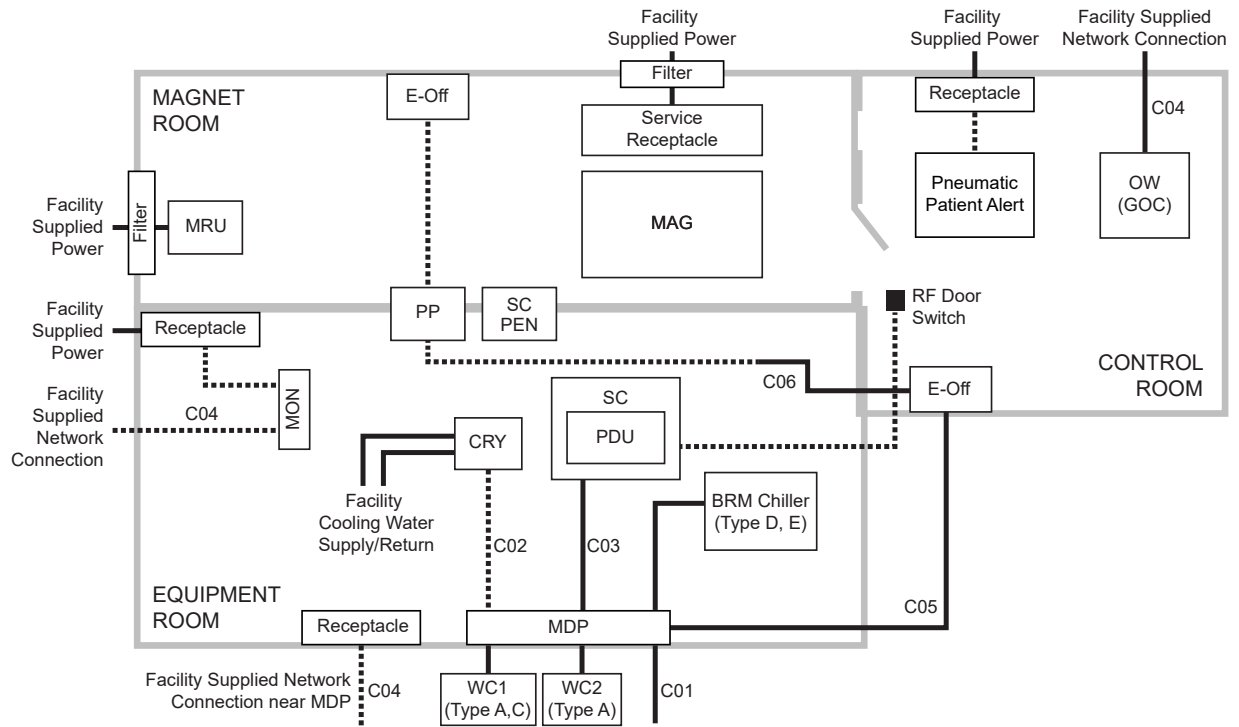

Legend			
	Facility supplied interconnect		GE HealthCare supplied interconnect

**NOTE**

- GE HealthCare recommends installing the RF Door switch on the outside wall of the Magnet Room.
- The illustration is not to scale and component positioning/interconnect runs are typical.
- Only GE HealthCare equipment interconnects are shown. Additional facility interconnects are required for non-GE HealthCare equipment (for example, Magnet Room DC Lighting).
- The E-Off button placement and cable routing shown indicates one possible configuration. Final E-Off button placement and cable routing is the responsibility of the customer. Refer to [2.10.1 General Electrical Requirements on page 61](#) for requirements for E-Off button placement.

The RF Shielded Room Vendor is responsible for installing the RF door switches. Refer to *RF Shielded Room Requirements, 5850260-1EN*.

8 Appendix

8.1 Glossary



Cryogen

A substance for producing low temperatures. Liquid helium is the cryogen used to cool the magnet to approximately 4 K (-269°C or -452°F).

Dewar

A container with an evacuated space between two highly reflective walls used to keep low temperature substances at near-constant temperatures. Liquid helium is usually stored and shipped in dewars.

Ferrous Material

Any substance containing iron which is strongly attracted by a magnetic field.

Gauss (G)

A unit of magnetic flux density. The earth's magnetic field strength is approximately one half Gauss to one Gauss depending on location. The internationally accepted unit is the tesla (1 tesla = 10000 G and 1 millitesla = 10 G).

Homogeneity

Uniformity. The homogeneity of the static magnetic field is an important quality of the magnet.

Isocenter

Center of the imaging volume ideally located at the magnet center.

Isogauss Line

A line on a field plot connecting identical magnetic field strength points.

Magnetic Field

A condition in a region of space established by the presence of a magnet and characterized by the presence of a detectable magnetic force at every point in the region. A magnetic field exists in the space around a magnet (or current carrying conductor) and can produce a magnetizing force on a body within it.

Magnetic Resonance (MR)

The absorption or emission of electromagnetic energy by nuclei in a static magnetic field, after excitation by a suitable radio frequency field.

Magnetic Shielding

Using material (for example, steel) to redistribute a magnetic field, usually to reduce fringe fields.

Quench

Condition when a superconducting magnet becomes resistive thus rapidly boiling off liquid helium. The magnetic field reduces rapidly after a quench.

Radio Frequency (RF)

Frequency intermediate between audio frequency and infrared frequencies. Used in magnetic resonance systems to excite nuclei.

Radio Frequency Shielding

Using material (for example, copper, aluminum, or steel) to reduce interference from external radio frequencies. A radio frequency shielded room usually encloses the entire Magnet Room.

Resonance

A large amplitude vibration caused by a relative small periodic stimulus of the same or nearly the same period as the natural vibration period of the system. In magnetic resonance imaging, the radio frequency pulses are the periodic stimuli which are at the same vibration period as the hydrogen nuclei being imaged.

Superconducting Magnet

A magnet whose magnetic field originates from current flowing through a superconductor. Such a magnet is enclosed in a cryostat.

Superconductor

A substance whose electrical resistance essentially disappears at temperatures near zero Kelvin. A commonly used superconductor in magnetic resonance imaging system magnets is niobium-titanium embedded in a copper matrix.

Tesla

The internationally accepted unit of magnetic flux density. One tesla is equal to 10000 Gauss. One millitesla is equal to 10 Gauss.

Waveguide

A hollow linear structure used in components such as the penetration wall to route cables and hoses, while limiting and controlling electromagnetic waves from entering the Magnet Room.

8.2 MR Site Vibration Test Guidelines



(Applies to all subsections within this section)

8.2.1 Test Measurements

1. Vibration measurements must be in the range of 10^{-6} g. Test equipment must have the required sensitivity to these levels.
2. Instrumentation must have a low tolerance to temperature effects since many times the low frequency thermal drift may influence the measurements.
3. All measured data must be acquired real time. Recording of vibration data will not allow for a correct site survey, specifically when studying transient vibration and when searching for specific vibration sources.
4. All analyses must be narrow-band Fast Fourier Transforms (FFT) over the frequency bands listed in [Table 8-1 Frequency Bands for FFT on page 158](#).
5. Time histories of the vibration must be recorded as acceleration levels vs. time. The resolution of the time history must be adjusted to clearly capture the transient event. The analyzer set-up will be site dependent and, in special cases, vibration response dependent. It is the responsibility of the vibration consultant to study the transient environment, capture data to confirm that transient activity exceeds the trigger level, then expand the time history data to exhibit the structural response.

Table 8-1 Frequency Bands for FFT

Frequency Band	Frequency Resolution
0.2 to 50 Hz	$\Delta f = 0.125$ Hz

8.2.2 Equipment (Spectral Analyzer) Set-Up

1. Frequency average should be a minimum of 20 linear averages (Do not use peak hold or 1/3 octave analysis).
2. Average and store should be a minimum of 20 plots steady state and 20 plots transient to support the consistency of the site vibrations.
3. Hanning windows must be applied to the entire spectra.
4. Spectrum analyzers capable of these measurements are readily available for purchase or rental. Models, such as the HP 3560A, Nicolet Phaszer, B&K Pulse, and HP 35670, are all capable of making the site vibration measurements. Accelerometers must have the capability to measure from 0.2 Hz beyond 50 Hz. Time histories can be recorded using any of the analyzers listed above.



NOTE

The equipment mentioned is for example only. It is the responsibility of the Engineering Test Firm to provide equipment that will allow measurements compliant with this guideline.

8.2.3 Data Collection

8.2.3.1 Ambient Baseline Condition

1. All of the measurements listed above must be made in a “quiet” environment—that is, areas where excessive traffic, subway trains, and so on, do not exist. A vibration measurement must also be made during periods without traffic or during periods of light traffic. Measurements must define the lowest levels of vibration possible at the site.
2. The source of any steady state vibration, whose level exceeds the magnet specifications found in [Magnet Room Structural Requirements on page 85](#), must be identified. A second measurement should be made with all of the identified contributors powered down if possible. In situations where it is not possible to power down equipment, vibration data must be collected to identify the specific source of the vibration concern. The majority of steady state vibration problems can be negated by isolating the vibration source.

8.2.3.2 Normal Condition

1. All of the vibration measurements listed above must be repeated during periods of “normal” environmental conditions, including the Fast Fourier Transforms (FFTs) and time histories. The transient measurements must be provided to define the dynamic disturbances the MR System may be exposed to. Transient analysis is required for a true assessment of the site.
2. Special attention must be paid to the site assessment during the entire analysis. Since transient vibration is not easily addressed once the MR suite is fully constructed, the test consultant must fully understand the needs for this analysis. The source of any transient vibration must be identified and supported with vibration plots. If the source of any transient vibration is not locatable, it is recommended that the customer have an alternate location identified and the vibration studied.
3. Transient vibration can be difficult to assess if the details are not understood. The **0.0005 g, zero-to-peak trigger level** is a starting point to understanding the vibration stability. The transient vibration peak amplitude, structural (time variant) response, decay rate and an estimate of the number of events per unit of time would constitute a complete transient analysis. All transient failures must be supported by time history plots. The plots must clearly show the structural response, the frequency of the signature and the decay rate. From this data, GE HealthCare can help determine compliance with the vibration guidelines.
4. The test consultant must provide site data to show the design recommendations for all sites/building structures meet the magnet specifications found in [Magnet Room Structural Requirements on page 85](#).

8.2.4 Presentation/Interpretation of Results

1. The recommended format for site vibration data collection, presentation, and analysis is demonstrated in the examples in [Figure 8-1 Example of Site Environmental Vibration Levels on page 160](#), [Figure 8-3 Acceleration Time History on page 161](#), and [Figure 8-4 Acceleration Time History \(Zoomed In on Transient Event\) on page 162](#). Presentation of the data in any other format (linear units only) may result in incorrect interpretation and diagnosis of the site. Additional data collection or presentation methods are at the option of the vibration testing service.
2. All plots must be properly annotated with:

- 2.1. Instrumentation setup including number of averages, frequency resolution, and so on
- 2.2. Test location
- 2.3. Test conditions:
 - 2.3.1. Steady state
 - 2.3.2. Transient
 - 2.3.3. Heel drop
 - 2.3.4. Normal environment
 - 2.3.5. Typical traffic
 - 2.3.6. Any other conditions necessary to demonstrate understanding of potential sources of vibration
3. The customer's vibration testing service is responsible for interpreting the results and determining if that site meets GE HealthCare specifications.
4. If the vibration levels are too high, additional data acquisition may be necessary to:
 - 4.1. Determine the source of the vibration
 - 4.2. Propose a solution to the problem
 - 4.3. Find an alternate site location
5. Any questions regarding test equipment requirements, test parameters, or general questions should be discussed with the GE HealthCare Project Manager of Installation (PMI).

Figure 8-1 Example of Site Environmental Vibration Levels

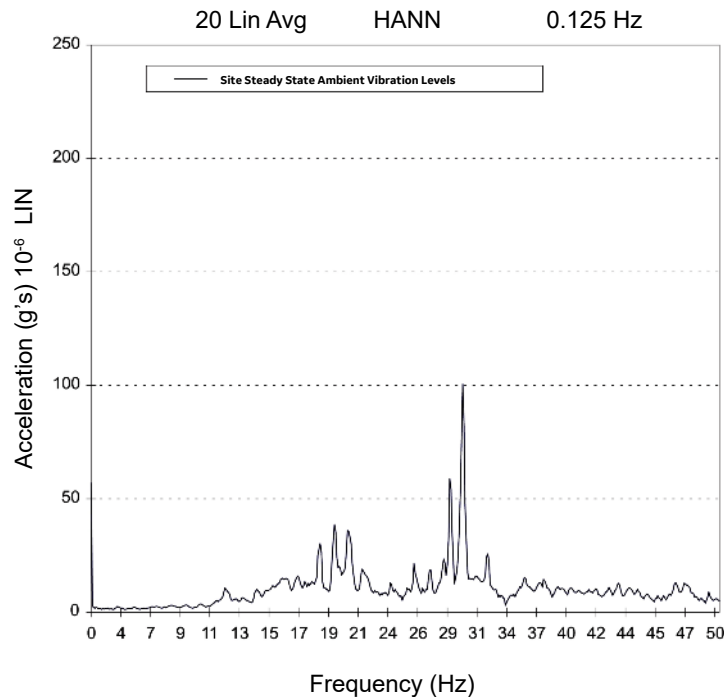

Figure 8-2 Example Site Environmental Vibration for RD Series Magnet

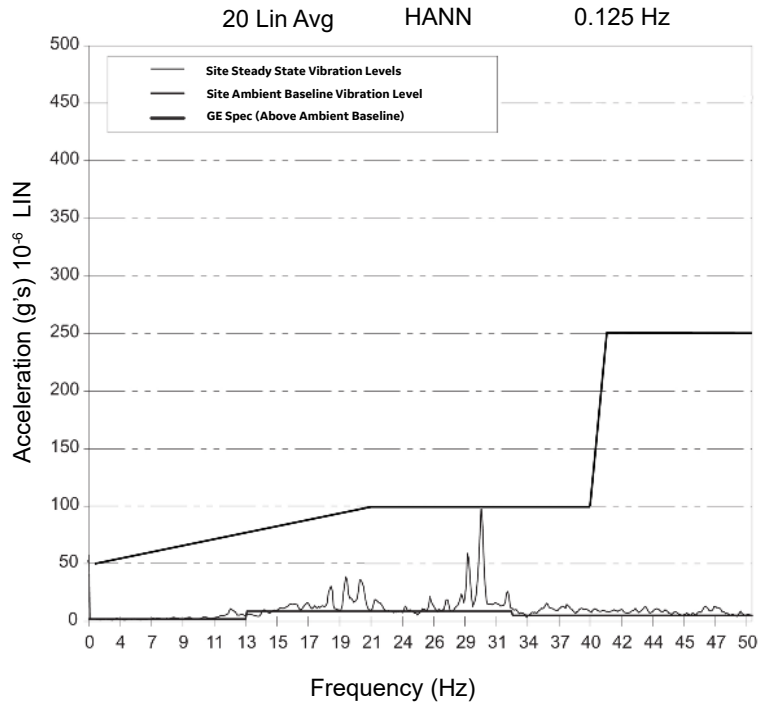

Figure 8-3 Acceleration Time History

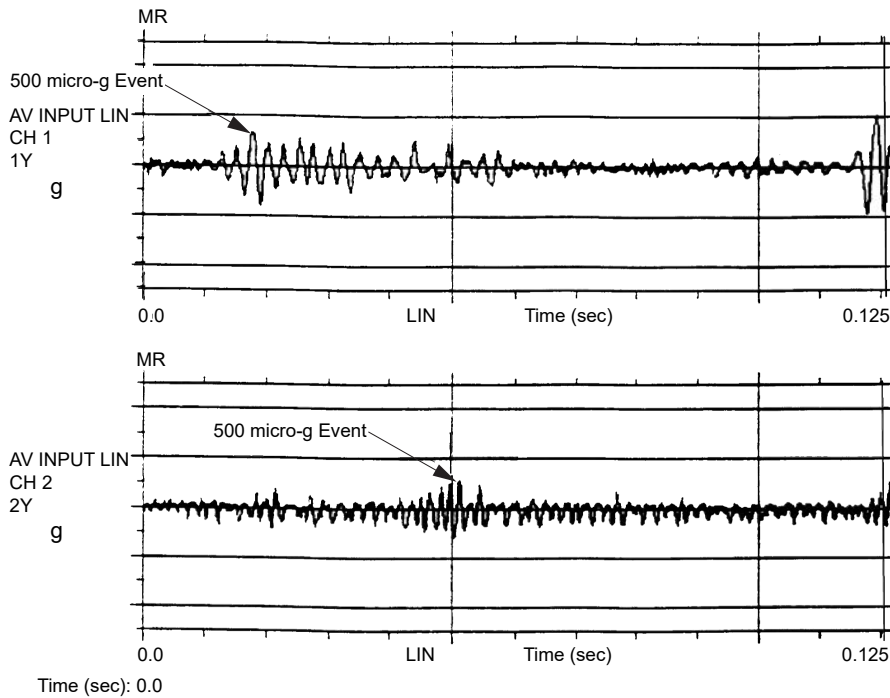
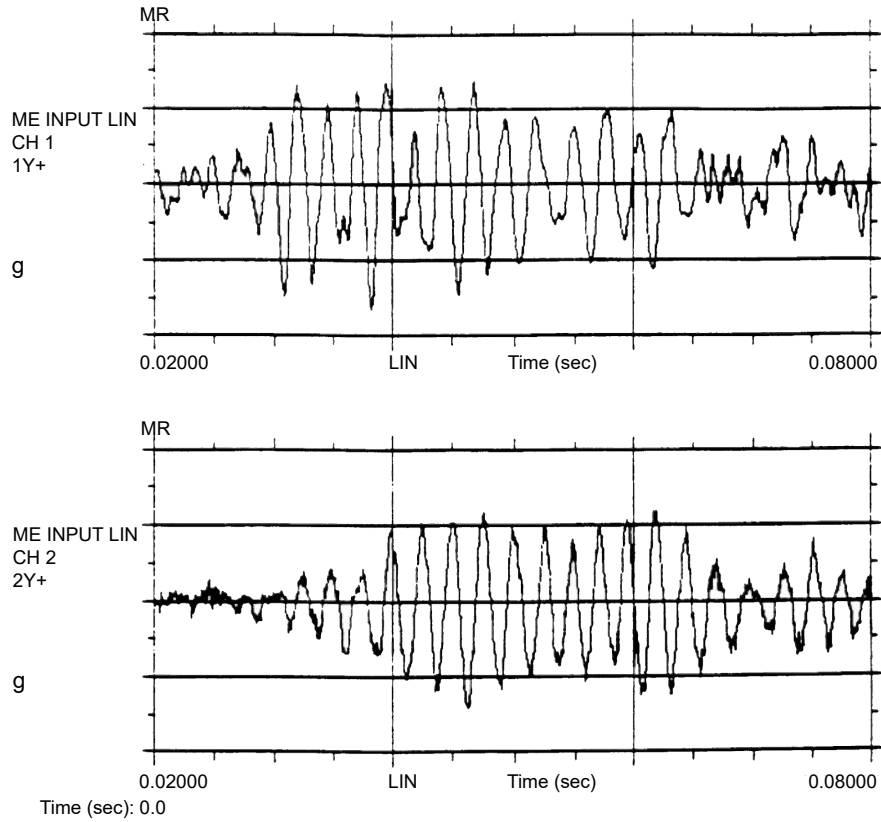

Figure 8-4 Acceleration Time History (Zoomed In on Transient Event)



8.3 Sample Calculation AC Power Equipment Minimum Distance



This is a sample calculation to determine minimum distance from a feeder, transformer, or other AC electrical source, using the formula found in 2.6.3 Electrical Current on page 35 to determine minimum distance from a feeder, transformer, or other AC electrical source.

$$I \text{ (amps)} = 20x^2 \text{ (meters)} \div S \text{ (meters)}$$

Note that the formula has three variables. If you have two of them, you can calculate the third. In this example, we calculate the minimum distance **x** from the source—in this case, a main electrical feeder carrying 450 amps of current in a 127 mm (5 in.) conduit.

Rearranging:	$x^2 = \frac{I \times S}{20}$ $x = \sqrt{\frac{I \times S}{20}}$
--------------	--

where:	
x	Minimum distance (in meters) from the feeder lines to isocenter of the magnet
I	Maximum allowable RMS single phase current (in amps) or maximum allowable RMS line current (in amps) in three phase feeder lines
S	Separation (in meters) between single phase conductors or greatest separation between three phase conductors

The separation **S** is the spacing between the conductors, and when all 3 conductors are run in a single conduit, **S** is simply the diameter of the conduit.

$$S = 5 \text{ inches} = 0.127 \text{ meters}$$

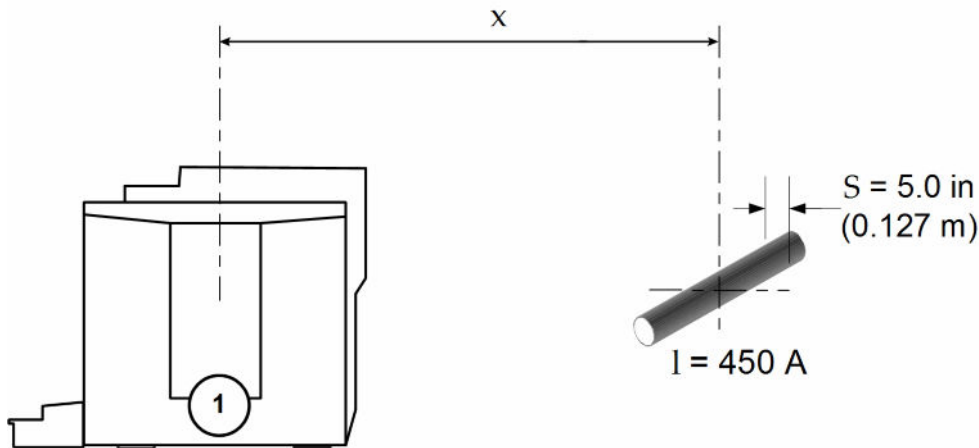

Item	Description
1	Magnet

$$x = \sqrt{\frac{450 \text{ A} \times 0.127 \text{ m}}{20}}$$

The conduit should be 1.7 m (5.6 ft.) from the magnet isocenter.

In other situations, the spacing **S** may be the spacing between HV feeders, the distance between transformer lugs, or the spacing between conduits when the phase conductors are run in separate conduits.

What if it is too close?

If this is an existing condition, you should request an *EMI study* to quantify the magnitude and direction of the AC disturbances. The calculation is worst-case and does not take into account the vector direction of the AC interference. The magnet is only sensitive to AC disturbances that are directed horizontally (magnet z-axis). Also, the calculation does not account for any magnetic shielding effect of steel conduit.

8.4 Selecting Anchor Size



The following is an example to illustrate the selection of correct anchors to install a magnet in a building with 13.8 MPa (2000 psi) concrete. For this example the area is not under seismic requirements.

1. Determine the magnet clamping force (for the Magnet: 11100 N + 900 N = 12000 N (2500 lb. + 200 lb. = 2700 lb.)).
2. Refer to the examples of anchor vendor catalogs below to select the anchor diameter and embedment that meets the clamping force (tension) determined in Step 1.

Diameter : ≥ 15.875 mm (0.625 in.) ≤ 31.75 mm (1.25 in.)

For 203 mm (8 in.) embedment select 19 mm (0.75 in.) diameter

For 114.3 mm (4.5 in.) embedment select 25.4 mm (1 in.) diameter

or

Diameter : Min. M16 Max. M32

For 130 mm embedment select M20 diameter

For 114 mm embedment select M24 diameter

3. The vendor instructions and torque to the maximum recommended level for the anchor selected in Step 2 must be provided to the RF shielded room vendor for correct installation of the anchor and equipment.

Table 8-2 Allowable Anchor Loads in Concrete (English Units)

Anchor Diameter mm (in.)	Embedment Depth mm (in.)	13.8 MPa (2000 psi)		20.7 MPa (3000 psi)		27.6 MPa (4000 psi)		41.4 MPa (6000 psi)	
		Tension kN (lb.)	Shear kN (lb.)	Tension kN (lb.)	Shear kN (lb.)	Tension kN (lb.)	Shear kN (lb.)	Tension kN (lb.)	Shear kN (lb.)
15.9 (5/8)	70 (2 3/4)	5.6 (1250)	12.5 (2800)	7.1 (1600)	13.7 (3070)	8.1 (1810)	14.8 (3300)	8.5 (1920)	12.5 (3330)
	102 (4)	8.3 (1870)	14.8 (3330)	10.7 (2400)	14.8 (3330)	13.0 (2930)	14.8 (3330)	14.2 (3200)	12.5 (3330)
	178 (7)	11.2 (2500)	14.8 (3330)	13.4 (3010)	14.8 (3330)	16.2 (3650)	14.8 (3330)	16.2 (3650)	12.5 (3330)
19.1 (3/4)	83 (3 1/4)	6.9 (1550)	12.8 (2880)	8.7 (1950)	14.7 (3310)	10.5 (2350)	16.6 (3730)	11.6 (2610)	21.4 (4800)
	121 (4 3/4)	11.2 (2510)	20.1 (4510)	14.5 (3250)	20.7 (4650)	17.2 (3870)	21.4 (4800)	20.8 (4670)	21.4 (4800)
	203 (8)	13.0 (2930)	21.4 (4800)	17.2 (3870)	21.4 (4800)	20.2 (4530)	21.4 (4800)	22.8 (5120)	21.4 (4800)

Table 8-2 Allowable Anchor Loads in Concrete (English Units) (Table continued)

Anchor Diameter mm (in.)	Embedment Depth mm (in.)	13.8 MPa (2000 psi)		20.7 MPa (3000 psi)		27.6 MPa (4000 psi)		41.4 MPa (6000 psi)	
		Tension kN (lb.)	Shear kN (lb.)	Tension kN (lb.)	Shear kN (lb.)	Tension kN (lb.)	Shear kN (lb.)	Tension kN (lb.)	Shear kN (lb.)
25.4 (1)	114 (4 1/2)	13.9 (3120)	27.0 (6080)	17.2 (3870)	30.1 (6770)	20.5 (4610)	33.2 (7470)	21.4 (4800)	33.2 (7470)
	152 (6)	19.6 (4400)	33.2 (7470)	28.5 (6400)	33.2 (7470)	32.0 (7200)	33.2 (7470)	32.6 (7330)	33.2 (7470)
	229 (9)	24.9 (5600)	33.2 (7470)	35.59 (8000)	33.2 (7470)	41.77 (9390)	33.2 (7470)	41.8 (9390)	33.2 (7470)



NOTE  All bolded values in this table fail to meet the clamping force (tension), and are therefore not acceptable anchors.

Table 8-3 Allowable Anchor Loads in Concrete (Metric Units)

Anchor Diameter	Embedment Depth mm (in.)	13.8 MPa (2000 psi)		20.7 MPa (3000 psi)		27.6 MPa (4000 psi)		41.4 MPa (6000 psi)	
		Tension kN (lb.)	Shear kN (lb.)	Tension kN (lb.)	Shear kN (lb.)	Tension kN (lb.)	Shear kN (lb.)	Tension kN (lb.)	Shear kN (lb.)
M16	105 (4 1/8)	11.2 (2500)	25.1 (5650)	20.9 (4705)	39.9 (8965)	24.2 (5450)	45.0 (10125)	30.7 (6900)	46.9 (10550)
M20	130 (5 1/8)	25.1 (5650)	52.9 (11900)	30.7 (6910)	58.7 (13195)	36.4 (8175)	64.5 (14490)	44.5 (10005)	64.5 (14490)
M24	155 (6 1/8)	30.0 (6735)	61.2 (13760)	36.9 (8300)	70.5 (15855)	43.9 (9860)	29.8 (6700)	57.7 (12980)	95.6 (21490)

NOTE  All bolded values in this table fail to meet the clamping force (tension), and are therefore not acceptable anchors.

8.5 Sample control schematic for customer-supplied MDP



This section provides an example of a control schematic for the auto-restart and Emergency Power Off (EPO) functions that meets the minimum GE HealthCare PIM requirements. This schematic does not include control, protection, wiring or devices that may be required due to local safety and regulatory requirements. Only the minimum equipment, devices and wiring is shown to meet the performance requirements of GE HealthCare equipment. The final MDP design must be compliant with applicable local codes and regulations.

Figure 8-5 Customer MDP control schematic

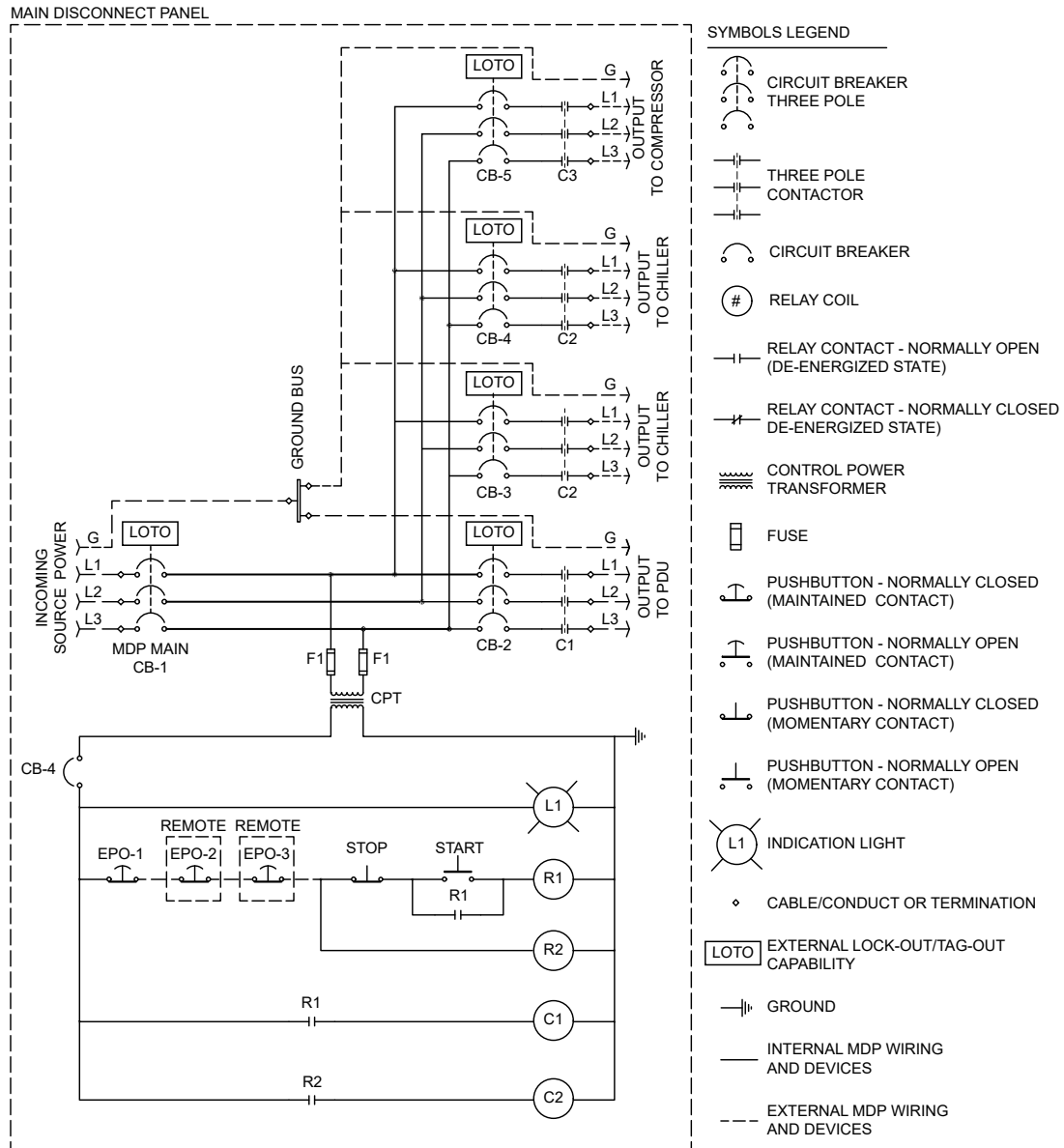

Revision History

Revision	Date	Description
Controlled document for English is posted as DOC1550163.		
1	October 13, 2014	Initial Release.
2	November 18, 2014	Update Patient Table Weight.
3	June 17, 2015	<p>Update the temperature for GOC. Refer to Product Storage and Handling Requirements.</p> <p>Add the bottom view of System Cabinet. Refer to Chapter 4, System Cabinet.</p> <p>Optimize illustration for the magnet geometric center. Refer to SV VibroAcoustic Kit.</p> <p>Add Table for the Required Current for each system configuration. Update Tables for System With BRM Coil Peak Power Demand. Refer to Critical Power Requirements.</p> <p>Update Main Disconnect Panel (MDP) Requirements, see Chapter 2, Main Disconnect Panel (MDP) Requirements</p>
4	August 14, 2015	<p>Add upgrade requirement.</p> <p>Update Usable Cable Lengths. Refer to Chapter 6, MR System Interconnects Specifications.</p>
5	March 29, 2016	<p>Update the transportation and storage environment. Refer to Product Storage and Handling Requirements.</p> <p>Add another kind of the air flow of System Cabinet. Refer to System Cabinet Special Consideration.</p> <p>Add the dimensions for GOC with Dell host PC. Refer to Chapter 5, Operator Workspace.</p> <p>Add the combined vent for Cryogenic Venting. Refer to Cryogenic Venting.</p> <p>Add the equivalent quation between Mpa, Bar, PSI. Refer to Chapter 2, Requirements for Type E.</p> <p>Add the pressure drop table for LCS 4Kw and 8 Kw. Refer to Chapter 2, Requirements For Site Provided Facility Chilled Water or Local Chiller for Type B (B') Configuration.</p> <p>Add the notice that: The System Cabinet should be installed on concrete slab. And update the water hose routing. Refer to System Cabinet Special Consideration.</p> <p>Add the side view of SC with mesh shielded installed. Refer to Chapter 4, Mesh Shield and System Cabinet Cover.</p> <p>Add the dimensions for Step Down Transformer. Refer to Chapter 4, Step Down Transformer.</p> <p>Update the contact information for the finished ceiling. Refer to Finished Room Requirements.</p> <p>Update the test frequency for RF shielding. Refer to RF Shielded Room Requirements.</p> <p>Update the Chapter 3, Acoustic Room Specifications.</p> <p>Remove the description about the UPS from facility option. Refer to Basic System.</p>

Revision	Date	Description
Controlled document for English is posted as DOC1550163.		
6	September 20, 2016	<p>Add the Chapter 2, IEC EMC Compliance.</p> <p>Remove the section System Cabinet Special Consideration, and add necessary information for System Cabinet seismic in Chapter 4, System Cabinet.</p> <p>Change the whole section Cyrogenic Venting to Chapter 3, Magnet Room Venting Requirement.</p> <p>Combine three section Fringe Field, MR Suite Magnetic Field Specifications, and Interference from Changing Magnetic Fields into Chapter 2, MR Suite Magnetic Field Specifications.</p> <p>Add the procedure of finding Chapter 7, Dock Anchor Hole with Magnet Protection Plate in appendix.</p> <p>Add the figure showing the RF shielded Room Ground Isolation Resistance Measurement Method in RF Shielded Enclosure Test Guidelines</p>
7	March 21st, 2017	<p>Remove sections Customer Responsibility, DC Lighting Controller, System Cable Requirements, Communications Requirements, Air Quality.</p> <p>Add section Symbols Key, so, in some later figures, remove the explanations for symbols.</p> <p>Add MR Suite Acoustic Specifications for Equipment Room and Control Room.</p> <p>Combine 'Relative Humidity and Temperature', 'Altitude' and 'Heat Output' into MR Suite Temperature and Humidity.</p> <p>Combine 'System Power Introduction' and 'Critical Power Requirements' into MR Suite Electrical Requirements. Update the requirement for grounding resistance from 10 ohm to meet local code.</p> <p>Correct the data for SC back cover as it is adjustable from 150~250 mm.</p> <p>Clear the requirements for Finished Room Requirements. Especially for Vibroacoustic Mat.</p> <p>Add cable diameter, bend radius, certification, voltage, temperature etc. in MR System Cable Specifications.</p> <p>Correct the minimum service area dimensions in MR Suite Minimum Room Size Requirements.</p> <p>For other sections, optimize the structure, wording, tables, figures to make it fit for single-source intention. No site planning requirement was changed. This version is mainly for launching a new publication tool.</p>
8	June 14th, 2018	<p>Correct max flow and min flow value in table Facility Chilled Water or Local Chiller Requirement</p> <p>Correct current value in table Required Current per Input voltage setting</p> <p>Update below figures, make them more clear for understanding. Figure 2-10 Magnetic Fringe Field Side View, Figure 2-11 Magnetic Fringe Field Top, Figure 2-12 Magnetic Fringe Field Front View, Figure 2-18 Equipment Room System Cabinet Separations (Top View), Figure 4-9 Cryocooler Compressor CSA-71A for 200V Site Only (Air Cooled)</p> <p>Correct the cover adjustable range from 100-200mm to 150-250mm: Figure 4-4 Mesh Shield and System Cabinet Cover, Figure 4.3 Mesh Shield and System Cabinet Cover</p>

Revision	Date	Description
Controlled document for English is posted as DOC1550163.		
9	April 17th, 2019	<p>Revised IEC EMC Compliance section; added Table 4: Guidance And Manufacturer's Declaration Electromagnetic Proximity field Immunity.</p> <p>Add the 90° Magnet vent adaptor information, see Figure 4.</p> <p>Update the finished ceiling height to 2.5m, see Table 2-1 System Minimum Room Inside Clear Space Dimensions.</p> <p>Update the notes for add M7000GM for LCC-W magnet, see Figure 2-9 Minimum Magnet Ceiling Height (Top View).</p> <p>Correct the Figure for showing the accurate, see Figure 2-18 Equipment Room System Cabinet Separations (Top View).</p> <p>Update Figure for add propylene glycol, see Figure 2-30 Cooling Water Typical Flow Characteristics.</p> <p>Add magnet dimension for LCC-W, see 2.10.3 MR System Component Shipping Specifications.</p> <p>Update notes for providing accurate description of extension cable, see Table 6-2 Available Cable Lengths.</p> <p>Update cart width dimension to 35.00 mm, see Figure 2-38 Gradient Coil Cart.</p> <p>Correct the rebar-free area for table anchor is 4 inch in note and add figure link, see Figure 3-10 Magnet Mounting Detail.</p> <p>Remove the shim lead info from the magnet enclosure dimensions figure.</p> <p>Add allowed tilting angle requirement for system cabinet, see 4.2 System Cabinet.</p> <p>Remove magnet anchors requirement: " Magnet anchors must be installed before the magnet is delivered."</p>
10	July 5th, 2019	<p>Revised IEC EMC Compliance section; update Table 4</p> <p>Correct the Figure for showing the accurate, see Figure 2-18 Equipment Room System Cabinet Separations (Top View).</p> <p>Remove the description "If rear wall magnetic shield or steel RF wall is closer than 2500mm from isocenter, it should be verified by GEHC PMI." on Magnetic shielded room requirements</p>
11	February 19th, 2020	<p>Chapter 2.11 MR Suite Electrical Requirements</p> <p>Update the contents for phase in M50022MA</p> <p>Chapter 4.4 Main Disconnect Panel (MDP) Specifications</p> <p>Add M50022MA comparasion.</p> <p>Chapter 5.1 Operator Workspace Equipment Specifications</p> <p>Add T5820 GOC dimension and weight information</p> <p>Chapter 3.5.6 System Cabinet and Penetration Panel Wall Opening Requirements</p> <p>Optimized all the pics.</p>
12	July 1st, 2020	<p>Update the antifreeze and related information for local chiller requirement.</p> <p>Update the voltage for MDP M50022MA.</p> <p>Update the compressor info to F50SH.</p> <p>Add MM4 info and keep MM3.</p> <p>Change the System Cabinet height measurement method and data.</p> <p>Single-source the electrical requirement and MDP specification.</p>

Revision	Date	Description
Controlled document for English is posted as DOC1550163.		
13	June 20th, 2021	<p>Major content re-organization throughout the manual, and some content was moved to separate documents. See the Related Documents section in this manual for document numbers.</p> <p>New personnel matrix and icons added throughout the manual to help contractors and customers locate the content they need for their respective project work.</p> <p>Removed list of system cable specifications from the PIM.</p> <p>Grounding requirements related to RF shielding moved to a separate document.</p> <p>IEC requirements moved to a separate document</p> <p>Acoustic requirements moved to a separate document</p> <p>Magnet Room venting requirements moved to a separate document</p> <p>RF shielded room requirements moved to a separate document</p>
14	Jan. 2023	<ul style="list-style-type: none"> • Section 1.1.4: Table 1-2: Updated manual numbers • Section 2.2.6: Updated Figure 2-5 System with equipment room (Type D) • Section 2.3, Step 1 after table 2-1: Updated sentence for clarity • Section 2.3, Added recommend minimum service area • Section 2.7.2, Step 1: Added additional products • Section 2.10.2: removed Main Disconnect Panel (MDP) M3088TM and M50022MA and added M50022MB and M50022MC content • Section 2.10.3: Added note to explain exempt countries • Section 2.10.4: Removed CSA-71, added FA-50SH and FA-50SL • Section 2.11.3: Removed SPT Phantom Set • Section 3.5.7: added Storage Cabinets content • Section 4.2.2 Added sentence that only exempt countries can supply their own MDP; removed Main Disconnect Panel (MDP) M3088TM and M50022MA and added M50022MB and M50022MC content • Section 5.1.3 Changed anchor size from 9.5mm to M10 and Updated Figure 5-3 Global Operator Cabinet (GOC) Item Description • Section 5.1.4 Changed weight from 11.8 kg to 6.7 kg • Section 7.1.2: Updated Figure 7-5 Available Cable/Hose Lengths for Type D • Section 8.1 : Removed definitions "Exclusion Zone", "Gradient" and "Security Zone"

Revision	Date	Description
Controlled document for English is posted as DOC1550163.		
15	Jul. 2024	<ul style="list-style-type: none"> • Table 2-1, Table 2-2: Updated the dimensions which accurate to one decimal place, corrected equipment room area • Figure 2-8: Updated dimensions and callout 1 description • Figure2-10, Figure 2-11, Figure 2-17: Removed text and added callouts on image • Table 2-17: Corrected the values for PDU • Figure 2-30, Figure 2-31, Figure 2-32, Figure 2-33, Figure 2-34, Figure 2-35, Figure 2-36, Figure 2-37, Figure 2-38, Figure 2-39: Simplified component name and updated the callouts for Figure 2-30 • Table 2-19, Table 2-21: Updated callouts align with Figure • Table 2-23: Updated weight for ISC • Table 2-24: Updated weight for ISC • Table 2-25: Added GCU and CCU FRU shipping specification • Figure 2-41, Figure 3-2, Figure 3-3, Figure 3-4, Figure 3-6, Figure 3-7, Figure 3-9, Figure 3-11, Figure 3-15, Figure 3-16, Figure 3-17, Figure 3-19, Figure 3-21, Figure 3-22, Figure 3-23: Updated image make it more clear • Figure 3-20: Updated dimensions • Figure 4-1, Figure 4-2, Figure 4-3: Updated SC dimensions • Section 4.3: Updated weight • Figure 4-5: Updated CoG dimensions • Figure 4-8: Added callout 6 • Figure 4-12, Figure 4-13, Figure 4-14, Figure 4-15, Figure 4-16, Figure 4-17, Figure 4-18, Figure 4-19, Figure 4-21, Figure 4-22, Figure 4-23, Figure 5-1, Figure 5-7: Updated image make it more clear • Section 5.1.3 Added weight for HPZ4G5 • Figure 5-3: Added callouts and callout table • Figure 5-5: Updated dimension of width • Table 7-3, Table 7-4: All updated • Figure 7-1, Figure 7-2, Figure 7-3, Figure 7-4, Figure 7-5: Updated align with Table 7-3 and Table 7-4 • Table 7-5: Corrected type error • Table 7-6: All updated



GE HealthCare

www.gehealthcare.com